



FLOOR GRINDERS
INDUSTRIAL VACUUMS
DIAMOND TOOLS

*Equipments and products
for any kind of floor*

Klinsystem is the benchmark in the sector of professional floor grinding and polishing machines



Total flooring solution

Equipments and products are internationally recognized as the best on the market and used in the most prestigious job sites, thanks to the excellent quality of the materials, Klinsystem equipments are used all over the world.

Klinsystem has always had a particular attention to new markets, all products are designed to satisfy the market demands for the *"total flooring solution"* to meet all the client needs. The knowledge acquired over the years allowed Klinsystem to develop an innovative system that uses a new generation of grinding and polishing machines equipped with a counter-rotating planetary system. All equipments are characterized by high quality and technology, always positioned in higher level of the market, this allowed Klinsystem to acquire in a short time a relevant position in the National and International market.

During last years, Klinsystem introduced many technological innovations, based on efficient and versatile tools and equipments to offer to its clients economic advantage and rapid return on investment. The company never stops researching and improving its products, investing in research and development, in order to always give its customers products and solutions top of the range.

Klinsystem has been always focused in sectors such as stone care, industrial floor treatment, floor maintenance, wooden floor care and Surface Preparation. Klinsystem is today one of the most innovative international companies which works in the concrete and natural stone care field, with branch offices and dealers all around the world.

Klinsystem



The Evolution of Grinding

**Best prospects
for your business**

Latest technologies

Prompt assistance

Discover all the information about Klinsystem and the advantages of working with the most advanced technologies made available by our company.

www.klinsystem.com



LB 38GR REMOTE CONTROL



LB 38GR REMOTE CONTROL

ELITE
S E R I E S



WORKING WIDTH \varnothing 950mm

Dust-Proof grinding head with low-friction chain gear planetary drive.



INTUITIVE TOUCHSCREEN PANEL / HMI

New HMI provides essential operating information and implements operators' instructions.

- Indications of power supply and power consumption
- Machine load and hours worked
- Tool holder rpm and option to choose rpm setting with tool input
- Water supply and lights activation
- Maintenance reminders



NEW INTELLIGENT REMOTE CONTROL

Precise control over the machine two sensitive thumbsticks control its position and offset, including integrated mapping on the offset. A wide range of functions. Super light and easy to use with ergonomic rubber grip. RC Battery (rechargeable) AA 1,2V

Integrated weight system



Heavy-duty
THIRD WHEEL

L38GRE three heads planetary floor grinder working section 950mm fitted with Kawasaki FX1000V 999cc propane motor 26 Kw 35 Hp with **new intelligent remote control**. Total weigh of machine 719 Kg.

Combines the convenience of a remote control with the flexibility of a powerful propane engine and ease of use of a planetary grinder to offer one of the highest grinder productivity rates in the industry. Ideal for large commercial projects, where power may not be available.

Improved dust collection: adjustable skirt with a flexible brush for better dust containment. The vacuum hose connection is closer to the dust source and utilizes a metal camlock attachment. Convenient **integrated lift points** for moving the machine with a forklift.

2 Led Lights in front and 1 back of machine for monitoring the floor. **Charging phone station** with dual USB port.

Durable **stainless steel cup holder**. **New handle bar** with multiple handle positions. Propane tank capacity 15Kg.

L38GR PRODUCTIVITY RATES* - Sqm/H

Grinding and Polishing Concrete 7 Step	40 - 45
Floor Preparation 1 Step	160 - 220
Polishing Terrazzo 5 Step	45 - 60
Resin, varnish and coating removal 1 Step	200 - 300
Grinding and Polishing Marble 5 Step	30 - 50
Grinding and Polishing Granite 7 Step	20 - 30

*production rates may vary according to the surface conditions, diamond tools used, equipments, operator, etc.

TECHNICAL DATA

Power	26 Kw - 35 Hp	Tool connection	Quick Change
Working Width	950 mm	Tool holder diameter	3 x 330mm/13"
Engine	Kawasaki Propane	Application	Wet / Dry
Weight	719 Kg	Dust-vacuum	Yes
Engine capacity	999 cc	Water Tank capacity	46 Lt
Variable Speed	2000 - 3600 rpm	Code	L38GREB
		Price	€ 43.820,00

L32R REMOTE CONTROL

ELITE
SERIES



L 32R Three heads professional floor grinder fitted with a powerful 15 Kw - 20 Hp Siemens motor equipped with **New Remote Control System**. Suitable for grinding and polishing Concrete and Natural Stone surfaces on large areas.

Thanks to the forced counter rotating planetary system (820mm) provide a considerable saving of labor and work time. Equipped with **4-position weight adjustment system** to allows to balance the weight of the machine forward or backward to increase or decrease the working pressure. It also facilitates the transport and tilting of the machine for tool change. Wide pneumatic wheels allow easy maneuverability on the work area, good grip and no marks on the floor.

The machine is **equipped with a special battery system** which allows you to move the machine without problems on site without connecting the electric cable. This also simplifies the loading and unloading operations.

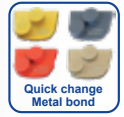

WORKING WIDTH \varnothing 850mm



INTUITIVE TOUCHSCREEN PANEL / HMI

New HMI provides essential operating information and implements operators' instructions.

- Indications of power supply and power consumption
- Machine load and hours worked
- Tool holder rpm and option to choose rpm setting with tool input
- Water supply and lights activation
- Maintenance reminders



NEW INTELLIGENT REMOTE CONTROL

Precise control over the machine two sensitive thumbsticks control its position and offset, including integrated mapping on the offset. A wide range of functions. Super light and easy to use with ergonomic rubber grip. **RC Battery (rechargeable) AA 1,2V**

L32R PRODUCTIVITY RATES* - Sqm/H

Grinding and Polishing Concrete 7 Step	25 - 30
Floor Preparation 1 Step	100 - 130
Polishing Terrazzo 5 Step	30 - 40
Resin, varnish and coating removal 1 Step	100 - 150
Grinding and Polishing Marble 5 Step	20 - 30
Grinding and Polishing Granite 7 Step	10 - 15

*production rates may vary according to the surface conditions, diamond tools used, equipments, operator, etc.

TECHNICAL DATA

Power	15 Kw - 20 Hp	Tool connection	Quick Change
Working Width	850 mm	Tool holder diameter	3 x 330 mm / 13"
Voltage	380 - 400 V - 50 Hz	Application	Wet / Dry
Weight	710 Kg	Dust-vacuum	Yes
Amperage	Max 32 Amp	Water Tank capacity	46 Lt
Variable Speed	300 - 1300 rpm	Code	L3213REUB
		Price	€ 36.350,00

L32 R REMOTE CONTROL



NEW 3RD WHEEL AND LARGER TIRES

L32 20Hp

ELITE
SERIES

Integrated weight system



L 32 Three heads planetary floor grinding and polishing machine. Fitted with 15 Kw - 20 Hp - 400 V motor. The most performing machine of this segment.

Suitable for grinding and polishing marble, terrazzo, granite and concrete floors. Also ideal for floor preparation, bush-hammering and coatings removal. Equipped with **4-position weight adjustment system** to allow to balance the weight of the machine forward or backward to increase or decrease the working pressure.

New 3rd wheel included with the machine.

Very powerful and heavy machine for working on large areas, with total weight of more than 685 kg. Good choice for professionals.

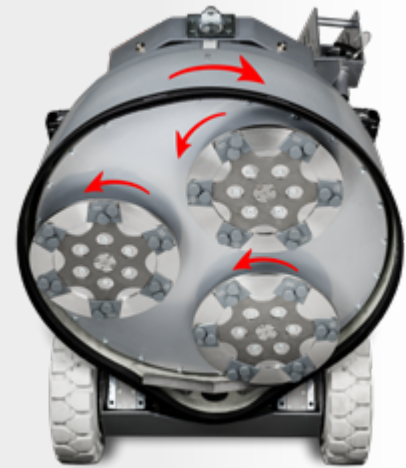

WORKING WIDTH \varnothing 850mm



CHARGING PHONE STATION WITH DUAL USB 2.0 PORT

3.15 Amps for faster charging with a shutoff when charge is complete and new durable stainless steel cup holder.



TWO LED LIGHTS FOR MONITORING THE FLOOR

A detachable LED light (with a magnet) improves visibility, and a second LED light attached in the back of the machine near the floor helps monitor the scratch pattern.

L32 PRODUCTIVITY RATES* - Sqm/H

Grinding and Polishing Concrete 7 Step	25 - 30
Floor Preparation 1 Step	100 - 130
Polishing Terrazzo 5 Step	30 - 40
Resin, varnish and coating removal 1 Step	100 - 150
Grinding and Polishing Marble 5 Step	20 - 30
Grinding and Polishing Granite 7 Step	10 - 15

*production rates may vary according to the surface conditions, diamond tools used, equipments, operator, etc.

TECHNICAL DATA

Power	15 Kw - 20Hp	Tool connection	Quick Change
Working Width	850 mm	Tool holder diameter	3 x 330 mm / 13"
Voltage	380 - 400 V - 50 Hz	Application	Wet / Dry
Weight	685 Kg	Dust-vacuum	Yes
Amperage	Max 32 Amp	Water Tank capacity	46 Lt
Variable Speed	300 - 1300 rpm	Code	L3213EUB
		Price	€ 23.820,00

L 30L 15Hp

ELITE SERIES



WORKING WIDTH Ø 770mm



EASY TO USE INTEGRATED WEIGHTS

Equipped with 4-position weight adjustment system to allows to balance the weight of the machine forward or backward to increase or decrease the working pressure.



NEW ADJUSTABLE HANDLE BAR

Multiple handle positions for more convenient operation and transportation. Make sure the handle position is locked when moving or using the machine.



Integrated weight system

Low-Profile Base

L 30L Three heads planetary floor grinding machine fitted with 11 Kw - 15 Hp - 400 V motor. With 770mm working section is the most versatile and selling machine. Auto levelling planetary system. Heavy machine with total weight of more than 390 kg.

The machine has low flange that allows for grinding and polishing under racks at 1- 4 cm. Such solution applied for its casing makes it possible to avoid manual processing during works in market stores and warehouses.

Equipped with **4-position weight adjustment system** to allows to balance the weight of the machine forward or backward to increase or decrease the working pressure.

L30L PRODUCTIVITY RATES* - Sqm/H

Grinding and Polishing Concrete 7 Step	25 - 30
Floor Preparation 1 Step	100 - 130
Polishing Terrazzo 5 Step	30 - 40
Resin, varnish and coating removal 1 Step	100 - 150
Grinding and Polishing Marble 5 Step	20 - 30
Grinding and Polishing Granite 7 Step	9 - 12

*production rates may vary according to the surface conditions, diamond tools used, equipments, operator, etc.

TECHNICAL DATA

Power	11 Kw - 15 Hp	Tool connection	Quick Change
Working Width	770 mm	Tool holder diameter	3 x 330 mm / 13"
Voltage	380 - 400 V - 50 Hz	Application	Wet / Dry
Weight	390 Kg	Dust-vacuum	Yes
Amperage	Max 30 Amp	Water Tank capacity	20 Lt
Variable Speed	300 - 1300 rpm	Code	L30LEUB

Price € 19.790,00

L25 R REMOTE CONTROL



L 25R REMOTE CONTROL**ELITE**
SERIES**WORKING WIDTH Ø 660mm****INTUITIVE TOUCHSCREEN PANEL / HMI**

New HMI provides essential operating information and implements operators' instructions.

- Indications of power supply and power consumption
- Machine load and hours worked
- Tool holder rpm and option to choose rpm setting with tool input
- Water supply and lights activation
- Maintenance reminders

**NEW INTELLIGENT REMOTE CONTROL**

Precise control over the machine two sensitive thumbsticks control its position and offset, including integrated mapping on the offset. A wide range of functions. Super light and easy to use with ergonomic rubber grip.

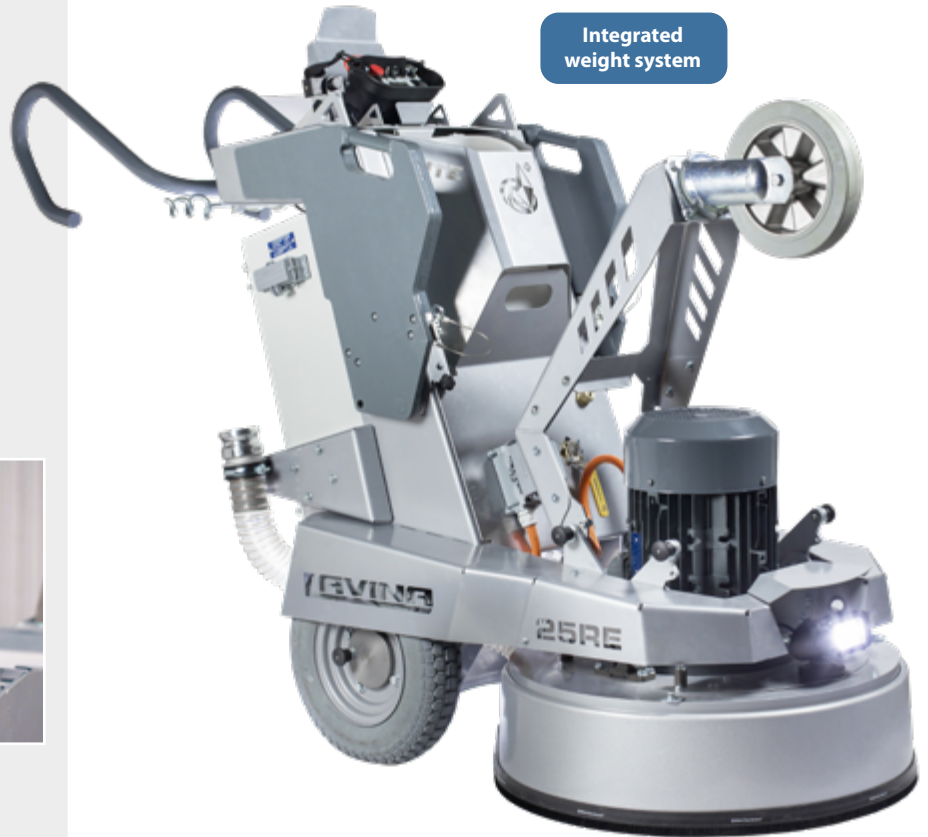
**Integrated weight system**

L 25R Three heads planetary floor grinder fitted with 7,5 Kw 10 Hp motor with new intelligent remote control. Total weight of machine 557 kg.

Suitable for grinding and polishing marble, terrazzo, granite and concrete floors. Also ideal for floor preparation, bush-hammering and coatings removal. Machine speed and its rotational speed can be adjusted quickly and easily using the control panel. Very good choice for professionals working on large areas.

Single person is able to operate with the vacuum and the grinder problem-free. Equipped with **4-position weight adjustment system** to allows to balance the weight of the machine forward or backward to increase or decrease the working pressure.

L25R PRODUCTIVITY RATES* - Sqm/H

Grinding and Polishing Concrete 7 Step	20 - 25
Floor Preparation 1 Step	50 - 100
Polishing Terrazzo 5 Step	20 - 30
Resin, varnish and coating removal 1 Step	80 - 120
Grinding and Polishing Marble 5 Step	12 - 25
Grinding and Polishing Granite 7 Step	8 - 10

*production rates may vary according to the surface conditions, diamond tools used, equipments, operator, etc.

TECHNICAL DATA

Power	7,5 Kw - 10 Hp	Tool connection	Quick Change
Working Width	660 mm	Tool holder diameter	3 x 235 mm / 9"
Voltage	380 - 400 V - 50 Hz	Application	Wet / Dry
Weight	557 Kg	Dust-vacuum	Yes
Amperage	Max 15 Amp	Water Tank capacity	20 Lt
Variable Speed	300 - 1300 rpm	Code	L25REUB
Price		€ 29.280,00	

L 25L 15Hp

ELITE
SERIES



Integrated weight system



WORKING WIDTH \varnothing 660mm



NEW PLANETARY SYSTEM

New chain driven forced planetary system, designed to provide more durable rotation and reduce the maintenance, resulting in **higher efficiency and productivity**. Completely redesigned frame delivers **superior maneuverability and easy tool changes**.

Dust-proof grinding head with low-friction chain gear planetary drive protects internal components from dust and moisture, which **reduces maintenance and increases service life**.

The chain has been upgraded on 20"/25"/30" models.

L 25L Three heads planetary grinding and polishing machine with 11 Kw - 15 Hp motor, designed for use in larger projects. For concrete, marble and granite grinding and polishing, coatings removal and floor preparation.

Heavy and efficient, simple to use and easy to transport. Equipped with **4-position weight adjustment system** to allows to balance the weight of the machine forward or backward to increase or decrease the working pressure.

Two led lights for monitoring the floor: a detachable LED light (with a magnet) improves visibility, and a second LED light attached in the back of the machine near the floor helps monitor the scratch pattern.

L 25L PRODUCTIVITY RATES* - Sqm/H

Grinding and Polishing Concrete 7 Step	20 - 25
Floor Preparation 1 Step	50 - 100
Polishing Terrazzo 5 Step	20 - 30
Resin, varnish and coating removal 1 Step	80 - 120
Grinding and Polishing Marble 5 Step	12 - 25
Grinding and Polishing Granite 7 Step	8 - 10

*production rates may vary according to the surface conditions, diamond tools used, equipments, operator, etc.

TECHNICAL DATA

Power	11 Kw - 15 Hp	Tool connection	Quick Change
Working Width	660 mm	Tool holder diameter	3 x 235 mm / 9"
Voltage	380 - 400 V - 50 Hz	Application	Wet / Dry
Weight	355 Kg	Dust-vacuum	Yes
Amperage	Max 30 Amp	Water Tank capacity	20 Lt
Variable Speed	300 - 1300 rpm	Code	L25LEUB
		Price	€ 18.380,00

L 25 10Hp

ELITE
SERIES

CHARGING PHONE STATION WITH DUAL USB 2.0 PORT
3.15 Amps for faster charging with a shutoff when charge is complete and new durable stainless steel cup holder.



INTEGRATED LIFT POINTS
New lift points design facilitates moving the machine with a forklift.

EASY TO USE INTEGRATED WEIGHTS
Equipped with 4-position weight adjustment system to allows to balance the weight of the machine forward or backward to increase or decrease the working pressure.

Integrated
weight system

L 25 Three heads planetary machine for grinding and polishing. Fitted with 7,5 Kw - 10 Hp motor. Ideal for grinding and polishing marble, terrazzo, granite and concrete floors.

Also suitable for floor preparation, bush-hammering and coatings removal. Powerful machine with total weight of more than 345 kg. Good choice for professionals, perfect for areas up to 1.000 m².

Equipped with **4-position weight adjustment system** to allows to balance the weight of the machine forward or backward to increase or decrease the working pressure.

Two led lights for monitoring the floor: a detachable LED light (with a magnet) improves visibility, and a second LED light attached in the back of the machine near the floor helps monitor the scratch pattern.

L25 PRODUCTIVITY RATES* - Sqm/H

Grinding and Polishing Concrete 7 Step	20 - 25
Floor Preparation 1 Step	50 - 100
Polishing Terrazzo 5 Step	20 - 30
Resin, varnish and coating removal 1 Step	80 - 120
Grinding and Polishing Marble 5 Step	12 - 25
Grinding and Polishing Granite 7 Step	8 - 10

*production rates may vary according to the surface conditions, diamond tools used, equipments, operator, etc.

TECHNICAL DATA

Power	7,5 Kw - 10 Hp	Tool connection	Quick Change
Working Width	660 mm	Tool holder diameter	3 x 235 mm / 9"
Voltage	380 - 400 V - 50 Hz	Application	Wet / Dry
Weight	345 Kg	Dust-vacuum	Yes
Amperage	Max 15 Amp	Water Tank capacity	20 Lt
Variable Speed	300 - 1300 rpm	Code	L25EUB
		Price	€ 16.750,00

L 20N 7.5Hp

ELITE
S E R I E S

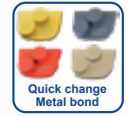

NEW PLANETARY SYSTEM

New chain driven forced planetary system, designed to provide more durable rotation and reduce the maintenance, resulting in higher efficiency and productivity. Completely redesigned frame delivers **superior maneuverability and easy tool changes**. **Dust-proof grinding head with low-friction chain gear planetary** drive protects internal components from dust and moisture, which **reduces maintenance and increases service life**. The chain has been upgraded on 20"/25"/30" models.

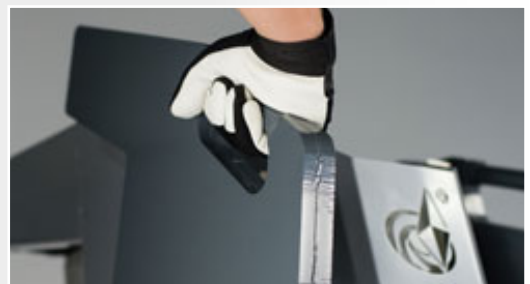

INTEGRATED WEIGHTS SYSTEM

Equipped with 4-position weight adjustment system to allows to balance the weight of the machine forward or backward to increase or decrease the working pressure.

L 20N Three heads planetary grinder suitable for grinding and polishing. Fitted with **7,5 Hp 380 V motor**. Is the most performing machine of this segment.

Ideal for grinding and polishing marble, terrazzo, granite and concrete floors. Also suitable for floor preparation, bush-hammering, old glues and coating/resin removal. **Quick release of planetary head** for easy transport. **New adjustable handle bar** with multiple handle positions for more convenient operation and transportation.

Heavy machine with total weight of more than 265 kg. Good choice for professionals with task to cover a surface of up to 500/800 m².

L 20N PRODUCTIVITY RATES* - Sqm/H

Grinding and Polishing Concrete 7 Step	10 - 15
Floor Preparation 1 Step	40 - 80
Polishing Terrazzo 5 Step	9 - 15
Resin, varnish and coating removal 1 Step	40 - 60
Grinding and Polishing Marble 5 Step	10 - 15
Grinding and Polishing Granite 7 Step	6 - 10

*production rates may vary according to the surface conditions, diamond tools used, equipments, operator, etc.

TECHNICAL DATA

Power	5,5 Kw - 7,5 Hp	Tool connection	Quick Change
Working Width	510 mm	Tool holder diameter	3 x 235 mm / 9"
Voltage	380 V - 50 Hz	Application	Wet / Dry
Weight	265 Kg	Dust-vacuum	Yes
Amperage	Max 15 Amp	Water Tank capacity	20 Lt
Variable Speed	300 - 1300 rpm	Code	L2ONEUB
		Price	€ 10.690,00



NEW ADJUSTABLE HANDLE BAR

Multiple handle positions for more convenient operation and transportation. Make sure the handle position is locked when moving or using the machine.

IMPROVED DUST COLLECTION EFFICIENCY

Adjustable skirt with a flexible brush for better dust containment. Also, the vacuum hose connection is now closer to the dust source, and utilizes a metal camlock attachment.



TWO LED LIGHTS FOR MONITORING THE FLOOR



VARIABLE SPEED
300-1300 rpm

Single Phase
230 V 4 Hp

L 20 Three heads planetary grinder suitable for grinding and polishing marble, terrazzo, granite and concrete floors. The machine can working in both large and narrow areas like bathrooms and kitchens. Powerful **4 Hp motor single-phase with weight of 200 kg**.

Quick release of planetary head for easy transport. The machine is easy to transport, very simple and convenient to use. Completely re-designed frame delivers superior maneuverability and easy tool changes.

Convenient **integrated lift points** for moving the machine with a forklift. This model has attracted many supporters all over the world and is the most popular choice in small-size machine segment.

L20 PRODUCTIVITY RATES* - Sqm/H

Grinding and Polishing Concrete 7 Step	8 - 12
Floor Preparation 1 Step	40 - 60
Polishing Terrazzo 5 Step	10 - 15
Resin, varnish and coating removal 1 Step	40 - 60
Grinding and Polishing Marble 5 Step	8 - 12
Grinding and Polishing Granite 7 Step	3 - 5

*production rates may vary according to the surface conditions, diamond tools used, equipments, operator, etc.

TECHNICAL DATA

Power	3 Kw - 4 Hp	Tool connection	Quick Change
Working Width	510 mm	Tool holder diameter	3 x 235 mm / 9"
Voltage	230 V - 50/60 Hz	Application	Wet / Dry
Weight	200 Kg	Dust-vacuum	Yes
Amperage	Max 14 Amp	Water Tank capacity	20 Lt
Variable Speed	300 - 1300 rpm	Code	L20EUB
Price		€ 8.890,00	

L 16 220V

ELITE
SERIES



VARIABLE SPEED
300-900 rpm

Single Phase
230 V 3 Hp

Quick release of the head
for easy transport

L 16 Three heads planetary grinder suitable for grinding and polishing marble, granite, concrete, wooden floors also suitable for floor preparation, glue and resin removal on small areas. Ideal to work in residential areas. Dust proof grinding head with 3x7" discs and forced planetary drive.

L16 can be used in both small and narrow areas like bathrooms and kitchens. **Powerful 4 Hp motor single-phase** can be loaded with 2 extra weights (2 x 8 Kg OPTIONAL). Cord extension not included.

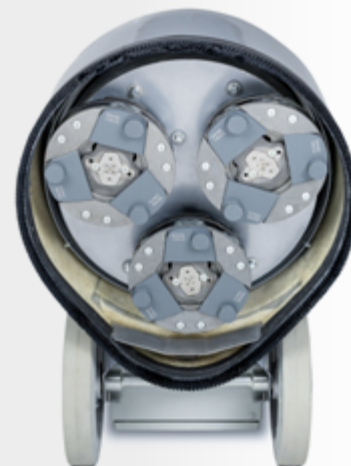

WORKING WIDTH Ø 420mm



FOLDABLE FRAME AND COMPACT DESIGN

L16 is easy to handle and storage, the machine can be divided in two pieces and transported even in a small car. Head 68 kg - Carriage 30 kg. Dustproof grinding head with 3 x 178mm tool holders Forced planetary drive.



L 16 PRODUCTIVITY RATES* - Sqm/H

Grinding and Polishing Concrete 7 Step	5 - 8
Floor Preparation 1 Step	25 - 40
Polishing Terrazzo 5 Step	5 - 8
Resin, varnish and coating removal 1 Step	15 - 30
Grinding and Polishing Marble 5 Step	5 - 8
Grinding and Polishing Granite 7 Step	3 - 5

*production rates may vary according to the surface conditions, diamond tools used, equipments, operator, etc.

TECHNICAL DATA

Power	2,2 Kw - 4 Hp	Tool connection	Quick Change
Working Width	420 mm	Tool holder diameter	3 x 178 mm / 7"
Voltage	230 V - 50/60 Hz	Application	Wet / Dry
Weight	98 Kg	Dust-vacuum	Yes
Amperage	Max 12 Amp		
Variable Speed	300 - 900 rpm	Code	L16EU
		Price	€ 6.450,00

L 14 EDGE GRINDER

ELITE

S E R I E S



WORKING WIDTH \varnothing 335mm

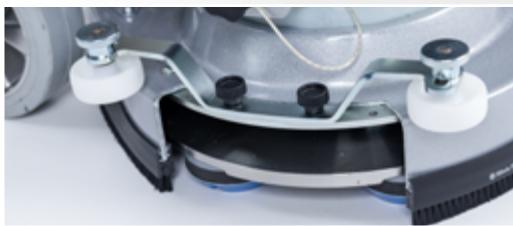

REMOVABLE LATERAL INLET

allows the L14 to be used as edge grinder.



HEAD 35 KG CARRIAGE 25 KG



Adjustable handle bar
to use as edger machine

VARIABLE SPEED
400-1000 rpm

Single Phase
230 V 3 Hp

Quick release of the head
for easy transport

L 14 Powerful and versatile single disc floor grinder suitable for floor grinding and floor preparation, glue and resin removal. Ideal to work in small residential, commercial project and industrial areas. Powerful 4 Hp motor single-phase. Foldable frame and compact design.

L 14 is easy to handle and storage. **The removable lateral inlet allows the L 14 to be used as edge grinder.** The machine can be divided in two pieces and transported even in a small car: Head 35 kg - Carriage 25 kg. Dust-proof grinding head protects internal components from dust and moisture which reduces maintenance and increases service life. Flexible brush for better dust containment. Cord extension not included.

L 14 PRODUCTIVITY RATES* - Sqm/H

Concrete grinding 1 Step	40 - 50
Terrazzo grinding 1 Step	60 - 90
Glue removal 1 Step	30 - 40
Paint removal 1 Step	20 - 40

*production rates may vary according to the surface conditions, diamond tools used, equipments, operator, etc.

TECHNICAL DATA

Power	2,2 Kw - 4 Hp	Tool connection	Quick Change
Working Width	335 mm	Tool holder diameter	1 x 335 mm / 13"
Voltage	230 V - 50/60 Hz	Application	Wet / Dry
Weight	63 Kg	Dust-vacuum	Yes
Amperage	Max 12 Amp	Code	L14EU
Variable Speed	400 - 1000 rpm	Price	€ 4.850,00



Full range of Floor Grinding machines Industrial Vacuums and Diamond tools

Klinsystem is able to offer to your company the best prospects of business, the latest technologies in this field and the assistance for the development of your company. Discover all information about Klinsystem and the advantages of working with the most advanced technologies made available by our company.

PERFORMANCE ABOVE THE REST.

A photograph showing a row of industrial floor grinding machines in a large, well-lit factory or warehouse. The machines are white and grey, with various components like wheels and grinding heads visible. They are arranged in a line, receding into the distance. The floor is highly reflective, showing the machines and the overhead lights. The ceiling has a grid of lights and structural beams.

ELITE
S E R I E S

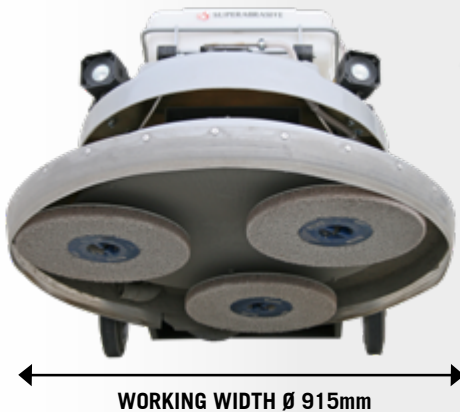
LB 36G PROPANE BURNISHER**ELITE**
SERIES

- Powerful Kawasaki engine
- Forced planetary drive with 3x356mm heads
- Optimal pad pressure + flexible head design
- Superior dust collection



LB 36G PROPANE BURNISHER First in the world three heads high-speed planetary machine. Fitted with Kawasaki 13 Kw propane motor. It can be used in closed rooms thanks to application of catalyst installed on the motor. The machine has an integrated dust container. Planetary system and soft heads enable wide use of various tools for light polishing, honing, polishing and daily cleaning of surfaces. A low-profile base for buffing and polishing under racks.

High productivity of the machine allows works to be carried out much faster than using a standard single head or a heavy duty rotary machine. Very popular model in the U.S. Perfect for keeping large polished concrete areas clean.

LB 36G has no limitations due to cables or lack of electric power. Heavy duty transmission. No performance drop and loss of time caused by the power gridding.

TECHNICAL DATA

Power	13 Kw - 18 Hp	Tool connection	Quick Change
Working Width	915 mm	Tool holder diameter	3 x 356 mm / 14"
Engine	Kawasaki Propane	Application	Wet / Dry
Weight	280 Kg	Dust-vacuum	Yes
Engine capacity	603 cc	Water Tank capacity	20 Lt
Variable Speed	2000 - 3000 rpm	Code	LB36G
		Price	€ 15.550,00

Concrete POLISHING SYSTEM

COATING REMOVAL

Carbide Scrapers for thick glue removal (pag. 22). PCD segmented tools with a metal button or sacrificial bars for coating removal. Recommended speed 550-650 rpm.

GRINDING / FLOOR PREPARATION

- Select the proper Metal bond based on the concrete hardness.
 - Select between single or double button depending on the machine size (*More info pag. 22-24*).
 - Start with grit 30 to expose Large aggregate.
 - Start with grit 70 to expose Medium aggregate.
 - Start with grit 120 for Salt & Pepper.
- Recommended speed 550-650 rpm.

DENSIFIER

Concrete Hardner KS10 Sodium/Potassium Densifier to improve the hardness and quality of new and existing concrete floors (*Instruction pag. 61*).

HONING

Grit 100 Hybrid - HD Copper, Calibra or Corsa (pag. 27). Hybrids tools are ideal as transition step between metals and resins. Continue with grit 200 and grit 400 Hybrid or Resin (pag. 26). Recommended speed 650-750 rpm.

COLORING

Concrete Color Dye (Powder)

Concentrate colour powder to be dilute in 4 liters of Acetone (*Instruction pag. 62*).

POLISHING

Polish with V-HARR resin bond discs grit 800 and grit 1800. Recommended speed 800-1100 rpm.

SEALER

Concrete Guard Lithium

glossy stain protection sealer, oil-repellent. Can be applied directly on the floor by using microfiber cloth. After application, polishing the surface with high speed machine (pag. 61).

BURNISHING

Burnish with **Shine Pro BUFF** diamond floor pad specially designed for burnishing and polishing concrete floors (pag. 33-35).



Concrete Hardner Lithium

Lithium densifier High concentration, excellent oil-repellent, does not create film
- *Instruction pag. 59*



HD COPPER
grit 100



CALIBRA
grit 100



NATO CONCRETE
grit 200



NATO CONCRETE
grit 400

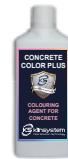

Concrete Color Plus (Liquid)

Concentrated liquid color solution to be diluted in 4 liters of Acetone
- *Instruction pag. 62*



V-HARR
grit 800

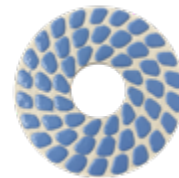

V-HARR
grit 1800



Marble POLISHING SYSTEM

GRINDING

Start grinding WET with SA SUPERTHICK metal bond discs grit 46, 70, 120. Recommended speed 550-650 rpm.

HONING

Continue WET with Spiral resin discs grit 220 and grit 400. Recommended speed 650-750 rpm.

POLISHING

Continue WET with NATO STONE resin bond discs grit 800 and grit 1800. Recommended speed 800-1100 rpm.

POLISH POWDER

As a final step for high gloss, use the most specific POLISH POWDER KS for marble in according to the kind of floor with PADLUX Natural fibers floor pads (*More info pag. 66*).

CLEANING AND SEALING

Wash the floors with water and Klinsoap to protect the surface and to improve the gloss (pag. 65). High quality combination cleaner that forms a water insoluble and dirt repellent barrier.



SA SUPERTHICK
Metal Bond



SPIRAL
grit 220



SPIRAL
grit 400



NATO STONE
grit 800



NATO STONE
grit 1800



Klinsoap

Dilute by 0,5 liters every 10 liters of water for daily cleaning and increase to 1-2 liters per 10 liters for added sealing impregnation effect.

Terrazzo POLISHING SYSTEM

GRINDING

Start grinding WET with SA SUPERTHICK metal bond diamond discs, grit 46 and grit 70. For terrazzo restoration start with grit 70. Recommended speed 550-650 rpm.

GROUTING

For cementitious terrazzo use densifier Concrete Hardner KS10 after grit 70 or before grit 100. Dry the surface and apply grout if needed, taking care to fill cracks (*More info pag. 63*).

FINE GRINDING

Grinding WET with SA SUPERTHICK discs grit 120 until all grout is removed from surface. If grout was not used on the floor, use CALIBRA grit 100, wet. Recommended speed 550-650 rpm.

HONING

Continue WET with NATO STONE resin bond discs grit 200 and grit 400. Recommended speed 650-750 rpm.

POLISHING

Polish with V-HARR resin bond discs grit 800 and grit 1800. Recommended speed 800-1100 rpm.

POLISH POWDER

As a final step for high shine, use **Polish Powder Mosaic** with PADLUX Natural fibers floor pads ideal for mosaic, terrazzo and palladiana floors (*More info pag. 70*).



SA SUPERTHICK
Metal Bond



POLYESTER MASTIC for
marble and terrazzo.



SA Superthick
grit 120



CALIBRA
grit 100



NATO STONE
grit 200



NATO STONE
grit 400



V-HARR
grit 800

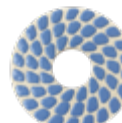

V-HARR
grit 1800



CLEANING AND SEALING

Wash the floors with water and Klinsoap to protect the surface and to improve the gloss. (*More info pag. 65*).

Floor Preparation

PCD TOOLS

Ideal for coating removal and preparation for epoxy. Offered with and without a metal button or sacrificial bars.

PCD's without metal button or sacrificial bars are very aggressive and designed for thick coating removal. They will leave a very coarse profile on the concrete floor.

PCD's with a metal button or sacrificial bars are less aggressive and are designed for thin coating removal.

Important:

PCD tools are direction specific. Always check the direction of rotation of the grinding heads.

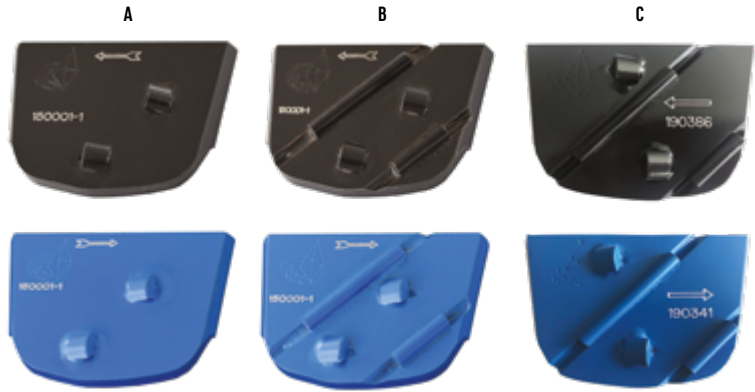

more aggressive →

CODE	DESCRIPTION	PRICE
EPCD	QC Trapezoid tool with 2 PCD segments	€ 86,00
EPCDSB	QC Trapezoid tool with 2 PCD segments and sacrificial bars	€ 105,00
X1B-PCD2	QC Trapezoid tool with 2 PCD segments and round metal button grit 30	€ 150,00

QUICK CHANGE METAL BOND TOOLS

Our Quick Change system features replaceable trapezoid-style pads that easily slide in and out of the machine plates or heads, with no bolting required. Quick Change tools are offered in separate bonds for soft, medium, hard, super hard and extra hard concrete floors.







TOOLING TIPS

- Use the rectangular 2 segments tools for a more aggressive cut and for no-cementitious coating removal.
- Use the round 2 buttons tools for cementitious coating removal.
- Use single round button tools with lighter machines (under 25").
- Use double segment tools with heavier machines 25" and up.
- For a more aggressive cut, use the single rectangular segment tools during the first grinding step on all machines (tool life can vary based on the concrete hardness).

Floor Preparation





SOFT CONCRETE

MOHS scale 2-3 - Concrete with a PSI under 2500 is considered soft / abrasive. We recommend to use Yellow bond.

	CODE	DESCRIPTION			GRIT	PRICE
	X1B-SC-0014	Quick Change	One button	for SOFT/ABRASIVE concrete	14	€ 49,50
	X1B-SC-0030	Quick Change	One button	for SOFT/ABRASIVE concrete	30	€ 37,50
	X1B-SC-0050	Quick Change	One button	for SOFT/ABRASIVE concrete	50	€ 37,50
	X1B-SC-0070	Quick Change	One button	for SOFT/ABRASIVE concrete	70	€ 37,50
	X1B-SC-0120	Quick Change	One button	for SOFT/ABRASIVE concrete	120	€ 37,50
	X2B-SC-0014	Quick Change	Two buttons	for SOFT/ABRASIVE concrete	14	€ 82,00
	X2B-SC-0030	Quick Change	Two buttons	for SOFT/ABRASIVE concrete	30	€ 63,50
	X2B-SC-0050	Quick Change	Two buttons	for SOFT/ABRASIVE concrete	50	€ 63,50
	X2B-SC-0070	Quick Change	Two buttons	for SOFT/ABRASIVE concrete	70	€ 63,50
	X2B-SC-0120	Quick Change	Two buttons	for SOFT/ABRASIVE concrete	120	€ 63,50
	X15-SC-0014	Quick Change	One segment	for SOFT/ABRASIVE concrete	14	€ 49,50
	X15-SC-0030	Quick Change	One segment	for SOFT/ABRASIVE concrete	30	€ 37,50
	X15-SC-0050	Quick Change	One segment	for SOFT/ABRASIVE concrete	50	€ 37,50
	X15-SC-0070	Quick Change	One segment	for SOFT/ABRASIVE concrete	70	€ 37,50
	X15-SC-0120	Quick Change	One segment	for SOFT/ABRASIVE concrete	120	€ 37,50
	X25-SC-0014	Quick Change	Two segments	for SOFT/ABRASIVE concrete	14	€ 82,00
	X25-SC-0030	Quick Change	Two segments	for SOFT/ABRASIVE concrete	30	€ 63,50
	X25-SC-0050	Quick Change	Two segments	for SOFT/ABRASIVE concrete	50	€ 63,50
	X25-SC-0070	Quick Change	Two segments	for SOFT/ABRASIVE concrete	70	€ 63,50
	X25-SC-0120	Quick Change	Two segments	for SOFT/ABRASIVE concrete	120	€ 63,50

MEDIUM CONCRETE

MOHS scale 3-5 - Concrete with a PSI between 2500 and 4000 is considered medium. We recommend to use Grey bond.

	CODE	DESCRIPTION			GRIT	PRICE
	X1B-MC-0014	Quick Change	One button	for MEDIUM concrete	14	€ 43,00
	X1B-MC-0030	Quick Change	One button	for MEDIUM concrete	30	€ 32,00
	X1B-MC-0050	Quick Change	One button	for MEDIUM concrete	50	€ 32,00
	X1B-MC-0070	Quick Change	One button	for MEDIUM concrete	70	€ 32,00
	X1B-MC-0120	Quick Change	One button	for MEDIUM concrete	120	€ 32,00
	X2B-MC-0014	Quick Change	Two buttons	for MEDIUM concrete	14	€ 77,00
	X2B-MC-0030	Quick Change	Two buttons	for MEDIUM concrete	30	€ 52,00
	X2B-MC-0050	Quick Change	Two buttons	for MEDIUM concrete	50	€ 52,00
	X2B-MC-0070	Quick Change	Two buttons	for MEDIUM concrete	70	€ 52,00
	X2B-MC-0120	Quick Change	Two buttons	for MEDIUM concrete	120	€ 52,00
	X15-MC-0014	Quick Change	One segment	for MEDIUM concrete	14	€ 43,00
	X15-MC-0030	Quick Change	One segment	for MEDIUM concrete	30	€ 32,00
	X15-MC-0050	Quick Change	One segment	for MEDIUM concrete	50	€ 32,00
	X15-MC-0070	Quick Change	One segment	for MEDIUM concrete	70	€ 32,00
	X15-MC-0120	Quick Change	One segment	for MEDIUM concrete	120	€ 32,00
	X25-MC-0014	Quick Change	Two segments	for MEDIUM concrete	14	€ 77,00
	X25-MC-0030	Quick Change	Two segments	for MEDIUM concrete	30	€ 52,00
	X25-MC-0050	Quick Change	Two segments	for MEDIUM concrete	50	€ 52,00
	X25-MC-0070	Quick Change	Two segments	for MEDIUM concrete	70	€ 52,00
	X25-MC-0120	Quick Change	Two segments	for MEDIUM concrete	120	€ 52,00

Floor Preparation



HARD CONCRETE

MOHS scale 5-7 - Concrete with a PSI between 4000 and 5000 is considered hard. We recommend to use Red bond.

	CODE	DESCRIPTION			GRIT	PRICE
	X1B-HC-0030	Quick Change	One button	for HARD concrete	30	€ 28,00
	X1B-HC-0050	Quick Change	One button	for HARD concrete	50	€ 28,00
	X1B-HC-0070	Quick Change	One button	for HARD concrete	70	€ 28,00
	X1B-HC-0120	Quick Change	One button	for HARD concrete	120	€ 28,00
	X2B-HC-0014	Quick Change	Two buttons	for HARD concrete	14	€ 68,50
	X2B-HC-0030	Quick Change	Two buttons	for HARD concrete	30	€ 47,00
	X2B-HC-0050	Quick Change	Two buttons	for HARD concrete	50	€ 47,00
	X2B-HC-0070	Quick Change	Two buttons	for HARD concrete	70	€ 47,00
	X1S-HC-0014	Quick Change	One segment	for HARD concrete	14	€ 45,00
	X1S-HC-0030	Quick Change	One segment	for HARD concrete	30	€ 28,00
	X1S-HC-0050	Quick Change	One segment	for HARD concrete	50	€ 28,00
	X1S-HC-0070	Quick Change	One segment	for HARD concrete	70	€ 28,00
	X2S-HC-0014	Quick Change	Two segments	for HARD concrete	14	€ 68,50
	X2S-HC-0030	Quick Change	Two segments	for HARD concrete	30	€ 47,00
	X2S-HC-0050	Quick Change	Two segments	for HARD concrete	50	€ 47,00
	X2S-HC-0070	Quick Change	Two segments	for HARD concrete	70	€ 47,00
	X2S-HC-0120	Quick Change	Two segments	for HARD concrete	120	€ 47,00



VERY HARD CONCRETE

MOHS scale 7-9 - Concrete with a PSI higher than 5500 is considered very hard. We recommend to use Gold bond.

	CODE	DESCRIPTION			GRIT	PRICE
	X1B-HCG-0030	Quick Change	One button	for VERY HARD concrete	30	€ 33,00
	X1B-HCG-0050	Quick Change	One button	for VERY HARD concrete	50	€ 33,00
	X1B-HCG-0070	Quick Change	One button	for VERY HARD concrete	70	€ 33,00
	X1B-HCG-0120	Quick Change	One button	for VERY HARD concrete	120	€ 33,00
	X2B-HCG-0030	Quick Change	Two buttons	for VERY HARD concrete	30	€ 55,50
	X2B-HCG-0050	Quick Change	Two buttons	for VERY HARD concrete	50	€ 55,50
	X2B-HCG-0070	Quick Change	Two buttons	for VERY HARD concrete	70	€ 55,50
	X2B-HCG-0120	Quick Change	Two buttons	for VERY HARD concrete	120	€ 55,50
	X1S-HCG-0030	Quick Change	One segment	for VERY HARD concrete	30	€ 33,00
	X1S-HCG-0050	Quick Change	One segment	for VERY HARD concrete	50	€ 33,00
	X1S-HCG-0070	Quick Change	One segment	for VERY HARD concrete	70	€ 33,00
	X1S-HCG-0120	Quick Change	One segment	for VERY HARD concrete	120	€ 33,00
	X2S-HCG-0030	Quick Change	Two segments	for VERY HARD concrete	30	€ 55,50
	X2S-HCG-0050	Quick Change	Two segments	for VERY HARD concrete	50	€ 55,50
	X2S-HCG-0070	Quick Change	Two segments	for VERY HARD concrete	70	€ 55,50
	X2S-HCG-0120	Quick Change	Two segments	for VERY HARD concrete	120	€ 55,50



EXTRA HARD CONCRETE

MOHS scale 7-9 - Concrete with a PSI over 7000 is considered extra hard. We recommend to use White bond.

	CODE	DESCRIPTION			GRIT	PRICE
	X1S-SHC-0030	Quick Change	One segment	for EXTRA HARD concrete	30	€ 33,00
	X1S-SHC-0050	Quick Change	One segment	for EXTRA HARD concrete	50	€ 33,00
	X1S-SHC-0070	Quick Change	One segment	for EXTRA HARD concrete	70	€ 33,00
	X1S-SHC-0120	Quick Change	One segment	for EXTRA HARD concrete	120	€ 33,00
	X2S-SHC-0030	Quick Change	Two segments	for EXTRA HARD concrete	30	€ 55,50
	X2S-SHC-0050	Quick Change	Two segments	for EXTRA HARD concrete	50	€ 55,50
	X2S-SHC-0070	Quick Change	Two segments	for EXTRA HARD concrete	70	€ 55,50
	X2S-SHC-0120	Quick Change	Two segments	for EXTRA HARD concrete	120	€ 55,50

Floor Preparation

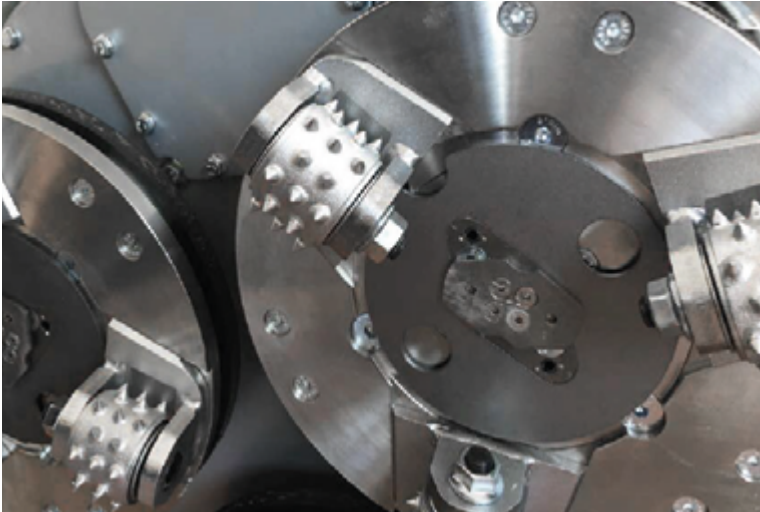

BUSH HAMMER SYSTEM

The bush hammers are aggressive tools for concrete profiling and texturing. They create a very rough surface. Ideal for preparation, as well as for outdoor applications requiring non-slip surfaces.

Each bush hammer roller is attached to our standard Quick Change trapezoid pad that easily slide in and out the tool holder plate.

You can use them on our machines and other grinders using Quick Change adapter plates.

Recommended speed around 500-700 rpm.

Always attach the security rings for safe operation.



BUSH HAMMER

special tooling bsystem suitable for many applications:

- To make safety anti-slip surfaces on marble, granite and natural stones,
- To remove glue, varnish and resin coating.
- To break-down thick coating difficult to remove with normal diamond tools.
- To create "face-see effect" on precast panels".
- To scarify any kind of surface.
- To create orange-peel skin on any surface.

For floor preparation, using Bush Hammer in combination with diamond tools it is possible to prepare in the best way the surface in order to apply correctly the new coating.



CODE	DESCRIPTION	PRICE
X-BH-3	QC Bush hammer tools, Set of 3 pcs + 1 security ring	€ 730,00

Concrete POLISHING

RECOMMENDED RPM

COATING REMOVAL: 550-650 RPM

- ▶ Carbide scrapers
- ▶ Bush hammers
- ▶ PCD Tools

GRINDING: 550-650 RPM

- ▶ Quick Change Metal Bond Tools
- ▶ SA - MB Disks

TRANSITIONING

& HONING: 650-750 RPM

- ▶ HD Copper
- ▶ Calibra
- ▶ Corsa Hybrids
- ▶ Resin Tools, 200 - 400 Grit

POLISHING: 800-1100 RPM

- ▶ Resin Tools, 800 - 1800 - 3500 Grit



3-STEP CONCRETE POLISHING SYSTEM

3" pads, featuring a new proprietary resin bond formula and suitable for any type of concrete.

Can be used Wet or Dry on almost any concrete polishing machine, using a velcro plate / tool holder.

The floor should be cut to 120 grit with a metal or hybrid diamond tool and densified, if necessary, before starting with step 1.

CODE	DESCRIPTION	SIZE	THICKNESS	PRICE
3S-1	3-Step floor polishing system, Step 1	80mm / 3"	9mm	€ 43,00
3S-2	3-Step floor polishing system, Step 2	80mm / 3"	9mm	€ 43,00
3S-3	3-Step floor polishing system, Step 3	80mm / 3"	9mm	€ 43,00

HD RESIN

Designed for heavier grinders (30" and up). Make sure you add weights if you are using them on lighter machines. Available in 3" and 4" sizes. Velcro connection. **Can be used Wet or Dry.**

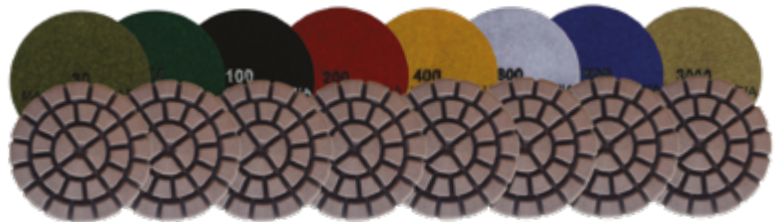

CODE	DESCRIPTION	SIZE	THICKNESS	PRICE
HD-3-0030R	HD Resin Pad GRIT 30	80mm / 3"	8mm	€ 38,00
HD-3-0050R	HD Resin Pad GRIT 50	80mm / 3"	8mm	€ 38,00
HD-3-0100R	HD Resin Pad GRIT 100	80mm / 3"	8mm	€ 38,00
HD-3-0200R	HD Resin Pad GRIT 200	80mm / 3"	8mm	€ 38,00
HD-3-0400R	HD Resin Pad GRIT 400	80mm / 3"	8mm	€ 38,00
HD-3-0800R	HD Resin Pad GRIT 800	80mm / 3"	8mm	€ 38,00
HD-3-1500R	HD Resin Pad GRIT 1500	80mm / 3"	8mm	€ 38,00
HD-3-3000R	HD Resin Pad GRIT 3000	80mm / 3"	8mm	€ 38,00

CODE	DESCRIPTION	SIZE	THICKNESS	PRICE
HD-4-0030R	HD Resin Pad GRIT 30	100mm / 4"	8mm	€ 47,00
HD-4-0050R	HD Resin Pad GRIT 50	100mm / 4"	8mm	€ 47,00
HD-4-0100R	HD Resin Pad GRIT 100	100mm / 4"	8mm	€ 47,00
HD-4-0200R	HD Resin Pad GRIT 200	100mm / 4"	8mm	€ 47,00
HD-4-0400R	HD Resin Pad GRIT 400	100mm / 4"	8mm	€ 47,00
HD-4-0800R	HD Resin Pad GRIT 800	100mm / 4"	8mm	€ 47,00
HD-4-1500R	HD Resin Pad GRIT 1500	100mm / 4"	8mm	€ 47,00
HD-4-3000R	HD Resin Pad GRIT 3000	100mm / 4"	8mm	€ 47,00

Concrete POLISHING

HD COPPER

Can be used for the first grinding steps on big box retail projects and provide a fast cut and long tool life. **They should be used Wet only!** Velcro connection.



CODE	DESCRIPTION	SIZE	THICKN.	PRICE
HD-3-CO-0050R	HD Copper pad GRIT 50	80mm/3"	8mm	€ 42,00
HD-3-CO-0100R	HD Copper pad GRIT 100	80mm/3"	8mm	€ 42,00
HD-3-CO-0200R	HD Copper pad GRIT 200	80mm/3"	8mm	€ 42,00
HD-3-CO-0400R	HD Copper pad GRIT 400	80mm/3"	8mm	€ 42,00



3N COPPER

An excellent solution for corner grinding and honing. Available in 4" and 5" sizes. Velcro connection.

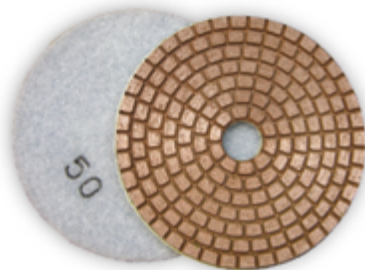

CODE	DESCRIPTION	SIZE	PRICE
3N-4-CO030	3N Copper Pad -Polishing GRIT 30	100mm / 4"	€ 37,50
3N-4-CO050	3N Copper Pad -Polishing GRIT 50	100mm / 4"	€ 37,50
3N-4-CO070	3N Copper Pad -Polishing GRIT 70	100mm / 4"	€ 37,50
3N-4-CO120	3N Copper Pad -Polishing GRIT 120	100mm / 4"	€ 37,50
3N-4-CO220	3N Copper Pad -Polishing GRIT 220	100mm / 4"	€ 37,50

CODE	DESCRIPTION	SIZE	PRICE
3N-5-CO030	3N Copper Pad -Polishing GRIT 30	125mm / 5"	€ 51,50
3N-5-CO050	3N Copper Pad -Polishing GRIT 50	125mm / 5"	€ 51,50
3N-5-CO070	3N Copper Pad -Polishing GRIT 70	125mm / 5"	€ 51,50
3N-5-CO120	3N Copper Pad -Polishing GRIT 120	125mm / 5"	€ 51,50
3N-5-CO220	3N Copper Pad -Polishing GRIT 220	125mm / 5"	€ 51,50

3N HIGH PERFORMANCE POLISHING PAD

The go-to solution for concrete countertop professionals. Featuring a **dry-only High Performance bond**, these pads achieve an exceptionally smooth and even polish on concrete countertops. Available in 4" and 5" sizes. Velcro connection.

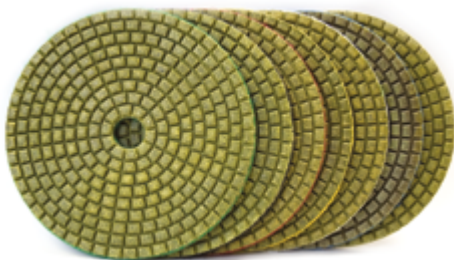

CODE	DESCRIPTION	SIZE	PRICE
3N-HP-4-0050	3N Hi-Perf Pads, Resin GRIT 50	100mm / 4"	€ 29,00
3N-HP-4-0100	3N Hi-Perf Pads, Resin GRIT 100	100mm / 4"	€ 29,00
3N-HP-4-0200	3N Hi-Perf Pads, Resin GRIT 200	100mm / 4"	€ 29,00
3N-HP-4-0400	3N Hi-Perf Pads, Resin GRIT 400	100mm / 4"	€ 29,00
3N-HP-4-0800	3N Hi-Perf Pads, Resin GRIT 800	100mm / 4"	€ 29,00
3N-HP-4-1500	3N Hi-Perf Pads, Resin GRIT 1500	100mm / 4"	€ 29,00
3N-HP-4-3000	3N Hi-Perf Pads, Resin GRIT 3000	100mm / 4"	€ 29,00
3N-HP-4-BUFF	3N Hi-Perf Pads, Resin GRIT BUFF	100mm / 4"	€ 29,00

CODE	DESCRIPTION	SIZE	PRICE
3N-HP-5-0050	3N Hi-Perf Pads, Resin GRIT 50	125mm / 5"	€ 36,50
3N-HP-5-0100	3N Hi-Perf Pads, Resin GRIT 100	125mm / 5"	€ 36,50
3N-HP-5-0200	3N Hi-Perf Pads, Resin GRIT 200	125mm / 5"	€ 36,50
3N-HP-5-0400	3N Hi-Perf Pads, Resin GRIT 400	125mm / 5"	€ 36,50
3N-HP-5-0800	3N Hi-Perf Pads, Resin GRIT 800	125mm / 5"	€ 36,50
3N-HP-5-1500	3N Hi-Perf Pads, Resin GRIT 1500	125mm / 5"	€ 36,50
3N-HP-5-3000	3N Hi-Perf Pads, Resin GRIT 3000	125mm / 5"	€ 36,50
3N-HP-5-BUFF	3N Hi-Perf Pads, Resin GRIT BUFF	125mm / 5"	€ 36,50

CALIBRA CERAMIC PADS

Remove difficult scratches which are left behind by the metal bond grinding steps. Calibra are best for hard and medium concrete applications (their life is shorter on soft or abrasive floors). **Can be used Wet or Dry.**



CODE	DESCRIPTION	SIZE	THICKN.	PRICE
CA3-30	Calibra ceramic pad GRIT 30	80mm / 3"	10mm	€ 47,50
CA3-50	Calibra ceramic pad GRIT 50	80mm / 3"	10mm	€ 47,50
CA3-100	Calibra ceramic pad GRIT 100	80mm / 3"	10mm	€ 47,50
CA3-200	Calibra ceramic pad GRIT 200	80mm / 3"	10mm	€ 47,50

Concrete POLISHING

WAFFEL Polishing Pads

Waffel Polishing Pads features a triple segmented resin ring (3 rows) for use under larger machines. Suitable for hard concrete applications. Waffel polishing pads are ideal for Trowel Shine Polishing System (see pag. 36-37).

Wet&Dry use. Standard velcro attachment.

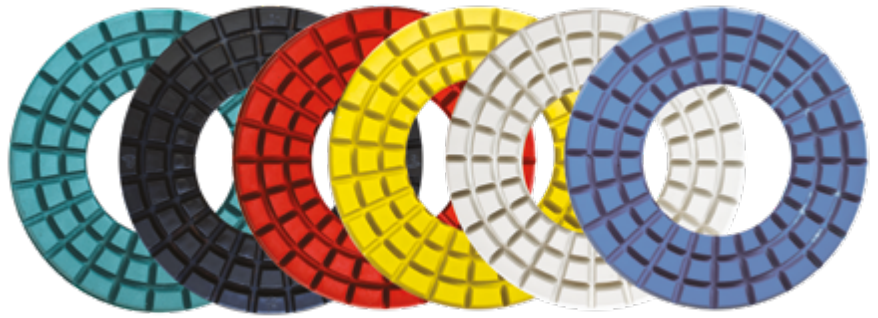

CODE	DESCRIPTION	SIZE	THICKNESS	PRICE
WAFF-7-0030D	WAFFEL GRIT 30	175mm/7"	10mm	€ 67,00
WAFF-7-0050D	WAFFEL GRIT 50	175mm/7"	10mm	€ 67,00
WAFF-7-0100D	WAFFEL GRIT 100	175mm/7"	10mm	€ 67,00
WAFF-7-0200D	WAFFEL GRIT 200	175mm/7"	10mm	€ 67,00
WAFF-7-0400D	WAFFEL GRIT 400	175mm/7"	10mm	€ 67,00
WAFF-7-0600D	WAFFEL GRIT 600	175mm/7"	10mm	€ 67,00
WAFF-7-0800D	WAFFEL GRIT 800	175mm/7"	10mm	€ 67,00
WAFF-7-1500D	WAFFEL GRIT 1500	175mm/7"	10mm	€ 67,00
WAFF-7-3000D	WAFFEL GRIT 3000	175mm/7"	10mm	€ 67,00

CODE	DESCRIPTION	SIZE	THICKNESS	PRICE
WAFF-10,63-0030D	WAFFEL GRIT 30	275mm/10,63"	10mm	€ 143,00
WAFF-10,63-0050D	WAFFEL GRIT 50	275mm/10,63"	10mm	€ 143,00
WAFF-10,63-0100D	WAFFEL GRIT 100	275mm/10,63"	10mm	€ 143,00
WAFF-10,63-0200D	WAFFEL GRIT 200	275mm/10,63"	10mm	€ 143,00
WAFF-10,63-0400D	WAFFEL GRIT 400	275mm/10,63"	10mm	€ 143,00
WAFF-10,63-0600D	WAFFEL GRIT 600	275mm/10,63"	10mm	€ 143,00
WAFF-10,63-0800D	WAFFEL GRIT 800	275mm/10,63"	10mm	€ 143,00
WAFF-10,63-1500D	WAFFEL GRIT 1500	275mm/10,63"	10mm	€ 143,00
WAFF-10,63-3000D	WAFFEL GRIT 3000	275mm/10,63"	10mm	€ 143,00

CODE	DESCRIPTION	SIZE	THICKNESS	PRICE
WAFF-9-0030D	WAFFEL GRIT 30	230mm/9"	10mm	€ 129,00
WAFF-9-0050D	WAFFEL GRIT 50	230mm/9"	10mm	€ 129,00
WAFF-9-0100D	WAFFEL GRIT 100	230mm/9"	10mm	€ 129,00
WAFF-9-0200D	WAFFEL GRIT 200	230mm/9"	10mm	€ 129,00
WAFF-9-0400D	WAFFEL GRIT 400	230mm/9"	10mm	€ 129,00
WAFF-9-0600D	WAFFEL GRIT 600	230mm/9"	10mm	€ 129,00
WAFF-9-0800D	WAFFEL GRIT 800	230mm/9"	10mm	€ 129,00
WAFF-9-1500D	WAFFEL GRIT 1500	230mm/9"	10mm	€ 129,00
WAFF-9-3000D	WAFFEL GRIT 3000	230mm/9"	10mm	€ 129,00

CODE	DESCRIPTION	SIZE	THICKNESS	PRICE
WAFF-14-0030D	WAFFEL GRIT 30	356mm/14"	10mm	€ 182,00
WAFF-14-0050D	WAFFEL GRIT 50	356mm/14"	10mm	€ 182,00
WAFF-14-0100D	WAFFEL GRIT 100	356mm/14"	10mm	€ 182,00
WAFF-14-0200D	WAFFEL GRIT 200	356mm/14"	10mm	€ 182,00
WAFF-14-0400D	WAFFEL GRIT 400	356mm/14"	10mm	€ 182,00
WAFF-14-0600D	WAFFEL GRIT 600	356mm/14"	10mm	€ 182,00
WAFF-14-0800D	WAFFEL GRIT 800	356mm/14"	10mm	€ 182,00
WAFF-14-1500D	WAFFEL GRIT 1500	356mm/14"	10mm	€ 182,00
WAFF-14-3000D	WAFFEL GRIT 3000	356mm/14"	10mm	€ 182,00

WAFFEL QUICK CHANGE Polishing Pads

Waffel Polishing Pads features a triple segmented resin (3 rows) for use under larger machines. Suitable for hard concrete applications.

Wet&Dry use. Quick change attachment.



CODE	DESCRIPTION	SIZE	THICKNESS	PRICE
XQCWF0030D	WAFFEL GRIT 30	standard	10mm	€ 38,50
XQCWF0050D	WAFFEL GRIT 50	standard	10mm	€ 38,50
XQCWF0100D	WAFFEL GRIT 100	standard	10mm	€ 38,50
XQCWF0200D	WAFFEL GRIT 200	standard	10mm	€ 38,50
XQCWF0400D	WAFFEL GRIT 400	standard	10mm	€ 38,50
XQCWF0800D	WAFFEL GRIT 800	standard	10mm	€ 38,50
XQCWF1500D	WAFFEL GRIT 1500	standard	10mm	€ 38,50

Concrete POLISHING



V-HARR Premium Polishing Pads

V-HARR Pads are the most versatile and popular polishing pads, designed for mechanically restoring and polishing concrete. V-HARR is also ideal for terrazzo and hard stone floors and will produce remarkable gloss results on black granite when used wet. Available also velcro attachment in many popular sizes for use with any planetary polisher (80mm / 3" - 127mm / 5" - 175mm / 7"). V-HARR Grit 1800 (Dry use) is ideal during Trowel Shine System after using Concrete Hard Lithium (see pag. 26-27). Velcro attachment. **Dry use is strongly recommended for concrete applications.**

CODE	DESCRIPTION	SIZE	THICKNESS	PRICE
VF-9-0050	V-HARR Polishing pad	GRIT 50	230mm / 9"	€ 92,00
VF-9-0120	V-HARR Polishing pad	GRIT 120	230mm / 9"	€ 92,00
VF-9-0220	V-HARR Polishing pad	GRIT 220	230mm / 9"	€ 92,00
VF-9-0400	V-HARR Polishing pad	GRIT 400	230mm / 9"	€ 92,00
VF-9-0800	V-HARR Polishing pad	GRIT 800	230mm / 9"	€ 92,00
VF-9-1800	V-HARR Polishing pad	GRIT 1800	230mm / 9"	€ 92,00
VF-9-3500	V-HARR Polishing pad	GRIT 3500	230mm / 9"	€ 92,00
VF-9-BUFF	V-HARR Polishing pad	GRIT BUFF	230mm / 9"	€ 92,00

CODE	DESCRIPTION	SIZE	THICKNESS	PRICE
VF-10,63-0050	V-HARR Polishing pad	GRIT 50	275mm/10,63"	€ 110,00
VF-10,63-0120	V-HARR Polishing pad	GRIT 120	275mm/10,63"	€ 110,00
VF-10,63-0220	V-HARR Polishing pad	GRIT 220	275mm/10,63"	€ 110,00
VF-10,63-0400	V-HARR Polishing pad	GRIT 400	275mm/10,63"	€ 110,00
VF-10,63-0800	V-HARR Polishing pad	GRIT 800	275mm/10,63"	€ 110,00
VF-10,63-1800	V-HARR Polishing pad	GRIT 1800	275mm/10,63"	€ 110,00
VF-10,63-3500	V-HARR Polishing pad	GRIT 3500	275mm/10,63"	€ 110,00
VF-10,63-BUFF	V-HARR Polishing pad	GRIT BUFF	275mm/10,63"	€ 110,00

CODE	DESCRIPTION	SIZE	THICKNESS	PRICE
VF-13,5-0220	V-HARR Polishing pad	GRIT 220	335mm / 13,5"	€ 134,00
VF-13,5-0400	V-HARR Polishing pad	GRIT 400	335mm / 13,5"	€ 134,00
VF-13,5-0800	V-HARR Polishing pad	GRIT 800	335mm / 13,5"	€ 134,00
VF-13,5-1800	V-HARR Polishing pad	GRIT 1800	335mm / 13,5"	€ 134,00
VF-13,5-3500	V-HARR Polishing pad	GRIT 3500	335mm / 13,5"	€ 134,00
VF-13,5-BUFF	V-HARR Polishing pad	GRIT BUFF	335mm / 13,5"	€ 134,00

CODE	DESCRIPTION	SIZE	THICKNESS	PRICE
VF-14-0220	V-HARR Polishing pad	GRIT 220	356mm/14"	€ 140,00
VF-14-0400	V-HARR Polishing pad	GRIT 400	356mm/14"	€ 140,00
VF-14-0800	V-HARR Polishing pad	GRIT 800	356mm/14"	€ 140,00
VF-14-1800	V-HARR Polishing pad	GRIT 1800	356mm/14"	€ 140,00
VF-14-3500	V-HARR Polishing pad	GRIT 3500	356mm/14"	€ 140,00
VF-14-BUFF	V-HARR Polishing pad	GRIT BUFF	356mm/14"	€ 140,00

V-HARR QUICK CHANGE Premium Polishing Pads



V-HARR QUICK CHANGE 9"

CODE	DESCRIPTION	SIZE	THICKNESS	PRICE
XQCVF0120	V-HARR Quick change	GRIT 120	XQC 9	€ 31,00
XQCVF0220	V-HARR Quick change	GRIT 220	XQC 9	€ 31,00
XQCVF0400	V-HARR Quick change	GRIT 400	XQC 9	€ 31,00
XQCVF0800	V-HARR Quick change	GRIT 800	XQC 9	€ 31,00
XQCVF1800	V-HARR Quick change	GRIT 1800	XQC 9	€ 31,00
XQCVF3500	V-HARR Quick change	GRIT 3500	XQC 9	€ 31,00
XQCVFBUFF	V-HARR Quick change	GRIT BUFF	XQC 9	€ 31,00

V-HARR QUICK CHANGE 13"

CODE	DESCRIPTION	SIZE	THICKNESS	PRICE
XQC13VF0220	V-HARR Quick change	GRIT 220	XQC 13	€ 23,00
XQC13VF0400	V-HARR Quick change	GRIT 400	XQC 13	€ 23,00
XQC13VF0800	V-HARR Quick change	GRIT 800	XQC 13	€ 23,00
XQC13VF1800	V-HARR Quick change	GRIT 1800	XQC 13	€ 23,00
XQC13VF3500	V-HARR Quick change	GRIT 3500	XQC 13	€ 23,00
XQC13VFBUFF	V-HARR Quick change	GRIT BUFF	XQC 13	€ 23,00

Concrete POLISHING

NATO CONCRETE

Wet and Dry Polishing Pads with wide channels and patented design allow to work on a cleaner surface, ensuring a quality polish. High quality, long lasting resin bond, can be used with all floor grinding machines with velcro connection. NATO pads feature a thick 12mm layer of resin and diamonds for extra long life.

- Available in 50, 100, 200, 400, 800, 1500 and 3000 Grit Polishing Discs
- Wide channels quickly clear out slurry or dust
- Available in 3" or 4" sizes and Velcro backing for quick change
- Thick 12 MM Layer of Resin and Diamonds result in Longer Lifespan compared to other polishing discs
- One of our most popular resin polishing pads for concrete applications
- Every NATO pad is appropriate for all concrete grinding/polishing applications
- Offered in wet and dry bond formulations



CODE	DESCRIPTION	SIZE	THICKNESS	PRICE
NS-0050D	NATO Concrete GRIT 50	80mm / 3"	12mm	€ 29,00
NS-0100D	NATO Concrete GRIT 100	80mm / 3"	12mm	€ 29,00
NS-0200D	NATO Concrete GRIT 200	80mm / 3"	12mm	€ 29,00
NS-0400D	NATO Concrete GRIT 400	80mm / 3"	12mm	€ 29,00
NS-0600D	NATO Concrete GRIT 600	80mm / 3"	12mm	€ 29,00
NS-0800D	NATO Concrete GRIT 800	80mm / 3"	12mm	€ 29,00
NS-1500D	NATO Concrete GRIT 1500	80mm / 3"	12mm	€ 29,00
NS-3000D	NATO Concrete GRIT 3000	80mm / 3"	12mm	€ 29,00

CODE	DESCRIPTION	SIZE	THICKNESS	PRICE
NS-4-0050D	NATO Concrete GRIT 50	100mm / 4"	12mm	€ 38,00
NS-4-0100D	NATO Concrete GRIT 100	100mm / 4"	12mm	€ 38,00
NS-4-0200D	NATO Concrete GRIT 200	100mm / 4"	12mm	€ 38,00
NS-4-0400D	NATO Concrete GRIT 400	100mm / 4"	12mm	€ 38,00
NS-4-0600D	NATO Concrete GRIT 600	100mm / 4"	12mm	€ 38,00
NS-4-0800D	NATO Concrete GRIT 800	100mm / 4"	12mm	€ 38,00
NS-4-1500D	NATO Concrete GRIT 1500	100mm / 4"	12mm	€ 38,00
NS-4-3000D	NATO Concrete GRIT 3000	100mm / 4"	12mm	€ 38,00

VELCRO PAD HOLDER

Velcro Pad Holder for resin tools and floor pads.



CODE	DESCRIPTION	PRICE
XQC-PH-9	Quick change Velcro Pad Holder for 230mm / 9" Kit 9 pcs	€ 172,00
XQC-PH-13	Quick change Velcro Pad Holder for 330mm / 13" Kit 18 pcs	€ 276,00

ALUMINUM HOLDERS

Aluminum Lippage Holders for velcro-backed tools. Sizes available: 100mm / 4" and 80mm / 3". Quick Change attachment to be used with Lavina Quick Change plates.



CODE	DESCRIPTION	SIZE	PRICE
XQC-4LH	Quick Change Aluminum Lippage Holder	100mm / 4"	€ 57,60
XQC-83LH	Quick Change Aluminum Lippage Holder	80mm / 3"	€ 45,50

CAMLOCK CONNECTION



CODE	DESCRIPTION	PRICE
30316000059	Camlock connection for L20	€ 21,50
C250-AL	Camlock connection for L25	€ 50,50
A67.00.00	Camlock connection for L30L	€ 64,00
30316000044	Camlock connection for L32	€ 39,00

Marble & Natural Stone

SA SUPERTHICK Metal Bond

Suitable for grinding concrete, natural stone, self-leveling and terrazzo floors! The SA metal discs provide a great first cut with a smooth and refined scratch pattern. Available also Velcro connection. **Only wet use.** XQC Grit 30 Terrazzo bond Euro 129,00.

CODE	DESCRIPTION	SIZE	THICKNESS	PRICE
XQC-SA-046MB	SA Superthick disc GRIT 46	80mm / 3"	4mm	€ 119,00
XQC-SA-070MB	SA Superthick disc GRIT 70	80mm / 3"	4mm	€ 119,00
XQC-SA-120MB	SA Superthick disc GRIT 120	80mm / 3"	4mm	€ 119,00
XQC-SA-220MB	SA Superthick disc GRIT 220	80mm / 3"	4mm	€ 119,00



SPIRAL Polishing Pads

The undisputed solution for polishing natural stone floors. Both spiral patterns enable water to efficiently dispose of slurry, keeping the working surface clean. The standard spiral pattern is designed for medium to softer stones, such as marble, travertine, onyx and limestone. The wide channel pattern with a larger footprint is more appropriate for harder stone such as granite. Only wet system. Velcro connection.

CODE	DESCRIPTION	SIZE	THICKNESS	PRICE
10-3-0030	Spiral Polishing Pad GRIT 30	80mm / 3"	6mm	€ 24,00
10-3-0050	Spiral Polishing Pad GRIT 50	80mm / 3"	6mm	€ 24,00
10-3-0120	Spiral Polishing Pad GRIT 120	80mm / 3"	6mm	€ 24,00
10-3-0220	Spiral Polishing Pad GRIT 220	80mm / 3"	6mm	€ 24,00
10-3-0400	Spiral Polishing Pad GRIT 400	80mm / 3"	6mm	€ 24,00
10-3-0800	Spiral Polishing Pad GRIT 800	80mm / 3"	6mm	€ 24,00
10-3-1800	Spiral Polishing Pad GRIT 1800	80mm / 3"	6mm	€ 24,00
10-3-3500	Spiral Polishing Pad GRIT 3500	80mm / 3"	6mm	€ 24,00
10-3-8500	Spiral Polishing Pad GRIT 8500	80mm / 3"	6mm	€ 24,00



NATO STONE Polishing Pads

Resin bond diamond tools for grinding, polishing and restoration of marble and natural stone. Wide channels and patented design allow to work on a cleaner surface, ensuring a quality polish. NATO pads feature a thick 12mm layer of resin and diamonds for extra long life. High quality, long lasting resin bond, can be used with all floor grinding machines with velcro connection. We recommend a minimum of 3 discs per head for optimum performance. **Only WET use.**

CODE	DESCRIPTION	SIZE	THICKNESS	PRICE
NS-0030	NATO Stone GRIT 30	80mm / 3"	12mm	€ 30,00
NS-0050	NATO Stone GRIT 50	80mm / 3"	12mm	€ 30,00
NS-0100	NATO Stone GRIT 100	80mm / 3"	12mm	€ 30,00
NS-0200	NATO Stone GRIT 200	80mm / 3"	12mm	€ 30,00
NS-0400	NATO Stone GRIT 400	80mm / 3"	12mm	€ 30,00
NS-0600	NATO Stone GRIT 600	80mm / 3"	12mm	€ 30,00
NS-0800	NATO Stone GRIT 800	80mm / 3"	12mm	€ 30,00
NS-1500	NATO Stone GRIT 1500	80mm / 3"	12mm	€ 30,00
NS-3000	NATO Stone GRIT 3000	80mm / 3"	12mm	€ 30,00



Diamond Polishing Pads

SHINEPRO PLUS Diamond Floor Pads

High Flexibility - High Performance - Heavy Duty

ShinePro Plus polishing pads are an efficient and versatile solution for floor restoration and maintenance and provide outstanding results on polished Concrete, Marble, Terrazzo, Ceramic, Klinker floors, Natural stone, PVC, Rubber, Vinyl, Epoxy and Wooden floors. **Only water!**

- Standard **velcro connection** for a quick and easy tool attachment
- Offered in all popular **sizes from 125mm up to 510mm**.
- Easy to use with standard single disc machine or with Orbital machines
- Available in several **Grit range from 50 to 3500**



CODE	DESCRIPTION	SIZE	PRICE
SPP-5-0050	SHINEPRO PLUS GRIT 50	125mm / 5"	€ 24,00
SPP-5-0120	SHINEPRO PLUS GRIT 120	125mm / 5"	€ 24,00
SPP-5-0220	SHINEPRO PLUS GRIT 220	125mm / 5"	€ 24,00
SPP-5-0400	SHINEPRO PLUS GRIT 400	125mm / 5"	€ 24,00
SPP-5-0800	SHINEPRO PLUS GRIT 800	125mm / 5"	€ 24,00
SPP-5-1800	SHINEPRO PLUS GRIT 1800	125mm / 5"	€ 24,00
SPP-5-3500	SHINEPRO PLUS GRIT 3500	125mm / 5"	€ 24,00
SPP-9-0050	SHINEPRO PLUS GRIT 50	230mm / 9"	€ 53,00
SPP-9-0120	SHINEPRO PLUS GRIT 120	230mm / 9"	€ 53,00
SPP-9-0220	SHINEPRO PLUS GRIT 220	230mm / 9"	€ 53,00
SPP-9-0400	SHINEPRO PLUS GRIT 400	230mm / 9"	€ 53,00
SPP-9-0800	SHINEPRO PLUS GRIT 800	230mm / 9"	€ 53,00
SPP-9-1800	SHINEPRO PLUS GRIT 1800	230mm / 9"	€ 53,00
SPP-9-3500	SHINEPRO PLUS GRIT 3500	230mm / 9"	€ 53,00
SPP-13-0050	SHINEPRO PLUS GRIT 50	330mm / 13"	€ 93,00
SPP-13-0120	SHINEPRO PLUS GRIT 120	330mm / 13"	€ 93,00
SPP-13-0220	SHINEPRO PLUS GRIT 220	330mm / 13"	€ 93,00
SPP-13-0400	SHINEPRO PLUS GRIT 400	330mm / 13"	€ 93,00
SPP-13-0800	SHINEPRO PLUS GRIT 800	330mm / 13"	€ 93,00
SPP-13-1800	SHINEPRO PLUS GRIT 1800	330mm / 13"	€ 93,00
SPP-13-3500	SHINEPRO PLUS GRIT 3500	330mm / 13"	€ 93,00

CODE	DESCRIPTION	SIZE	PRICE
SPP-14-0050	SHINEPRO PLUS GRIT 50	356mm / 14"	€ 102,00
SPP-14-0120	SHINEPRO PLUS GRIT 120	356mm / 14"	€ 102,00
SPP-14-0220	SHINEPRO PLUS GRIT 220	356mm / 14"	€ 102,00
SPP-14-0400	SHINEPRO PLUS GRIT 400	356mm / 14"	€ 102,00
SPP-14-0800	SHINEPRO PLUS GRIT 800	356mm / 14"	€ 102,00
SPP-14-1800	SHINEPRO PLUS GRIT 1800	356mm / 14"	€ 102,00
SPP-14-3500	SHINEPRO PLUS GRIT 3500	356mm / 14"	€ 102,00
SPP-17-0050	SHINEPRO PLUS GRIT 50	430mm / 17"	€ 115,00
SPP-17-0120	SHINEPRO PLUS GRIT 120	430mm / 17"	€ 115,00
SPP-17-0220	SHINEPRO PLUS GRIT 220	430mm / 17"	€ 115,00
SPP-17-0400	SHINEPRO PLUS GRIT 400	430mm / 17"	€ 115,00
SPP-17-0800	SHINEPRO PLUS GRIT 800	430mm / 17"	€ 115,00
SPP-17-1800	SHINEPRO PLUS GRIT 1800	430mm / 17"	€ 115,00
SPP-17-3500	SHINEPRO PLUS GRIT 3500	430mm / 17"	€ 115,00
SPP-20-0050	SHINEPRO PLUS GRIT 50	510mm / 20"	€ 179,00
SPP-20-0120	SHINEPRO PLUS GRIT 120	510mm / 20"	€ 179,00
SPP-20-0220	SHINEPRO PLUS GRIT 220	510mm / 20"	€ 179,00
SPP-20-0400	SHINEPRO PLUS GRIT 400	510mm / 20"	€ 179,00
SPP-20-0800	SHINEPRO PLUS GRIT 800	510mm / 20"	€ 179,00
SPP-20-1800	SHINEPRO PLUS GRIT 1800	510mm / 20"	€ 179,00
SPP-20-3500	SHINEPRO PLUS GRIT 3500	510mm / 20"	€ 179,00

SHINEPRO SCREEN

Flexible Electroplated Screen

ShinePro Screen flexible Electroplated Screens ideal for aggressive cleaning, spot repair and floor restoration. Screens **Grit 220 and 400 are very aggressive** and designed for hard floors. The **Grit 600 is ideal for a satin smooth surface** effect. Suitable for compact grinders for smaller areas, burnisher or auto scrubbers up to 350 rpm for large areas. The ShinePro Screens system offers outstanding results and cost savings, extending the life of daily maintenance, reducing working times and consumption of chemicals.



CODE	DESCRIPTION	SIZE	PRICE
DS-13W-0220	SHINEPRO SCREEN GRIT 220	330mm / 13"	€ 125,00
DS-13W-0400	SHINEPRO SCREEN GRIT 400	330mm / 13"	€ 96,50
DS-13W-0600	SHINEPRO SCREEN GRIT 600	330mm / 13"	€ 70,00
DS-14W-0220	SHINEPRO SCREEN GRIT 220	356mm / 14"	€ 144,00
DS-14W-0400	SHINEPRO SCREEN GRIT 400	356mm / 14"	€ 120,00
DS-14W-0600	SHINEPRO SCREEN GRIT 600	356mm / 14"	€ 82,00
DS-17W-0220	SHINEPRO SCREEN GRIT 220	430mm / 17"	€ 178,00
DS-17W-0400	SHINEPRO SCREEN GRIT 400	430mm / 17"	€ 142,00
DS-17W-0600	SHINEPRO SCREEN GRIT 600	430mm / 17"	€ 99,00

CODE	DESCRIPTION	SIZE	PRICE
DS-20W-0220	SHINEPRO SCREEN GRIT 220	510mm / 20"	€ 218,00
DS-20W-0400	SHINEPRO SCREEN GRIT 400	510mm / 20"	€ 167,00
DS-20W-0600	SHINEPRO SCREEN GRIT 600	510mm / 20"	€ 133,00
DS-21W-0220	SHINEPRO SCREEN GRIT 220	540mm / 21"	€ 230,00
DS-21W-0400	SHINEPRO SCREEN GRIT 400	540mm / 21"	€ 183,00
DS-21W-0600	SHINEPRO SCREEN GRIT 600	540mm / 21"	€ 144,00
DS-27W-0400	SHINEPRO SCREEN GRIT 400	685mm / 27"	€ 234,00
DS-27W-0600	SHINEPRO SCREEN GRIT 600	685mm / 27"	€ 225,00

SUPRASHINE

advantages



THE MOST COMPLETE & EFFECTIVE RANGE OF PADS FOR FLOOR RESTORATION AND MAINTENANCE

No special equipment needed. Compatible with most low-speed and high-speed floor machines (buffers, autoscrubbers, burnishers, etc). Use with velcro pad holder for best results. No chemicals required. Use only water. Simple and easy process to save you time and money.

FAST RESULTS WITH MINIMUM EFFORT.

Floor maintenance



SUPRASHINE MAINTENANCE

Efficient and versatile. Professional range of pads with flexible material to deep clean, upgrade and maintain all types of coated and uncoated, hard and resilient floors. Offered in all popular sizes from 5" to 28" diameter. Also available in rectangular shapes. **Minimum order 10 pcs of each grit.**

CODE	DESCRIPTION	SIZE	PRICE
SRG-0400-17	SUPRASHINE 400 GRIT, RED	432mm/17"	€ 38,50
SRG-0800-17	SUPRASHINE 800 GRIT, WHITE	432mm/17"	€ 38,50
SRG-1800-17	SUPRASHINE 1800 GRIT, YELLOW	432mm/17"	€ 38,50
SRG-3500-17	SUPRASHINE 3500 GRIT, GREEN	432mm/17"	€ 38,50
SRG-8000-17	SUPRASHINE 8000 GRIT, SILVER	432mm/17"	€ 38,50
SRG-0400-20	SUPRASHINE 400 GRIT, RED	508mm/20"	€ 44,50
SRG-0800-20	SUPRASHINE 800 GRIT, WHITE	508mm/20"	€ 44,50
SRG-1800-20	SUPRASHINE 1800 GRIT, YELLOW	508mm/20"	€ 44,50
SRG-3500-20	SUPRASHINE 3500 GRIT, GREEN	508mm/20"	€ 44,50
SRG-8000-20	SUPRASHINE 8000 GRIT, SILVER	508mm/20"	€ 44,50
SRG-0400-27	SUPRASHINE 400 GRIT, RED	686mm 27"	€ 80,50
SRG-0800-27	SUPRASHINE 800 GRIT, WHITE	686mm 27"	€ 80,50
SRG-1800-27	SUPRASHINE 1800 GRIT, YELLOW	686mm 27"	€ 80,50
SRG-3500-27	SUPRASHINE 3500 GRIT, GREEN	686mm 27"	€ 80,50
SRG-8000-27	SUPRASHINE 8000 GRIT, SILVER	686mm 27"	€ 80,50

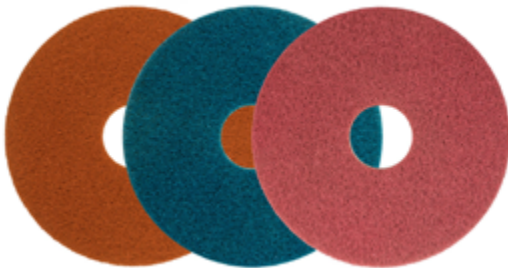

SUPRASHINE HP HIGH PERFORMANCE

A dedicated range of HIGH PERFORMANCE pads with flexible material for daily maintenance of HIGH TRAFFIC floors. Also, use to upgrade any floor during daily maintenance. Offered in all popular sizes from 5" to 28" diameter. Also available in rectangular shapes. **Minimum order 10 pcs of each grit.**

CODE	DESCRIPTION	SIZE	PRICE
SHP-0800-17	SUPRASHINE HP 800 GRIT, ORANGE	432mm/ 17"	€ 53,50
SHP-1800-17	SUPRASHINE HP 1800 GRIT, BLUE	432mm/ 17"	€ 53,50
SHP-3500-17	SUPRASHINE HP 3500 GRIT, PINK	432mm/ 17"	€ 53,50
SHP-0800-20	SUPRASHINE HP 800 GRIT, ORANGE	508mm/ 20"	€ 62,00
SHP-1800-20	SUPRASHINE HP 1800 GRIT, BLUE	508mm/ 20"	€ 62,00
SHP-3500-20	SUPRASHINE HP 3500 GRIT, PINK	508mm/ 20"	€ 62,00
SHP-0800-27	SUPRASHINE HP 800 GRIT, ORANGE	686mm/ 27"	€ 112,50
SHP-1800-27	SUPRASHINE HP 1800 GRIT, BLUE	686mm/ 27"	€ 112,50
SHP-3500-27	SUPRASHINE HP 3500 GRIT, PINK	686mm/ 27"	€ 112,50

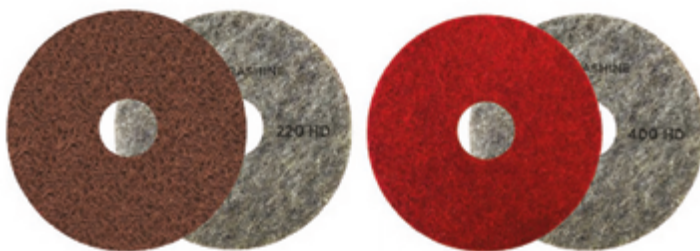

SUPRASHINE HD HEAVY DUTY PADS

SupraShine HD tough material is ideal for surface preparation and chemical-free stripping **with water only**. Offered in all popular sizes from 5" to 28" diameter. Also available in rectangular shapes. **Minimum order 10 pcs of each grit.**

CODE	DESCRIPTION	SIZE	PRICE
SHD-0220-17	SUPRASHINE HD 220 GRIT, BROWN	432mm/ 17"	€ 38,50
SHD-0400-17	SUPRASHINE HD 400 GRIT, RED	432mm/ 17"	€ 38,50
SHD-0220-20	SUPRASHINE HD 220 GRIT, BROWN	508mm/20"	€ 44,50
SHD-0400-20	SUPRASHINE HD 400 GRIT, RED	508mm/20"	€ 44,50
SHD-0220-27	SUPRASHINE HD 220 GRIT, BROWN	686mm/27"	€ 80,50
SHD-0400-27	SUPRASHINE HD 400 GRIT, RED	686mm/27"	€ 80,50

SUPRASHINE HYBRID TOOLS

A complete range of tools from 50 to 400 grit designed to restore surfaces - eliminate stains, scratches and orange peel, and achieve a smooth surface. Suitable for use on concrete, terrazzo and natural stone. Attach the 5-inch Hybrids to a standard pad. **Use with low-speed machines and water only. Minimum order 5 pcs of each grit.**

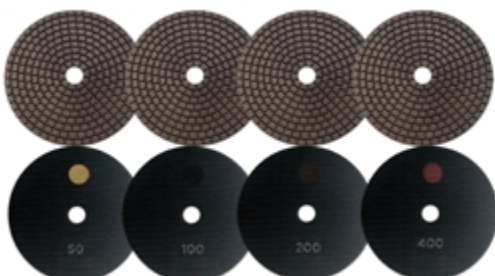

CODE	DESCRIPTION	SIZE	PRICE
SHB-050-5	SUPRASHINE HYBRID 50 GRIT, GOLD	127mm/ 5"	€ 38,50
SHB-100-5	SUPRASHINE HYBRID 100 GRIT, BLACK	127mm/ 5"	€ 38,50
SHB-200-5	SUPRASHINE HYBRID 200 GRIT, BROWN	127mm/ 5"	€ 38,50
SHB-400-5	SUPRASHINE HYBRID 400 GRIT, RED	127mm/ 5"	€ 38,50

Floor maintenance

USING SUPRASHINE WITH **LOW-SPEED MACHINES**

SCRUBBER-DRYER, SINGLE-DISC/BUFFER



Unless it is an extreme case, we recommend the use of only water (without chemicals) to grind, restore, strip, clean, upgrade or maintain all floors.

DAILY MAINTENANCE

Very Soft Coatings
Delicate Surfaces
Highgloss Porcelain



MAX GLOSS

8000

ALL AROUND DAILY MAINTENANCE

Medium / Hard Coatings
Pvc
Vinyl
Rubber
Natural Wood



3500

ALL AROUND DAILY MAINTENANCE

Matt Pvc
Vinyl
Rubber



1800

DEEP CLEANING

PVC
Vinyl
Rubber
Natural Wood
Top Scrub All Coatings



800

VERY DEEP CLEANING

Porous Ceramic Tiles
Matt Porcelain
Granite



400

Restoration:

Epoxy / Resin
Vinyl
Pvc With Damaged Pur

200

100

50

SUPRASHINE HP HIGH PERFORMANCE PADS

DAILY GLOSS UPGRADE & MAINTENANCE VERY HIGH GLOSS

Polished Concrete
Terrazzo, Epoxy (Resin & Terrazzo)
Marble, Granite,
Ceramic Tiles

DAILY GLOSS UPGRADE & MAINTENANCE - HIGH GLOSS

Polished Concrete
Terrazzo, Epoxy (Resin & Terrazzo)
Marble, Granite,
Ceramic Tiles

DAILY GLOSS UPGRADE & MAINTENANCE - LOW GLOSS

Porous Ceramic Tiles
Matt Porcelain

DEEP CLEANING ALL FLOORS

SUPRASHINE HD HEAVY DUTY PADS



PREP, STRIP, HONE

HYBRIDS



RESTORATION

Concrete
Terrazzo
Stone

HONING

GRINDING

USING SUPRASHINE WITH **HI-SPEED MACHINES**

BURNISHER
AS A POWERFUL POLISHING TOOL

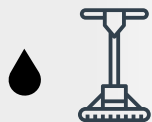

Preferably with slightly wet pads to Eliminate dust, achieve cleaning effect, improve pad life and gloss quality.

DAILY & PERIODIC BURNISHING PAD TO PUMP UP THE GLOSS

All Coated &
Uncoated Floors
Flexible Material



MAX GLOSS

8000

GLOSS UPGRADE LEVEL 3

Uncoated Floors
Flexible Pad Material



3500

GLOSS UPGRADE LEVEL 2

Uncoated Floors
Flexible Pad Material



1800

GLOSS UPGRADE LEVEL 1

Uncoated Floors
Flexible Pad Materials



800

SURFACE PREP

Uncoated Floors
Flexible Pad Material



400

200

SUPRASHINE HP HIGH PERFORMANCE PADS

GLOSS UPGRADE, LEVEL 3

Uncoated Floors
Flexible Material
Faster & Higher Gloss
Longer Lifespan



GLOSS UPGRADE, LEVEL 2

Uncoated Floors
Flexible Material
Faster & Higher Gloss
Longer Lifespan



GLOSS UPGRADE, LEVEL 1

Uncoated Floors
Flexible Material
Faster & Higher Gloss
Longer Lifespan



SUPRASHINE HD HEAVY DUTY PADS

SURFACE PREP, HONING

Uncoated Floors
Heavy-duty Material



TROWEL SHINE



KLINSYSTEM TROWEL SHINE POLISHING SYSTEM

TRANSFORM YOUR POWER TROWEL INTO A PLANETARY GRINDING AND POLISHING MACHINE

The fastest and most cost efficient way to polish Concrete industrial floors

New Klinsystem concrete polishing system with Power trowels suitable for new and old industrial floors with very large sizes where traditional grinding and polishing system is not the best option due to time frame, budget or other constraints.

Klinsytem Trowel Shine system is the fastest and most cost-effective sanding system for industrial cement floors in the world. Klinsytem Trowel Shine system stands out from other systems on the market thanks to the velcro-type drivers with multi-directional flexible joint that rotate allowing a better and faster processing. The system works with water for the first 5 steps using the Waffel grit 50-100-200-400-800 tools.

For the last steps grit 1800 and BUFF the system is completely dry. During polishing steps, the Klinsytem Trowel Shine system requires the use of the Concrete Hardner Lithium (concrete densifier) and the Concrete Guard Lithium (sealer Lithium based). These products are not dangerous for the environment and are used to consolidate, harden and protect the surface.

MAIN BENEFITS

- Incredibly high productivity rates - over 1000 square metres per hour per grit.
- Trowel Shine transforms your power trowel into a planetary grinding and polishing machine to achieve the desired concrete finish.
- Faster system compared to any other traditional polishing system.
- The Trowel Shine tool holders feature rotating head technology and flexible foam for an even tool wear and perfect balance.
- Minimal start-up cost for power trowel owners who want to add polishing to their services.
- No need to buy grinding machine, all you need is just Trowel Shine tool holders and diamond tools.
- Works with walk-behind and ride-on power trowels.
- Fast and easy tool changes thanks to the velcro connection.
- Rotating head technology and flexible foam heads for correct tool wear and balance.





Installation of velcro pad holders on the floating pans

TROWEL SHINE TOOL HOLDERS

Choose between 270mm, 335mm and 356mm tool holders, depending on your power trowel type, floating pans diameter and number of blades. The tool holders come with installation templates and instructions to help you drill the holes correctly.



CODE	DESCRIPTION	PRICE
P02FP10.63	Trowel Shine Velcro Pad Holder 270mm	€ 400,00
P02FP14	Trowel Shine Velcro Pad Holder 356mm	€ 467,00

CODE	DESCRIPTION	PRICE
A80.00.00	Trowel Shine Metal Tool Holder 335mm	€ 688,00

FREE SPINNING HEADS AND FREE PLANETARY DRIVE

FAST AND EASY TOOLS CHANGES WITH LAVINA QUICK CHANGE RINGS

ENCAPSULATED BEARINGS - NO NEED FOR PERIODIC REGREASING OR INSPECTION

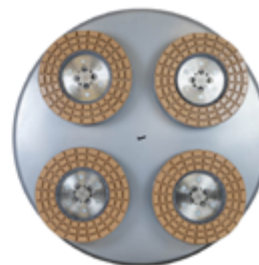
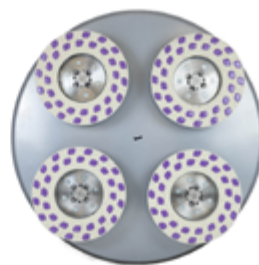
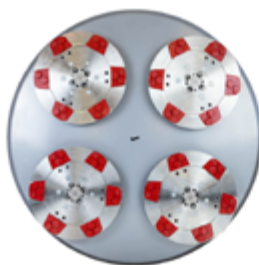

TROWEL SHINE
POWER TROWEL CONCRETE POLISHING SYSTEM



WAFFEL DIAMOND RESIN PADS
GRIT 50 - 100 - 200 - 400 - 800
WET SYSTEM



CONCRETE HARDNER LITHIUM
Concrete Densifier



V-HARR
GRIT 1800
DRY SYSTEM



CONCRETE GUARD LITHIUM
Concrete Sealer



SHINEPRO
GRIT BUFF
DRY SYSTEM

KS 240 GRINDING MACHINE



KS 240 is a single-disc grinder designed for the preparation of small and medium surfaces. KS 240 is very easy to use because it reduces drastically the vibrations to the operator, thanks to the vacuum connection is possible to work without dust.

KS 240 is the perfect machine for the preparation of at surfaces, floor levelling, the preparation of the concrete before painting, removing of coating defects or adhesives, mastic, paints, resins. Repairing of damaged concrete and grinding rough surfaces.



GAC2542 € 85,00 cad.
Diamond insert for standard concrete

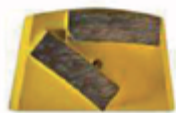

GAC2546 € 85,00 cad.
Diamond insert for ceramic, glue residue and very hard concrete

MADE in ITALY



Folding handle for easy transport and facilitated storage



REMOVABLE LATERAL INLET

to perform the working flush with the wall.



INTEGRATED DUST COLLECTION with rear suction.

Extraction pipe connection with tube supports.

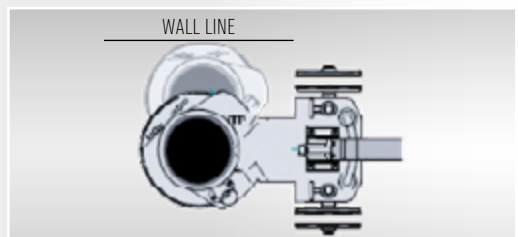

SWIVELLING FRAME

the lateral inlet allow to use the machine as EDGER MACHINE.

KS 240 ESTIMATED PRODUCTION* - Sqm/H

Concrete grinding 1 Step	20 - 25
Terrazzo grinding 5 Step	45 - 47
Glue removal 1 Step	15 - 25
Paint removal 1 Step	10 - 20

*production numbers may vary according to the surface conditions, diamonds used, equipment operator, etc.

TECHNICAL DATA

Power	2,2 Kw - 3 Hp	Tooling system	5 diamond insert
Working Width	240 mm	Tool holder	240mm / 9,5"
Voltage	220 V - 50 Hz	Application	Dry
Weight	55Kg	Dust-vacuum	Yes
Amperage	Max 12 Amp	Speed	1450 rpm
		Price	€ 2.490,00

GRINDEX 350



QUICK CHANGE TOOLING SYSTEM



SWIVELING FRAME SYSTEM



WALL LINE



96KG
Heavy grinding machine



Adjustable handle



Lateral inlet

Integrate dust collecting system

**Powerful 3 kW
4 HP motor**

**Available
220 V or 380 V
with soft start
and variable speed**

GRINDEX 350: powerful single-disc grinder fitted with wide disc 350mm, designed for preparation of Concrete and Natural Stone surfaces. GRINDEX 350 is available in 3 versions: 220 V with variable speed, 380 V fixed speed, 380 V with variable speed. The swiveling frame system and the 2 lateral inlets allow to use the machine also as EDGER MACHINE.

96 Kilos total weight, easy to use, equipped with a special anti-shock system which drastically reduce the vibration to the operator. The integrate dust collecting system allows to work dust free. Quick disassembly of the head from the frame and fast electric disconnection for easy transport. Suitable for repairing and leveling damaged floors, grinding of rough surfaces, preparation of concrete surfaces before resin, removing of different kind of coatings like glue, resin and varnish and more.

Also suitable for bush-hammering, grinding, polishing and fast exposing of aggregates.

GRINDEX 350 PRODUCTIVITY RATES - Sqm/H

Concrete grinding 1Step	40 - 45
Terrazzo grinding 1Step	60 - 85
Glue removal 1Step	30 - 35
Paint removal 1Step	20 - 35

TECHNICAL DATA

Model	Power	Voltage - Frequency	Amperage	Working Width	Tool speed	Tool size	Water tank	Weight	PRICE
GRINDEX 350 380 V	3 kW - 4 HP	380-400 V 50-60 Hz	Max 14 Amp	350mm	700 rpm	Quick change	N/A	96 Kg	€ 2.990,00
GRINDEX 350 VS 220 V	3 kW - 4 HP	220 V 50-60 Hz	Max 14 Amp	350mm	0-700 rpm	Quick change	N/A	96 Kg	€ 3.450,00
GRINDEX 350 VS 380 V	3 kW - 4 HP	380-400 V 50-60 Hz	Max 14 Amp	350mm	0-700 rpm	Quick change	N/A	96 Kg	€ 3.590,00

HG180 VS HAND GRINDER



180 mm

VARIABLE SPEED



EFFICIENT VACUUM HOOD
with replaceable brush and sliding cover



VACUUM COVER WITH SPRING SYSTEM



LED LOAD INDICATOR
allows the operator to work at peak efficiency.

HG180 VS: Hand grinder for corners, edges, countertops, skirtings, stairs and small surfaces. HG180 VS combines power and ease-of-use features for improved performance. It is engineered for smoothing and levelling concrete surface and concrete seams. The constant speed under load allows to complete heavy works. HG180 VS includes the protective Vacuum hood.

MAIN FEATURES

- Variable speed 3200 - 5600 rpm
- LED indicator overload/overheating
- Sliding cover with spring system
- Ergonomic adjustable handle with soft grip
- Powerful motor 2200W
- Anti accidental reboot system
- Vacuum hood with replaceable brush
- Constant speed under load



MAIN TOOLS

EDGE MASTER 5-STEP GRINDING SYSTEM

High performing ceramic bond to refine and blend your edge work faster and more efficiently for concrete floors. Wet and dry use.



Edge Master Ceramic Turbo Cup, M14	Ø 180mm - X Coarse	€ 155,00
Edge Master Ceramic Turbo Cup, M14	Ø 180mm - Coarse	€ 155,00
Edge Master Ceramic Turbo Cup, M14	Ø 180mm - Medium	€ 155,00
Edge Master Ceramic Turbo Cup, M14	Ø 180mm - Fine	€ 155,00
Edge Master Ceramic Turbo Cup, M14	Ø 180mm - X Fine	€ 155,00

TECHNICAL DATA

Power	2200 W (220V)	Tool diameter	180 mm
Variable speed	3200 - 5600 rpm	Weight	5 Kg
Hole	22,23 mm - 7/8"	Connection	M14
Price		€ 1.610,00	

HG125 VS HAND GRINDER



EFFICIENT VACUUM HOOD
with replaceable brush



SLIDING COVER WITH SPRING SYSTEM



ERGONOMIC ADJUSTABLE HANDLE

MAIN FEATURES

- Variable speed 4300 - 7200 rpm
- Powerful motor 2200W
- LED indicator overload/overheating
- Vacuum hood with replaceable brush
- Sliding cover with spring system
- Constant speed under load
- Ergonomic adjustable handle with soft grip
- Anti accidental reboot system

VARIABLE
SPEED



125 mm



HG125 VS: Variable Speed Hand grinder for corners, edges, countertops, skirtings, stairs and small surfaces and for opening the joints. HG125 VS is the ideal machine to achieve a perfect grinding of natural stones, concrete and a perfect polishing of countertops, shelves, tables and narrow areas. It can be used as a edge grinder, as well as a joint chaser thanks to its extra accessories.

HG125 VS includes protective Vacuum hood.

MAIN TOOLS



METAL BOND TURBO CUP

Designed for grinding stone and concrete surfaces.
Offered in: Coarse, Medium and Fine grit.

Turbo Cup, M14	Ø 125mm - Coarse	€ 134,00
Turbo Cup, M14	Ø 125mm - Medium	€ 134,00
Turbo Cup, M14	Ø 125mm - Fine	€ 134,00



EDGE MASTER 5-STEP GRIND SYSTEM

High performing ceramic bond for concrete floors. Wet and dry use.

Edge Master Ceramic, M14	Ø 125mm - X Coarse	€ 134,00
Edge Master Ceramic, M14	Ø 125mm - Coarse	€ 134,00
Edge Master Ceramic, M14	Ø 125mm - Medium	€ 134,00
Edge Master Ceramic, M14	Ø 125mm - Fine	€ 134,00
Edge Master Ceramic, M14	Ø 125mm - X Fine	€ 134,00

TECHNICAL DATA

Power	2200 W (220V)	Tool diameter	125 mm
Variable speed	4300 - 7200 rpm	Weight	4,7 Kg
Hole	22,23 mm - 7/8"	Connection	M14
		Price	€ 1.380,00



Speedy

3 STEP

NEW FASTER & LESS EXPENSIVE POLISHING SYSTEM
CONCRETE - MARBLE - TERRAZZO

STEP 1



STEP 2

STEP 3

READY... SET...
GRIND!



SPEEDY 3 Step

SUITABLE FOR CONCRETE, MARBLE AND TERRAZZO



SPEEDY 3 STEP: new faster and cheaper polishing system developed by Klinsystem. Suitable for Concrete, Marble and Terrazzo. NEW 3 STEP System allows drastic **reduction of grinding and polishing time and costs**. Large increase of productivity preserving **high quality standards**. SPEEDY 3 STEP allows you to get an **excellent level of glossy finish** on any type of floor with **less resources, less effort and in less time**. For optimal processing, we suggest to work with low-speed (450/500 rpm) and additional weight. After STEP 3 as last polishing step, we suggest to use HYPERPAD MAMBA (DRY) at maximum speed to clean the surface and increase the shine.

Ø 3"/75mm



STEP 1

Speedy Step 1 with 3 metal segments inside the tool designed to quickly remove any grouting compounds and at the same time to open the floor, removing slight undulations and deep scratches on the floor. Its hybrid composition and the aggressive metal segments inside the tool allows to cut the surface and prepare the floor for the next step. Can be used Wet or Dry.

Ø 4"/100mm



STEP 1



STEP 2

Speedy Step 2 transitional tool, designed to quickly remove scratches from the previous step and getting the surface smooth with slight satin effect. Its hybrid composition allows to start polishing the surfaces and prepare the floor for the last step. Can be used Wet or Dry.



STEP 2



STEP 3

Speedy Step 3 final step designed to polishing the surface up to grit 800. Its hybrid composition allows to quickly remove any scratches and polishing perfectly the surface. The quality of the finish can be compared to the traditional resin tools grit 800. Can be used Wet or Dry.



STEP 3

MAIN ADVANTAGES:

- Dry and Wet application
- Fast cutting and floor preparation
- High productivity
- Labour cost reduction
- Fast system: only 3 steps
- Easy to use
- Available 3"/75mm and 4"/100mm
- Eco-friendly

DATA SHEET

Suitable for	Concrete / Marble / Terrazzo
Bond	Hybrid
Composition	Natural diamond
Application	Wet & Dry
Connection	Velcro support

DESCRIPTION	SIZE	THICKNESS	PRICE
SPEEDY STEP 1	3"/75mm	12mm	€ 67,50
SPEEDY STEP 2	3"/75mm	12mm	€ 24,50
SPEEDY STEP 3	3"/75mm	12mm	€ 24,50
SPEEDY STEP 1	4"/100mm	12mm	€ 80,00
SPEEDY STEP 2	4"/100mm	12mm	€ 27,50
SPEEDY STEP 3	4"/100mm	12mm	€ 27,50



4 STEP POLISHING SYSTEM

HYBRID FLOOR PADS FOR SOFT AND MEDIUM HARD SURFACES

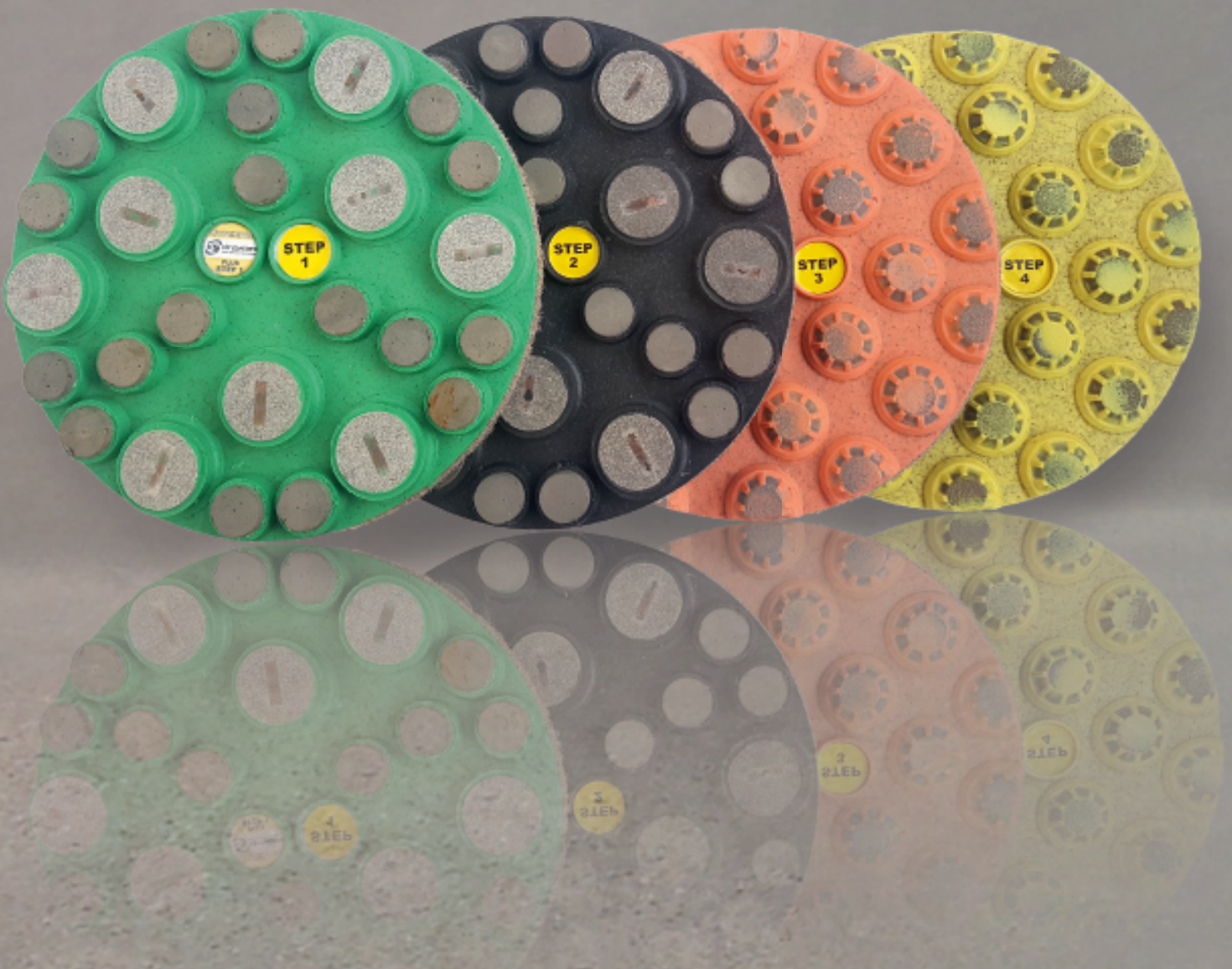

suitable for
CONCRETE, MARBLE AND TERRAZZO

HIGH PERFORMANCE - HIGH CUTTING - NO SCRATCHES

STEP 1

STEP 2

STEP 3

STEP 4

NEW 4 STEP POLISHING SYSTEM

HYBRID FLOOR PADS SUITABLE FOR SOFT AND MEDIUM HARD SURFACES

NEW 4 STEP grinding and polishing system developed by Klinsystem, allows drastic reduction of grinding and polishing time and costs. Suitable for Soft and Abrasive Concrete, Marble and Terrazzo floors. Large increase of productivity preserving high quality standards.

STEP 1 and **STEP 2** Tools with Hybrid METAL and RESIN bond designed for very fast and quick first floor grinding and levelling.

High performance, high cutting and SCRATCHES-FREE grinding also from the first step.

STEP 3 and **STEP 4** Quick polishing process reduced in only 2 steps.

The flexible design allows continuous cutting even on unlevelled floor keeping always long lasting tools life. Easy Quick Tool Change with floor pad connection.

No flaw grinding and no diamond element grazing.

HYPERPAD PLUS 4 STEP allows you to get an excellent level of glossy finish on any type of floor with less resources, with less effort and in less time.

For optimal processing, we suggest to work with low-speed (450/500 rpm) and additional weight. After STEP 4 as last polishing step, we suggest to use HYPERPAD MAMBA (DRY) at maximum speed, to clean the surface and increase the shine.



STEP 1



STEP 1

Suitable for: Soft Concrete / Marble / Terrazzo
Application: Wet & Dry
Tool thickness: 14mm

Bond: Hybrid metal and resin
Composition: Natural diamond
Connection: Floor pad

Size Ø 235mm

with 9 metal segments

€ 175,00



STEP 2



STEP 2

Suitable for: Soft Concrete / Marble / Terrazzo
Application: Wet & Dry
Tool thickness: 14mm

Bond: Hybrid metal and resin
Composition: Natural diamond
Connection: Floor pad

Size Ø 235mm

with 9 metal segments

€ 175,00



STEP 3



STEP 3

Suitable for: Soft Concrete / Marble / Terrazzo
Application: Wet & Dry
Tool thickness: 10mm

Bond: Hybrid resin bond
Composition: Natural diamond
Connection: Floor pad

Size Ø 235mm

without metal segments

€ 109,00



STEP 4



STEP 4

Suitable for: Soft Concrete / Marble / Terrazzo
Application: Wet & Dry
Tool thickness: 10mm

Bond: Hybrid resin bond
Composition: Natural diamond
Connection: Floor pad

Size Ø 235mm

without metal segments

€ 109,00



HYPERPAD

HARD

4 STEP POLISHING SYSTEM

HYBRID FLOOR PADS FOR VERY HARD SURFACES

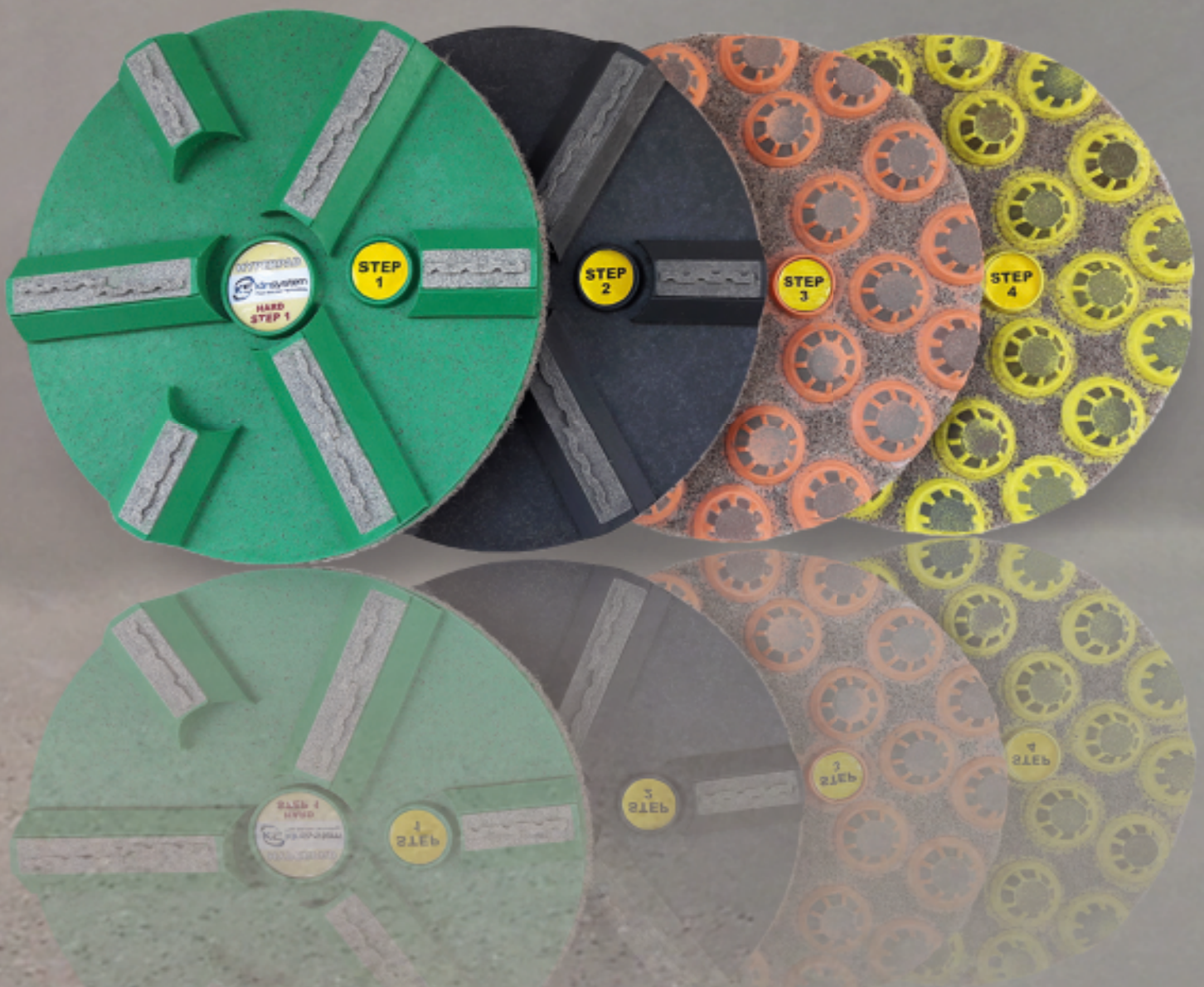

suitable for

HARD CONCRETE, TERRAZZO OVERLAY, GRANITE AND GRES

HIGH PERFORMANCE - HIGH CUTTING - NO SCRATCHES

HYPERPAD Hard



NEW 4 STEP POLISHING SYSTEM HYBRID FLOOR PADS SUITABLE FOR VERY HARD SURFACES

NEW 4 STEP grinding and polishing system developed by Klinsystem which allows drastic reduction of grinding and polishing time and costs. Suitable for Very Hard Concrete, Terrazzo and Micro Terrazzo Overlay, Granite and Gres floors. Large increase of productivity preserving high quality standards.

STEP 1 and **STEP 2** Tools with Hybrid METAL and RESIN bond designed for very fast and quick first floor grinding and levelling.

STEP 3 and **STEP 4** Quick polishing process reduced in only 2 steps. High performance, high cutting and SCRATCHES-FREE grinding also from the first step. The flexible design allows continuous cutting even on unlevelled floor keeping always long lasting tools life. Easy Quick Tool Change with floor pad connection. No flaw grinding and no diamond element glazing.

HYPERPAD HARD 4 STEP allows you to get an excellent level of glossy finish on any type of floor with less resources, with less effort and in less time.

For optimal processing, we suggest to work with low-speed (450/500 rpm) and additional weight. After STEP 4 as last polishing step, we suggest to use HYPERPAD MAMBA (DRY) at maximum speed to clean the surface and increase the shine.

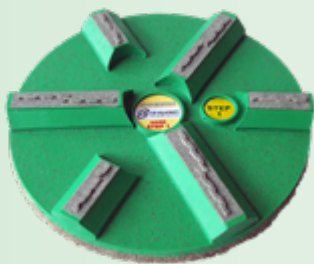

STEP 1



STEP 1

Suitable for: Hard and Very Hard Concrete/
Granite Terrazzo and Micro Terrazzo Overlay
Application: Wet & Dry

Bond: Hybrid metal and resin
Composition: Natural diamond
Connection: Floor pad

Size Ø 235mm

with 6 metal segments

€ 195,00



STEP 2



STEP 2

Suitable for: Hard and Very Hard Concrete/
Granite Terrazzo and Micro Terrazzo Overlay
Application: Wet & Dry

Bond: Hybrid metal and resin
Composition: Natural diamond
Connection: Floor pad

Size Ø 235mm

with 6 metal segments

€ 195,00



STEP 3



STEP 3

Suitable for: Hard and Very Hard Concrete/
Granite Terrazzo and Micro Terrazzo Overlay
Application: Wet & Dry

Bond: Hybrid resin bond
Composition: Natural diamond
Connection: Floor pad

Size Ø 235mm

without metal segments

€ 109,00



STEP 4



STEP 4

Suitable for: Hard and Very Hard Concrete/
Granite Terrazzo and Micro Terrazzo Overlay
Application: Wet & Dry

Bond: Hybrid resin bond
Composition: Natural diamond
Connection: Floor pad

Size Ø 235mm

without metal segments

€ 109,00



HYPERPAD

SELF

4 STEP POLISHING SYSTEM

HYBRID FLOOR PADS FOR HARD SELF-LEVELING OVERLAY



suitable for
SELF-LEVELING OVERLAY LIKE ULTRATOP AND SIMILAR
HIGH PERFORMANCE - HIGH CUTTING - NO SCRATCHES

HYPERPAD Self

STEP 1

STEP 2

STEP 3

STEP 4

NEW 4 STEP POLISHING SYSTEM SUITABLE FOR HARD SELF-LEVELING OVERLAY LIKE ULTRATOP AND SIMILAR

NEW 4 STEP grinding and polishing system developed by Klinsystem which allows drastic reduction of grinding and polishing time and costs. Suitable for extremely Hard Concrete, Hard Self-leveling Overlay like Mapei UltraTop or similar products, Hard Micro Terrazzo and Terrazzo Overlay. Large increase of productivity preserving high quality standards.

STEP 1 and **STEP 2** - Tools designed for very fast and quick first floor grinding and levelling.

STEP 3 and **STEP 4** - Quick polishing process reduced in only 2 steps.

SCRATCHES-FREE, high performance grinding and polishing. The flexible design allows continuous cutting even on unlevelled floor keeping always long lasting tools life. Easy Quick Tool Change with floor pad connection. No flaw grinding and no diamond element glazing.

HYPERPAD SELF allows you to get an excellent level of glossy finish on extremely Hard Concrete, Hard Self-leveling Overlay like Mapei UltraTop or similar products, Hard Terrazzo and Micro Terrazzo Overlay with less resources, with less effort and in less time.

For optimal processing, we suggest to work with low-speed (450/500 rpm) and additional weight. After STEP 4 as last polishing step, we suggest to use HYPERPAD MAMBA (dry) at maximum speed to clean the surface and increase the shine.



DATA SHEET

Suitable for	Concrete Screeds / Hard Self-leveling Overlay
Bond	Hybrid resin bond
Composition	Natural diamond
Application	Wet & Dry
Connection	Floor pad

DESCRIPTION

SIZE

PRICE

HYPERPAD SELF Step 1	235mm	€ 109,00
HYPERPAD SELF Step 2	235mm	€ 109,00
HYPERPAD SELF Step 3	235mm	€ 109,00
HYPERPAD SELF Step 4	235mm	€ 109,00

HYPERPAD Mamba

HIGH GLOSS POLISHING PAD WITH NATURAL DIAMOND

HYPERPAD MAMBA polishing pad developed by Klinsystem, thanks to its composition with a combination of Natural Diamonds grits 1500 and 3500, allows to clean and polishing the surface getting an extraordinary ultra gloss finish. Suitable for all kind of polished floors like Concrete, Marble, Granite and Self-leveling Overlay. Also suitable to remove resin diamond tool marks.

Large increase of productivity preserving high quality standards. Its flexible design allows continuous polishing even on unlevelled floors. High performance and long lasting polishing pad, allows to get high glossy finish with less effort and in less time.

For optimal processing with your planetary grinding machine, we suggest to use MAMBA after SPEEDY STEP 3 or HYPERPAD STEP 4 as last polishing step, DRY use at maximum speed to clean the surface and increase the shine.

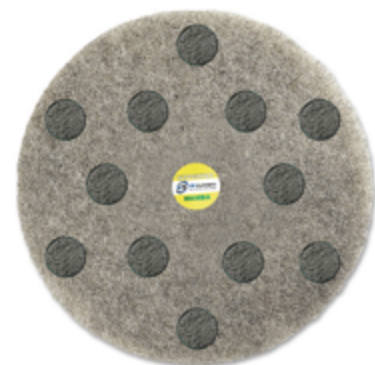

DATA SHEET

Suitable for	All kind of concrete
Bond	Hybrid resin bond grit 1500/3500
Composition	Natural diamond
Application	Dry
Connection	Floor pad

DESCRIPTION

SIZE

PRICE

HYPERPAD MAMBA	235mm	€ 60,00
----------------	-------	---------

Hard Concrete POLISHING SYSTEM

HARD CONCRETE IS A CONCRETE FLOOR POLISHING SYSTEM CREATED AND DEVELOPED BY THE COMPANY KLINSYSTEM.

Thanks to this new system now possible to transform your ordinary concrete floor into a new floor, decorative, not dust, nice to see, polished like mirror protected and very easy to clean and to maintain!

The HARD CONCRETE POLISHING SYSTEM is a MECHANICAL grinding and polishing system with no dangerous chemicals without application of wax or resin.

WHAT IS HARD CONCRETE SYSTEM? With HARD CONCRETE SYSTEM even an old, stained and worn floor can be treated to make it look like new, extremely resistant, no dust, repellent to dirt, and very easy to clean. Transform your concrete floor in a beautiful surface like marble or granite looking which is strong as concrete. Floor will be shine, oil repellent and waterproof and is also possible coloring the surface and create logos.



THE BEST OPTION AND THE BEST SOLUTION

- No dust, but allows to transpire the concrete slab
- Aesthetically comparable as marble or terrazzo flooring
- 5 times more resistant to wear than a standard concrete floor
- 5 times more resistant to traffic of forklifts (no scratches on the floor)
- More economic than any other traditional flooring with greater performance

HARD CONCRETE COLOR SYSTEM

- Available in wide variety of colors and designs
- Versatility of the system
- High gloss finish
- Design Aesthetics



MAIN ADVANTAGES

All resin surfaces have a low wear resistance and a very limited life. The concrete floor treated with HARD CONCRETE SYSTEM has no time limit, after the treatment lasts forever.

Thanks to this innovative system, you can turn any Industrial concrete floor into a modern mirror polished floor, that does not make dust, protected against water, oil and acid, traffic Wear resistant, hygienic, and beautiful to look like terrazzo floor. The concrete polishing system brings exceptional benefits. The maintenance of an old industrial floor during the years is considerably expensive. Grinding and polishing the industrial concrete floor makes it much more resistant to scratches and forklift traffic. The tires will not leave marks thanks to an excellent grip that makes the anti-slip floor.

These results are possible thanks to the use of consolidating products that increase the hardness of the cement by penetrating the floor and becoming part of it eliminating the problem of film formation.

HARD CONCRETE SYSTEM is ideal for all industrial concrete flooring, domestic structures, commercial structures and heavy traffic industrial flooring. The characteristics of HARD CONCRETE makes this system BEST than many other conventional systems such as resins, paints or waxes.



Hard Concrete POLISHING SYSTEM



BENEFITS OF HARD CONCRETE

HARD CONCRETE SYSTEM is great for small and large commercial environments with a wide range of different finishes. Hard Concrete System is a multi-step process, so you can choose the level of finish and the final effective cost.

- Elimination of height variances (Undulations)
- Consolidation of concrete with special chemicals eco-friendly
- The floor become 5 timer harder and resistant to the traffic of heavy trolley and vehicles
- Process of reaction & reparation to remove inherent defects
- Honing to provide uniform & polished finish
- High Protection with Nano Technology
- NO DUST / NO STAIN
- Obtaining of high gloss finish, shine, brilliance
- Water, Acid and Oil repellent

MAIN FEATURES

- **NO DUST:** it doesn't produce dust, dirt, allergens. Resistant to moisture transmission problems: It allows the floor to breathe and eliminates problems arise with other flooring materials that seal the concrete, such as tile, resin etc.
- **LOW MAINTENANCE:** extremely low maintenance, convenient, allows you to create an eco-friendly work environment for employees.
- **NO FORKLIFT TRUCK SIGNS:** The smooth, polished surface resists the signs of forklift tires and protects against oil spills and chemical spills.
- **ECONOMIC AND COST SAVINGS** (no additional coatings) traditional flooring materials such as resins and waxes are not necessary where the concrete slab is used directly as the finished floor surface.
- **DURATION:** highly resistant to trampling and heavy industrial machinery traffic. Much more resistant to stains.
- **ECO-FRIENDLY:** sustainable flooring alternative. It requires no hazardous coatings, detergents and adhesives.
- **HIGH LIGHT REFRACTION:** The polished concrete surface reflects the light. Important for offices, buildings, stores, deposits of materials, big shopping areas, hotels hall, restaurants, public facilities that want to project a professional bright and clean image.
- **SAVING ELECTRICITY:** reducing artificial lighting use, especially in large areas.



CONSOLIDATION AND HARDENING

The concrete floor, treated with silicates has similar characteristics to a granite floor and can be subjected to similar grinding procedures. After the treatment, the concrete floor can be grinded until becoming mechanically polished. Polished concrete is not the result of applying a polishing product but a professional process of grinding and polishing. Polishing concrete with the HARD Concrete system means transforming your industrial floor forever.

APPLICATIONS

- It can be used for public projects, universities, schools, hospitals, stadiums etc.
- Increases the hardness and the resistance to the abrasion of your concrete floor
- Stain-resistant, oil and water-repellent
- Definitely Block the dust from concrete slab
- Extremely economic for big projects, for commercial and industrial areas
- It requires very low maintenance - Ecological (V.O.C. FREE)
- Allow the floor to breathe to prevent peeling
- It lasts 10 times longer than any resin floor



Hard Concrete POLISHING SYSTEM



HARD CONCRETE PRIME

Developed by Klinsystem and suitable for both residential and industrial surfaces. Full step high quality floor grinding and polishing system without exposing the aggregate, includes cracks and holes repairing, high planarity, deep gloss polishing, stain resistant, oil protection and water repellent, modern look, wide range of colours available.

HARD CONCRETE 4 STEP

The fastest way to turn a normal concrete floor, into a new shiny, hard and resistant surface. The latest hybrid technology for concrete grinding and polishing to achieve the best results while saving time, effort and money. Klinsystem provides a wide range of hybrid tools like speedy 3 step and hyperpad 4 STEP.

The hybrid technology allows to save time and money always getting the best quality finish.

HARD CONCRETE TERRAZZO

Deep grinding and polishing system with full exposure of aggregates, high planarity and regularity of the floor.

Includes cracks and holes repairing, high planarity, deep gloss polishing, stain resistant, oil protection and water repellent. Hard Concrete Terrazzo offers a wide variety of colour options and contemporary look.

Suitable for both residential and industrial floors.

TROWEL SHINE SYSTEM

With the new Klinsystem Polishing System is possible to polish up to 2000 square meters per day! Using the power-trowel and the new Klinsystem diamond tools, is now possible turn an industrial floated floor into a beautiful surface, durable, stain-resistant, glossy and easy-to-clean floor.

Suitable for big industrial or commercial areas.

More information pag. 36-37.

Hard Concrete POLISHING SYSTEM



Transform your floor into an indestructible and durable surface suitable for any use. The HARD CONCRETE system developed by Klinsystem transforms your ordinary concrete into a mirror-polished concrete floor, protected, no-scratch, no-dust, stain resistant and easy-to-clean.

The procedure to transform the concrete floor sometimes includes to remove old resin or old coatings from the floor using specific diamond tools. Then is possible to grinding the concrete floor with several steps until the surface become smooth and flat. During the process is important the consolidation of the surface using specific Klinsystem products as **Concrete Hardner** and **Concrete Hardner Lithium**. Then finally is possible to obtain an optimal closure of the porosity of the floor.

The surface become up to 8 times harder and resistant to the abrasion. Once the surface has been polished, is possible to treat the floor with water and oil repellent products as **Concrete Guard Lithium** and **Concrete Gloss**, in order to increase the resistance of the concrete and make it dust proof - water proof and oil repellent. The whole process allows to obtain a glossy surface which is at the same time no-slip and resistant to external agents and heavy traffic.



Coating Removal

PROFESSIONAL QUICK CHANGE TOOLS RANGE suitable for all floor grinders on the market

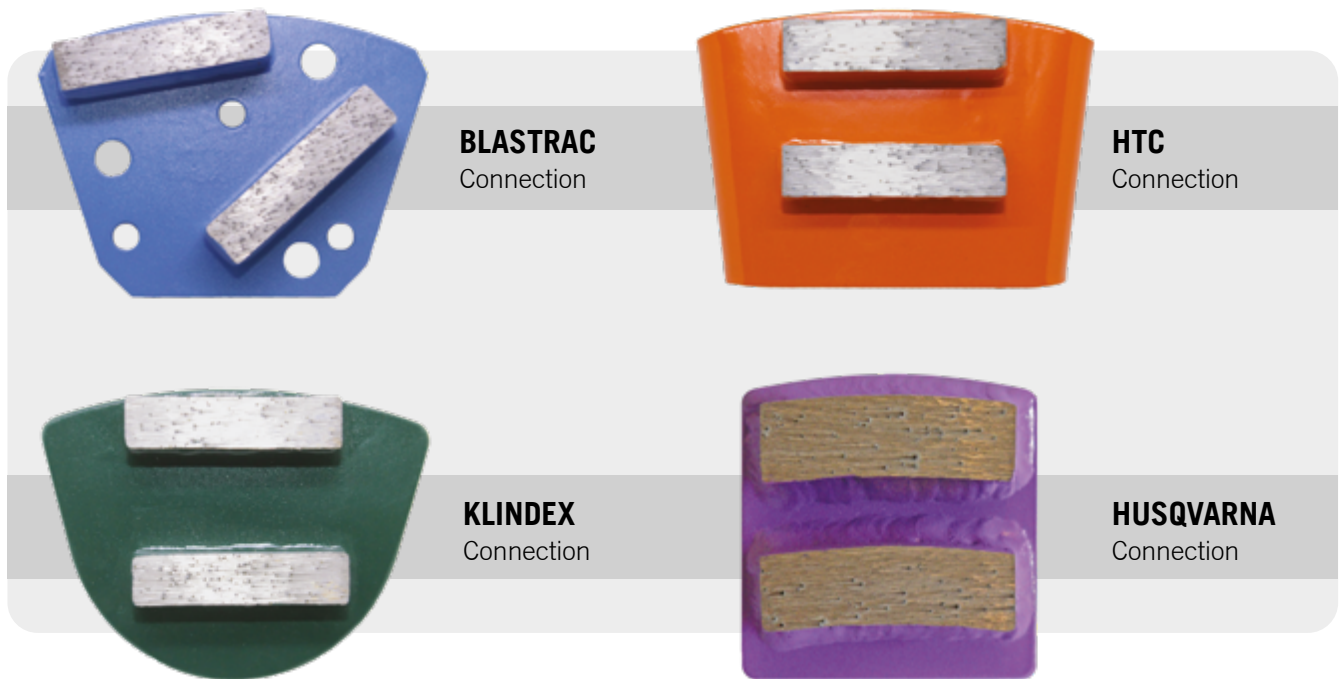

CAX METAL BOND DIAMOND TOOLS FOR VERY ABRASIVE CONCRETE

Suitable for floor preparation, floor levelling and coating removal

	DESCRIPTION					PRICE
	KS CAX00	GRIT 14/24	trapezoid	2 segments	Quick Change	€ 69,00
	KS CAX0	GRIT 36/40	trapezoid	2 segments	Quick Change	€ 66,00
	KS CAX1	GRIT 70/80	trapezoid	2 segments	Quick Change	€ 66,00
	KS CAX2	GRIT 120	trapezoid	2 segments	Quick Change	€ 66,00
	KS CAX00	GRIT 14/24	trapezoid	1 segment	Quick Change	€ 49,00
	KS CAX0	GRIT 36/40	trapezoid	1 segment	Quick Change	€ 45,00
	KS CAX1	GRIT 70/80	trapezoid	1 segment	Quick Change	€ 45,00
	KS CAX2	GRIT 120	trapezoid	1 segment	Quick Change	€ 45,00

CA METAL BOND DIAMOND TOOLS FOR ABRASIVE CONCRETE

Suitable for floor preparation, floor levelling and coating removal

	DESCRIPTION					PRICE
	KS CA00	GRIT 14/24	trapezoid	2 segments	Quick Change	€ 69,00
	KS CA0	GRIT 36/40	trapezoid	2 segments	Quick Change	€ 66,00
	KS CA1	GRIT 70/80	trapezoid	2 segments	Quick Change	€ 66,00
	KS CA2	GRIT 120	trapezoid	2 segments	Quick Change	€ 66,00
	KS CA00	GRIT 14/24	trapezoid	1 segment	Quick Change	€ 49,00
	KS CA0	GRIT 36/40	trapezoid	1 segment	Quick Change	€ 45,00
	KS CA1	GRIT 70/80	trapezoid	1 segment	Quick Change	€ 45,00
	KS CA2	GRIT 120	trapezoid	1 segment	Quick Change	€ 45,00

Coating Removal

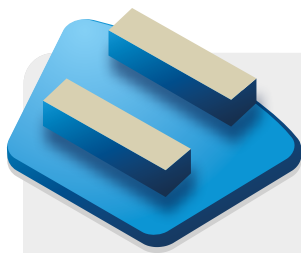

00 BLUE
Extra Coarse

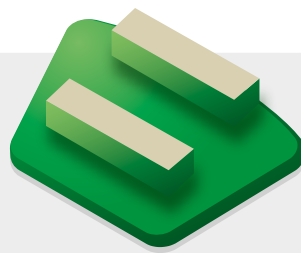

0 GREEN
Coarse

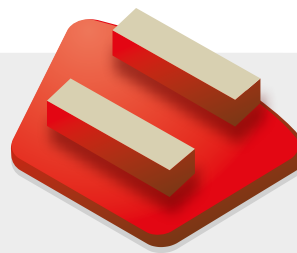

1 RED
Medium

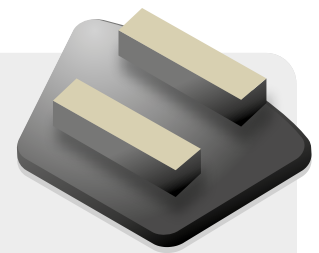

2 BLACK
Fine

CS

METAL BOND DIAMOND TOOLS FOR STANDARD CONCRETE

Suitable for floor preparation, floor levelling and coating removal

DESCRIPTION						PRICE
	KS CS00	GRIT 14/24	trapezoid	2 segments	Quick Change	€ 69,00
	KS CS0	GRIT 36/40	trapezoid	2 segments	Quick Change	€ 66,00
	KS CS1	GRIT 70/80	trapezoid	2 segments	Quick Change	€ 66,00
	KS CS2	GRIT 120	trapezoid	2 segments	Quick Change	€ 66,00
	KS CS00	GRIT 14/24	trapezoid	1 segment	Quick Change	€ 49,00
	KS CS0	GRIT 36/40	trapezoid	1 segment	Quick Change	€ 45,00
	KS CS1	GRIT 70/80	trapezoid	1 segment	Quick Change	€ 45,00
	KS CS2	GRIT 120	trapezoid	1 segment	Quick Change	€ 45,00

CD

METAL BOND DIAMOND TOOLS FOR HARD CONCRETE

Suitable for floor preparation, floor levelling and coating removal

DESCRIPTION						PRICE
	KS CD00	GRIT 14/24	trapezoid	2 segments	Quick Change	€ 69,00
	KS CD0	GRIT 36/40	trapezoid	2 segments	Quick Change	€ 66,00
	KS CD1	GRIT 70/80	trapezoid	2 segments	Quick Change	€ 66,00
	KS CD2	GRIT 120	trapezoid	2 segments	Quick Change	€ 66,00
	KS CD00	GRIT 14/24	trapezoid	1 segment	Quick Change	€ 49,00
	KS CD0	GRIT 36/40	trapezoid	1 segment	Quick Change	€ 45,00
	KS CD1	GRIT 70/80	trapezoid	1 segment	Quick Change	€ 45,00
	KS CD2	GRIT 120	trapezoid	1 segment	Quick Change	€ 45,00

CDX

METAL BOND DIAMOND TOOLS FOR EXTRA HARD CONCRETE

Suitable for floor preparation, floor levelling and coating removal





DESCRIPTION						PRICE
	KS CDX00	GRIT 14/24	trapezoid	2 segments	Quick Change	€ 69,00
	KS CDX0	GRIT 36/40	trapezoid	2 segments	Quick Change	€ 66,00
	KS CDX1	GRIT 70/80	trapezoid	2 segments	Quick Change	€ 66,00
	KS CDX2	GRIT 120	trapezoid	2 segments	Quick Change	€ 66,00
	KS CDX00	GRIT 14/24	trapezoid	1 segment	Quick Change	€ 49,00
	KS CDX0	GRIT 36/40	trapezoid	1 segment	Quick Change	€ 45,00
	KS CDX1	GRIT 70/80	trapezoid	1 segment	Quick Change	€ 45,00
	KS CDX2	GRIT 120	trapezoid	1 segment	Quick Change	€ 45,00

Floor Preparation

KS DA

METAL BOND DIAMOND TOOLS FOR MEDIUM ABRASIVE CONCRETE



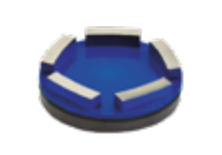

Suitable for floor preparation, coating removal, floor levelling and floor grinding and polishing

	DESCRIPTION					PRICE
	KS DA00	GRIT 24	Ø 240mm - 9,5"	12 segments	Quick Change	€ 270,00
	KS DA0	GRIT 36	Ø 240mm - 9,5"	12 segments	Quick Change	€ 190,00
	KS DA1	GRIT 60	Ø 240mm - 9,5"	12 segments	Quick Change	€ 190,00
	KS DA2	GRIT 120	Ø 240mm - 9,5"	12 segments	Quick Change	€ 190,00
	KS DA00	GRIT 24	Ø 240mm - 9,5"	6 segments	Quick Change	€ 164,00
	KS DA0	GRIT 36	Ø 240mm - 9,5"	6 segments	Quick Change	€ 134,00
	KS DA1	GRIT 60	Ø 240mm - 9,5"	6 segments	Quick Change	€ 134,00
	KS DA2	GRIT 120	Ø 240mm - 9,5"	6 segments	Quick Change	€ 134,00
	KS DA00	GRIT 24	Ø 200mm - 8"	6 segments	Quick Change	€ 161,00
	KS DA0	GRIT 36	Ø 200mm - 8"	6 segments	Quick Change	€ 125,00
	KS DA1	GRIT 60	Ø 200mm - 8"	6 segments	Quick Change	€ 125,00
	KS DA2	GRIT 120	Ø 200mm - 8"	6 segments	Quick Change	€ 125,00
	KS DA00	GRIT 24	Ø 140mm - 5,5"	5 segments	Plastic Support	€ 128,00
	KS DA0	GRIT 36	Ø 140mm - 5,5"	5 segments	Plastic Support	€ 118,00
	KS DA1	GRIT 60	Ø 140mm - 5,5"	5 segments	Plastic Support	€ 118,00
	KS DA2	GRIT 120	Ø 140mm - 5,5"	5 segments	Plastic Support	€ 118,00
	KS DA00	GRIT 24	Ø 100mm - 4"	5 segments	Plastic Support	€ 124,00
	KS DA0	GRIT 36	Ø 100mm - 4"	5 segments	Plastic Support	€ 115,00
	KS DA1	GRIT 60	Ø 100mm - 4"	5 segments	Plastic Support	€ 115,00
	KS DA2	GRIT 120	Ø 100mm - 4"	5 segments	Plastic Support	€ 115,00

KS CD

METAL BOND DIAMOND TOOLS FOR HARD CONCRETE







Suitable for floor preparation, coating removal, floor levelling and concrete grinding and polishing

	DESCRIPTION					PRICE
	KS CD00	GRIT 24	Ø 240mm - 9,5"	6 segments	Quick Change	€ 170,00
	KS CD0	GRIT 36	Ø 240mm - 9,5"	6 segments	Quick Change	€ 150,00
	KS CD1	GRIT 60	Ø 240mm - 9,5"	6 segments	Quick Change	€ 140,00
	KS CD2	GRIT 120	Ø 240mm - 9,5"	6 segments	Quick Change	€ 140,00
	KS CD00	GRIT 24	Ø 240mm - 9,5"	4 segments	Quick Change	€ 140,00
	KS CD0	GRIT 36	Ø 240mm - 9,5"	4 segments	Quick Change	€ 125,00
	KS CD1	GRIT 60	Ø 240mm - 9,5"	4 segments	Quick Change	€ 125,00
	KS CD2	GRIT 120	Ø 240mm - 9,5"	4 segments	Quick Change	€ 125,00
	KS CD00	GRIT 24	Ø 200mm - 8"	4 segments	Quick Change	€ 140,00
	KS CD0	GRIT 36	Ø 200mm - 8"	4 segments	Quick Change	€ 125,00
	KS CD1	GRIT 60	Ø 200mm - 8"	4 segments	Quick Change	€ 115,00
	KS CD2	GRIT 120	Ø 200mm - 8"	4 segments	Quick Change	€ 115,00
	KS CD00	GRIT 24	Ø 140mm - 5,5"	4 segments	Plastic Support	€ 115,00
	KS CD0	GRIT 36	Ø 140mm - 5,5"	4 segments	Plastic Support	€ 95,00
	KS CD1	GRIT 60	Ø 140mm - 5,5"	4 segments	Plastic Support	€ 95,00
	KS CD2	GRIT 120	Ø 140mm - 5,5"	4 segments	Plastic Support	€ 95,00
	KS CD00	GRIT 24	Ø 100mm - 4"	4 segments	Plastic Support	€ 105,00
	KS CD0	GRIT 36	Ø 100mm - 4"	4 segments	Plastic Support	€ 95,00
	KS CD1	GRIT 60	Ø 100mm - 4"	4 segments	Plastic Support	€ 90,00
	KS CD2	GRIT 120	Ø 100mm - 4"	4 segments	Plastic Support	€ 90,00

KS CA

METAL BOND DIAMOND TOOLS FOR ABRASIVE CONCRETE

Suitable for floor preparation, coating removal, floor levelling and floor grinding and polishing

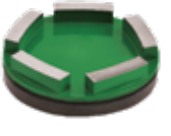
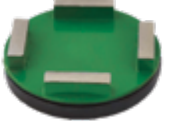
	DESCRIPTION					PRICE
	KS CA00	GRIT 24	Ø 240mm - 9,5"	12 segments	Quick Change	€ 305,00
	KS CA0	GRIT 36	Ø 240mm - 9,5"	12 segments	Quick Change	€ 285,00
	KS CA1	GRIT 60	Ø 240mm - 9,5"	12 segments	Quick Change	€ 265,00
	KS CA2	GRIT 120	Ø 240mm - 9,5"	12 segments	Quick Change	€ 265,00
	KS CA00	GRIT 24	Ø 240mm - 9,5"	6 segments	Quick Change	€ 201,50
	KS CA0	GRIT 36	Ø 240mm - 9,5"	6 segments	Quick Change	€ 184,50
	KS CA1	GRIT 60	Ø 240mm - 9,5"	6 segments	Quick Change	€ 172,00
	KS CA2	GRIT 120	Ø 240mm - 9,5"	6 segments	Quick Change	€ 155,50
	KS CA00	GRIT 24	Ø 200mm - 8"	6 segments	Quick Change	€ 185,00
	KS CA0	GRIT 36	Ø 200mm - 8"	6 segments	Quick Change	€ 176,00
	KS CA1	GRIT 60	Ø 200mm - 8"	6 segments	Quick Change	€ 166,00
	KS CA2	GRIT 120	Ø 200mm - 8"	6 segments	Quick Change	€ 160,00
	KSCA00	GRIT 24	Ø 200mm - 8"	4 segments	Quick Change	€ 148,00
	KSCA0	GRIT 36	Ø 200mm - 8"	4 segments	Quick Change	€ 142,00
	KSCA1	GRIT 60	Ø 200mm - 8"	4 segments	Quick Change	€ 140,00
	KSCA2	GRIT 120	Ø 200mm - 8"	4 segments	Quick Change	€ 135,00
	KS CA00	GRIT 24	Ø 140mm - 5,5"	5 segments	Plastic Support	€ 149,50
	KS CA0	GRIT 36	Ø 140mm - 5,5"	5 segments	Plastic Support	€ 139,00
	KS CA1	GRIT 60	Ø 140mm - 5,5"	5 segments	Plastic Support	€ 129,00
	KS CA2	GRIT 120	Ø 140mm - 5,5"	5 segments	Plastic Support	€ 129,00
	KS CA00	GRIT 24	Ø 140mm - 5,5"	4 segments	Plastic Support	€ 130,00
	KS CA0	GRIT 36	Ø 140mm - 5,5"	4 segments	Plastic Support	€ 120,00
	KS CA1	GRIT 60	Ø 140mm - 5,5"	4 segments	Plastic Support	€ 110,00
	KS CA2	GRIT 120	Ø 140mm - 5,5"	4 segments	Plastic Support	€ 105,00
	KS CA00	GRIT 24	Ø 100mm - 4"	5 segments	Plastic Support	€ 143,00
	KS CA0	GRIT 36	Ø 100mm - 4"	5 segments	Plastic Support	€ 133,50
	KS CA1	GRIT 60	Ø 100mm - 4"	5 segments	Plastic Support	€ 129,00
	KS CA2	GRIT 120	Ø 100mm - 4"	5 segments	Plastic Support	€ 129,00
	KS CA00	GRIT 24	Ø 100mm - 4"	4 segments	Plastic Support	€ 122,00
	KS CA0	GRIT 36	Ø 100mm - 4"	4 segments	Plastic Support	€ 115,00
	KS CA1	GRIT 60	Ø 100mm - 4"	4 segments	Plastic Support	€ 98,00
	KS CA2	GRIT 120	Ø 100mm - 4"	4 segments	Plastic Support	€ 98,00



Floor Preparation

KS CAX

METAL BOND DIAMOND TOOLS FOR VERY ABRASIVE CONCRETE

Suitable for floor preparation, floor levelling and coating removal

	DESCRIPTION					PRICE
	KS CAX00	GRIT 24	Ø 240mm - 9,5"	12 segments	Quick Change	€ 355,00
	KS CAX0	GRIT 36	Ø 240mm - 9,5"	12 segments	Quick Change	€ 320,00
	KS CAX00	GRIT 24	Ø 240mm - 9,5"	6 segments	Quick Change	€ 216,00
	KS CAX0	GRIT 36	Ø 240mm - 9,5"	6 segments	Quick Change	€ 197,00
	KS CAX00	GRIT 24	Ø 200mm - 8"	6 segments	Quick Change	€ 206,00
	KS CAX0	GRIT 36	Ø 200mm - 8"	6 segments	Quick Change	€ 188,00
	KS CAX00	GRIT 24	Ø 200mm - 8"	4 segments	Quick Change	€ 160,00
	KS CAX0	GRIT 36	Ø 200mm - 8"	4 segments	Quick Change	€ 149,00
	KS CAX00	GRIT 24	Ø 140mm - 5,5"	5 segments	Plastic Support	€ 164,00
	KS CAX0	GRIT 36	Ø 140mm - 5,5"	5 segments	Plastic Support	€ 154,00
	KS CAX00	GRIT 24	Ø 140mm - 5,5"	4 segments	Plastic Support	€ 142,00
	KS CAX0	GRIT 36	Ø 140mm - 5,5"	4 segments	Plastic Support	€ 132,00
	KS CAX00	GRIT 24	Ø 100mm - 4"	5 segments	Plastic Support	€ 145,00
	KS CAX0	GRIT 36	Ø 100mm - 4"	5 segments	Plastic Support	€ 136,00
	KS CAX00	GRIT 24	Ø 100mm - 4"	4 segments	Plastic Support	€ 136,00
	KS CAX0	GRIT 36	Ø 100mm - 4"	4 segments	Plastic Support	€ 126,00







Floor Preparation

KS BT

METAL BOND DIAMOND TOOLS WITH ROUND SEGMENTS

Suitable for concrete grinding and to remove resin coating and glue





	DESCRIPTION					PRICE
	KS BT00	GRIT 24	Ø 240mm - 9,5"	6 segments	Quick Change	€ 151,00
	KS BT0	GRIT 36	Ø 240mm - 9,5"	6 segments	Quick Change	€ 151,00
	KS BT00	GRIT 24	Ø 200mm - 8"	5 segments	Quick Change	€ 136,00
	KS BT0	GRIT 36	Ø 200mm - 8"	5 segments	Quick Change	€ 136,00
	KS BT00	GRIT 24	Ø 140mm - 5,5"	4 segments	Plastic Support	€ 105,00
	KS BT0	GRIT 36	Ø 140mm - 5,5"	4 segments	Plastic Support	€ 105,00
	KS BT00	GRIT 24	Ø 100mm - 4"	4 segments	Plastic Support	€ 100,00
	KS BT0	GRIT 36	Ø 100mm - 4"	4 segments	Plastic Support	€ 100,00

KS TCD

METAL BOND DIAMOND TOOLS FOR VERY ABRASIVE CONCRETE

Suitable for floor preparation, floor levelling and coating removal

Very hard bond with special diamond for fast and durable grinding on soft and abrasive concrete

	DESCRIPTION					PRICE
	KS TCD000	GRIT 24	Ø 240mm - 9,5"	6 segments	Quick Change	€ 227,00
	KS TCD00	GRIT 36	Ø 240mm - 9,5"	6 segments	Quick Change	€ 215,00
	KS TCD0	GRIT 60	Ø 240mm - 9,5"	6 segments	Quick Change	€ 155,00
	KS TCD000	GRIT 24	Ø 200mm - 8"	6 segments	Quick Change	€ 218,00
	KS TCD00	GRIT 36	Ø 200mm - 8"	6 segments	Quick Change	€ 205,00
	KS TCD0	GRIT 60	Ø 200mm - 8"	6 segments	Quick Change	€ 148,00
	KS TCD000	GRIT 24	Ø 140mm - 5,5"	5 segments	Plastic Support	€ 180,00
	KS TCD00	GRIT 36	Ø 140mm - 5,5"	5 segments	Plastic Support	€ 167,00
	KS TCD0	GRIT 60	Ø 140mm - 5,5"	5 segments	Plastic Support	€ 119,00
	KS TCD000	GRIT 24	Ø 100mm - 4"	4 segments	Plastic Support	€ 148,00
	KS TCD00	GRIT 36	Ø 100mm - 4"	4 segments	Plastic Support	€ 132,00
	KS TCD0	GRIT 60	Ø 100mm - 4"	4 segments	Plastic Support	€ 98,00

Polished Concrete System

RESIN BOND DIAMOND TOOLS

For Polishing Concrete System suitable for any kind of industrial concrete floors





DESCRIPTION					PRICE
	JUMPFLEX CONCRETE 3	GRIT 60	Ø 75mm – 3"	Velcro connection	€ 18,50
	JUMPFLEX CONCRETE 4	GRIT 120	Ø 75mm – 3"	Velcro connection	€ 18,50
	JUMPFLEX CONCRETE 5	GRIT 220	Ø 75mm – 3"	Velcro connection	€ 18,50
	JUMPFLEX CONCRETE 6	GRIT 400	Ø 75mm – 3"	Velcro connection	€ 18,50
	JUMPFLEX CONCRETE 7	GRIT 800	Ø 75mm – 3"	Velcro connection	€ 18,50
	JUMPFLEX CONCRETE 8	GRIT 1800	Ø 75mm – 3"	Velcro connection	€ 18,50
	JUMPFLEX CONCRETE 3	GRIT 60	Ø 100mm – 4"	Velcro connection	€ 28,50
	JUMPFLEX CONCRETE 4	GRIT 120	Ø 100mm – 4"	Velcro connection	€ 28,50
	JUMPFLEX CONCRETE 5	GRIT 220	Ø 100mm – 4"	Velcro connection	€ 28,50
	JUMPFLEX CONCRETE 6	GRIT 400	Ø 100mm – 4"	Velcro connection	€ 28,50
	JUMPFLEX CONCRETE 7	GRIT 800	Ø 100mm – 4"	Velcro connection	€ 28,50
	JUMPFLEX CONCRETE 8	GRIT 1800	Ø 100mm – 4"	Velcro connection	€ 28,50
	CONDOR CONCRETE 3	GRIT 60	Ø 75mm – 3"	Velcro connection	€ 15,00
	CONDOR CONCRETE 4	GRIT 120	Ø 75mm – 3"	Velcro connection	€ 15,00
	CONDOR CONCRETE 5	GRIT 220	Ø 75mm – 3"	Velcro connection	€ 15,00
	CONDOR CONCRETE 6	GRIT 400	Ø 75mm – 3"	Velcro connection	€ 15,00
	CONDOR CONCRETE 7	GRIT 800	Ø 75mm – 3"	Velcro connection	€ 15,00
	CONDOR CONCRETE 8	GRIT 1800	Ø 75mm – 3"	Velcro connection	€ 15,00
	CONDOR CONCRETE 3	GRIT 60	Ø 100mm – 4"	Velcro connection	€ 22,00
	CONDOR CONCRETE 4	GRIT 120	Ø 100mm – 4"	Velcro connection	€ 22,00
	CONDOR CONCRETE 5	GRIT 220	Ø 100mm – 4"	Velcro connection	€ 22,00
	CONDOR CONCRETE 6	GRIT 400	Ø 100mm – 4"	Velcro connection	€ 22,00
	CONDOR CONCRETE 7	GRIT 800	Ø 100mm – 4"	Velcro connection	€ 22,00
	CONDOR CONCRETE 8	GRIT 1800	Ø 100mm – 4"	Velcro connection	€ 22,00
	C-KS 3	GRIT 60	Ø 100mm – 4"	Plastic support connection	€ 45,00
	C-KS 4	GRIT 120	Ø 100mm – 4"	Plastic support connection	€ 45,00
	C-KS 5	GRIT 220	Ø 100mm – 4"	Plastic support connection	€ 45,00
	C-KS 6	GRIT 400	Ø 100mm – 4"	Plastic support connection	€ 45,00
	C-KS 7	GRIT 800	Ø 100mm – 4"	Plastic support connection	€ 45,00
	C-KS 8	GRIT 1800	Ø 100mm – 4"	Plastic support connection	€ 45,00
	C-KS 3 140mm	GRIT 60	Ø 140mm – 5,5"	Velcro connection	€ 55,00
	C-KS 4 140mm	GRIT 120	Ø 140mm – 5,5"	Velcro connection	€ 55,00
	C-KS 5 140mm	GRIT 220	Ø 140mm – 5,5"	Velcro connection	€ 55,00
	C-KS 6 140mm	GRIT 400	Ø 140mm – 5,5"	Velcro connection	€ 55,00
	C-KS 7 140mm	GRIT 800	Ø 140mm – 5,5"	Velcro connection	€ 55,00
	C-KS 8 140mm	GRIT 1800	Ø 140mm – 5,5"	Velcro connection	€ 55,00
	COUGARFLEX CONCRETE 3	GRIT 60	Ø 125mm – 5"	Velcro connection	€ 48,00
	COUGARFLEX CONCRETE 4	GRIT 120	Ø 125mm – 5"	Velcro connection	€ 48,00
	COUGARFLEX CONCRETE 5	GRIT 220	Ø 125mm – 5"	Velcro connection	€ 48,00
	COUGARFLEX CONCRETE 6	GRIT 400	Ø 125mm – 5"	Velcro connection	€ 48,00
	COUGARFLEX CONCRETE 7	GRIT 800	Ø 125mm – 5"	Velcro connection	€ 48,00
	COUGARFLEX CONCRETE 8	GRIT 1800	Ø 125mm – 5"	Velcro connection	€ 48,00
	COUGARFLEX CONCRETE 3	GRIT 60	Ø 150mm – 6"	Velcro connection	€ 39,00
	COUGARFLEX CONCRETE 4	GRIT 120	Ø 150mm – 6"	Velcro connection	€ 39,00
	COUGARFLEX CONCRETE 5	GRIT 220	Ø 150mm – 6"	Velcro connection	€ 39,00
	COUGARFLEX CONCRETE 6	GRIT 400	Ø 150mm – 6"	Velcro connection	€ 39,00
	COUGARFLEX CONCRETE 7	GRIT 800	Ø 150mm – 6"	Velcro connection	€ 39,00
	COUGARFLEX CONCRETE 8	GRIT 1800	Ø 150mm – 6"	Velcro connection	€ 39,00

COUGARFLEX CONCRETE: Available also 100mm - 4" / 140mm - 5,5"

Products FOR CONCRETE SYSTEM

	DESCRIPTION	PRICE								
	<p>CONCRETE HARDNER (Sodium / Potassium densifier) Concrete Hardner KS10 improves the hardness and quality of new and existing concrete floors. Easy-to-use water-based solution. When sprayed on new or existing concrete, it penetrates up to 4mm where it reacts with free calcium to form insoluble calcium silica hydrate, which makes concrete water, stain and abrasion resistant for easier maintenance and longer life. It is also suitable for concrete polishing procedures and helps prolong the life of polished finishes.</p> <p>Concrete Hardner KS 10 Lt 5 (mixing ratio 1:3)</p> <p>Concrete Hardner KS 10 Lt 25 (mixing ratio 1:3)</p> <p>Concrete Hardner KS 35 Lt 25 (mixing ratio 1:2)</p>	<p>€ 49,50</p> <p>€ 215,00</p> <p>€ 159,00</p>								
	<p>CONCRETE HARDNER LITHIUM (Lithium densifier) Concrete Hardner Lithium improves the hardness and quality of new and existing concrete floors. Easy-to-use water-based solution. When sprayed on new or existing concrete, it penetrates up to 7mm where it reacts with free calcium to form insoluble calcium silica hydrate, which makes concrete water, stain and abrasion resistant for easier maintenance and longer life. It is also suitable for concrete polishing procedures and helps prolong the life of polished finishes.</p> <p>Concrete Hardner Lithium Lt 5 (Ready to use)</p> <p>Concrete Hardner Lithium Lt 25 (Ready to use)</p> <p>Concrete Hardner Lithium HQ Lt 25 (High concentration to be diluted 1:3)</p>	<p>€ 90,00</p> <p>€ 375,00</p> <p>€ 790,00</p>								
	<p>CONCRETE KS SHIELD Penetrating stain and water repellent for polished concrete. Special formulation which makes the surface water repellent while leaving its aesthetic characteristics and substrate transpirability unchanged. Invisible protection and adds in durability and resistance against wear due to weather and many other agents. It prevents fluorescence and mold build-ups. It does not create a film, but penetrates into the concrete covering the inner surface of each pore.</p> <p>Concrete KS Shield Lt 5</p> <p>Concrete KS Shield BOX 4x5 Lt</p>	<p>€ 85,50</p> <p>€ 326,00</p>								
	<p>CONCRETE GUARD LITHIUM High gloss, oil-repellent treatment, stain and wear resistant concrete sealer. Once applied and burnished it makes a very hard film for maximum protection. It can be applied directly on the floor by using microfiber cloth. After application we suggest to polishing the surface with high speed machine. Suitable for industrial areas with heavy traffic.</p> <p>Concrete Guard Lithium Plus Lt 5</p> <p>Concrete Guard Lithium Plus Lt 25</p> <p>Concrete Guard Lithium HQ (High concentration) Lt 5</p> <p>Concrete Guard Lithium HQ (High concentration) Lt 25</p>	<p>€ 159,00</p> <p>€ 735,00</p> <p>€ 238,00</p> <p>€ 1090,00</p>								
	<p>CONCRETE GLOSS PRIMER (Lithium Based) Concrete Gloss Primer is the perfect bonding base before the application of Concrete Gloss Finish. The combination of the 2 products protects the surface against wear due to heavy equipment and traffic, stain and UV degradation. Recommended level of grinding/polishing before application is 200-400 grit or higher. The floor must be cleaned and dry.</p> <p>CONCRETE GLOSS FINISH (Lithium Based) Concrete sealer, oil repellent treatment, once applied and burnished it makes a very hard film for maximum protection against wear due to heavy equipment and traffic. Extremely durable, perfect protection against stain formation and suitable for extreme requirements in food service and retail stores.</p> <table border="1" data-bbox="488 1738 740 1839"> <thead> <tr> <th>*Mixing</th> <th>Ratio</th> </tr> </thead> <tbody> <tr> <td>Soft Concrete</td> <td>1:16</td> </tr> <tr> <td>Medium Concrete</td> <td>1:18</td> </tr> <tr> <td>Hard Concrete</td> <td>1:24</td> </tr> </tbody> </table> <p>Concrete Gloss Primer Lt 1 Concentrated Product (to be diluted*)</p> <p>Concrete Gloss Finish Lt 1 Concentrated Product (to be diluted*)</p>	*Mixing	Ratio	Soft Concrete	1:16	Medium Concrete	1:18	Hard Concrete	1:24	<p>€ 155,00</p> <p>€ 139,00</p>
*Mixing	Ratio									
Soft Concrete	1:16									
Medium Concrete	1:18									
Hard Concrete	1:24									
	<p>CONCRETE OWR STRONG H2O Water-based impregnating agent, ideal to protect all concrete surfaces. Excellent repellency to oily substances and water. Anti stain product, non-flammable, easy to use, doesn't make films and lets the surfaces breathe. Increase the life of the floor and keep the aesthetic of the surface. Reduces the damage caused by freezing / thawing and salt efflorescence. Can be applied on the floor after last grinding step. Apply on a dry and clean surface. Spray the product on the floor and spread with a micro fiber cloth. Wait 24 hours before applying the final sealer (Concrete Guard Lithium).</p> <p>Concrete OWR Strong H2O Lt 5</p> <p>Concrete OWR Strong H2O Lt 20</p>	<p>€ 195,00</p> <p>€ 925,00</p>								

Products FOR CONCRETE

	DESCRIPTION	PRICE								
	<p>CONCRETE OIL CLEANER Biphasic alkaline detergent. Industrial detergent specifically designed for rapid and deep cleaning of industrial surfaces in sludge concrete and heavy dirt. Super-concentrated detergent suitable to solubilize and to eliminate quickly various types of dirt. High penetrating, emollient and emulsifying power. Concrete Oil Cleaner also removes the most tenacious dirt, guaranteeing deeper cleaning. Concrete Oil Cleaner can be used for extraordinary cleaning on various industrial surfaces such as cement and synthetic coatings. MIXING RATIO from 1:5 to 1:8</p>									
	Concrete Oil Cleaner Lt 12	€ 260,00								
	<p>CONCRETE FILLER For grouting and filling up small holes and micro cracks of the concrete floor. Can be applied directly on the floor during the grinding operation step grit 120. Concrete Filler fills the surface with the same color. Compatible with densifiers, sealers and Color Dye.</p>									
	Concrete Filler (Sodium / Potassium Based) Lt 25 - Concentrated Product (to be diluted 1:9 with water)	€ 480,00								
	<p>CONCRETE FILLER PLUS (Lithium Based) Concrete Filler Plus Lt 1 - Concentrated Product (to be diluted*)</p> <table border="1"> <thead> <tr> <th>*Mixing</th> <th>Ratio</th> </tr> </thead> <tbody> <tr> <td>Soft Concrete</td> <td>1:16</td> </tr> <tr> <td>Medium Concrete</td> <td>1:18</td> </tr> <tr> <td>Hard Concrete</td> <td>1:24</td> </tr> </tbody> </table>	*Mixing	Ratio	Soft Concrete	1:16	Medium Concrete	1:18	Hard Concrete	1:24	€ 110,00
*Mixing	Ratio									
Soft Concrete	1:16									
Medium Concrete	1:18									
Hard Concrete	1:24									
	<p>CONCRETE GROUT Specific product cement based born to fill and repairing micro cracks and micro holes on concrete floors. Dry in 24 hours.</p>									
	CRACKS From 0 to 5 mm (Kg 5)	€ 109,00								
	CRACKS From 5 to 25 mm (Kg 25)	€ 149,00								
	<p>CONCRETE GROUT A+B Bicomponent resin ideal to seal and grouting large and micro holes and cracks on concrete floors. It can be mixed with grinding dust up to 50% in order to obtain the desired color and consistency. Dry in 20/25 minutes.</p>									
	Concrete Grout A+B Kg 5 (Hardner agent included)	€ 165,00								
	<p>KS SLURRY DRYER <i>Solidifier for concrete and natural stones sludges</i> Super absorbent polymer designed by Klinsystem to absorb and retain fluids in order to reduce the volume and simplify transport. It is a soluble polymer with a white granular consistency in its dry form. When it comes in contact with the sludge, it forms a gel with excellent mechanical stability that holds these liquids, even under stress, since absorption is based on a physical-chemical process. The performance of superabsorbent polymers is related to the amount of sediment present in the liquids to be absorbed. Use: Spread on slurry and sludges and wait for reaction. Application: Concrete grinding, Concrete and stones saw cutting and drilling, Concrete areas to rinse Natural stone grinding and restoration.</p>									
	KS Slurry Dryer Kg 20	€ 285,00								

CONCRETE COLOR DYE

Solvent based dyes are the most commonly used products for coloring concrete floors. **Micronized dye particles are catalyzed in acetone, which in turn penetrate into the concrete surface.** Thanks to the very fine pigments, the color penetrates deep into the concrete surface. The more porous the concrete, the deeper the dye color will saturate.

The use of dyes opens a wide spectrum of vivid colors not available with iron oxide or acid stains. It is important to note that these dyes are **not UV stable and should only be used indoors.** The dyes are non-reactive and moisture can affect the longevity of the color, therefore it is highly recommended that moisture tests should be carried out and a topical sealer like Concrete Guard Lithium or Concrete Gloss Finish should be used for additional protection.



CONCRETE COLOR PLUS (LIQUID)

Concentrated liquid color solution to be dilute in 4 liters of Acetone.

Application: all concrete floors. **Colors:** BLACK (5395C), RED (032C), GREEN (369C), BLUE (2925C). The color gradation may vary according to the composition of the concrete, so we recommend to do a preliminary color test.

Concrete Color Plus 250 ml (quantity for 4 Lt of Acetone) € 56,50







Marble POLISHING SYSTEM

STANDARD PROCESS:

- 1) Start grinding with Metal bond diamond tools **KSM1 Grit 60** and continue until the floor is perfectly levelled. If the floor is very unlevelled or has big lippages, we suggest to start grinding with **KSMO Grit 36**.
- 2) Proceed with Metal tool **KSM2 Grit 120** to eliminate the scratch created with the KSM1.
- 3) Continue with Resin bond diamond tool **Jumpflex Marble 3** or **M-KS3 Grit 6** (for abrasive marble we suggest to use **Pavelux Marble 3 and 4** pag. 60).
- 4) Proceed with Resin tool **Jumpflex Marble 4** or **M-KS4 Grit 120**.
- 5) Continue with Resin tool **Jumpflex Marble 5** or **M-KS5 Grit 220**, **Jumpflex Marble 6** or **M-KS6 Grit 400** and **Jumpflex Marble 7** or **M-KS7 Grit 800**. Usually after step with Resin tool Grit 800, you can polishing the floor using the **POLISHING POWDER** in according to the kind of marble (pag. 60). For hard stones and colored marbles, continue the process with **Jumpflex Marble 8** or **M-KS8 Grit 1800** and **Jumpflex Marble 9** or **M-KS9 Grit 3500**.
- 6) Polishing the floor with the most specific **POLISHING POWDER** in according to the kind of marble (pag. 60).
- 7) Final step, wash the floor with water and **KLINSOAP** to protect the surface and to improve the gloss.

WAX AND MASTIC FOR MARBLE

Best quality mastic for repairing marble and natural stone floors





	DESCRIPTION	PRICE
	<p>WAXDUR CREAM Specific water-based WAX for polishing marble, granite and natural stone. It polishes and water-proofing the floors. Gives an excellent polish effect with a good water and oil repellency.</p> <p>Waxdur cream Kg 1</p>	€ 36,00
	<p>MASTIC SOLID Solid polyester mastic for marble and granite for general repairing, grouting and for vertical application. Available in colours: Straw, white, black, green, red.</p> <p>Mastic solid BOX 12x1 Kg</p>	€ 118,00
	<p>MASTIC LIQUID Liquid polyester mastic for marble and granite for general repairing, grouting and for vertical application. Available in colours: Straw, white, black, green, red.</p> <p>Mastic liquid BOX 12x1 Kg</p>	€ 118,00
	<p>MASTIC TRANSPARENT Solid / Liquid Transparent high quality polyester mastic. Perfect for travertine. Ideal for consolidating stone or repairing fine cracks or fractures. Faster curing time suitable for wide cracks.</p> <p>Mastic transparent Solid BOX 12x1 Kg</p> <p>Mastic transparent Liquid BOX 12x1 Kg</p>	€ 215,00 € 205,00
	<p>EPOXY RESIN COMPONENT A + B Epoxy resin 2 components (Resin and Hardener 50/50), ideal for consolidating stone or REPAIRING fine cracks or fractures. Faster curing time and more suitable for wide cracks. It can be coloured to match any stone.</p> <p>Epoxy resin Component A Kg 1</p> <p>Epoxy resin Component B Kg 1</p>	€ 27,50 € 23,50

Marble POLISHING SYSTEM

KS M





METAL BOND DIAMOND TOOLS

Suitable for marble and natural stone

DESCRIPTION		PRICE
	KS M0 GRIT 36 Ø 240mm - 9,5" 12 segments Quick Change	€ 235,00
	KS M1 GRIT 60 Ø 240mm - 9,5" 12 segments Quick Change	€ 235,00
	KS M2 GRIT 120 Ø 240mm - 9,5" 12 segments Quick Change	€ 235,00
<small>* KSM Ø 240mm available also 16 segments</small>		
	KS M0 GRIT 36 Ø 200mm - 8" 7 segments Quick Change	€ 139,00
	KS M1 GRIT 60 Ø 200mm - 8" 7 segments Quick Change	€ 139,00
	KS M2 GRIT 120 Ø 200mm - 8" 7 segments Quick Change	€ 139,00
	KS M0 GRIT 36 Ø 140mm - 5,5" 6 segments Plastic Support	€ 130,50
	KS M1 GRIT 60 Ø 140mm - 5,5" 6 segments Plastic Support	€ 130,50
	KS M2 GRIT 120 Ø 140mm - 5,5" 6 segments Plastic Support	€ 130,50
	KS M0 GRIT 36 Ø 100mm - 4" 6 segments Plastic Support	€ 130,50
	KS M1 GRIT 60 Ø 100mm - 4" 6 segments Plastic Support	€ 127,00
	KS M2 GRIT 120 Ø 100mm - 4" 6 segments Plastic Support	€ 127,00



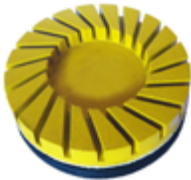

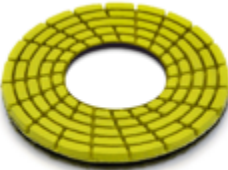

RESIN BOND DIAMOND TOOLS

Suitable for marble and natural stone

DESCRIPTION		PRICE
	JUMPFLEX MARBLE 3 GRIT 60 Ø 75mm - 3" Velcro connection	€ 24,00
	JUMPFLEX MARBLE 4 GRIT 120 Ø 75mm - 3" Velcro connection	€ 24,00
	JUMPFLEX MARBLE 5 GRIT 220 Ø 75mm - 3" Velcro connection	€ 24,00
	JUMPFLEX MARBLE 6 GRIT 400 Ø 75mm - 3" Velcro connection	€ 24,00
	JUMPFLEX MARBLE 7 GRIT 800 Ø 75mm - 3" Velcro connection	€ 24,00
	JUMPFLEX MARBLE 8 GRIT 1800 Ø 75mm - 3" Velcro connection	€ 24,00
	JUMPFLEX MARBLE 3 GRIT 60 Ø 100mm - 4" Velcro connection	€ 31,00
	JUMPFLEX MARBLE 4 GRIT 120 Ø 100mm - 4" Velcro connection	€ 31,00
	JUMPFLEX MARBLE 5 GRIT 220 Ø 100mm - 4" Velcro connection	€ 31,00
	JUMPFLEX MARBLE 6 GRIT 400 Ø 100mm - 4" Velcro connection	€ 31,00
	JUMPFLEX MARBLE 7 GRIT 800 Ø 100mm - 4" Velcro connection	€ 31,00
	JUMPFLEX MARBLE 8 GRIT 1800 Ø 100mm - 4" Velcro connection	€ 31,00
	M-KS 3 GRIT 60 Ø 100mm - 4" Plastic support connection	€ 45,00
	M-KS 4 GRIT 120 Ø 100mm - 4" Plastic support connection	€ 45,00
	M-KS 5 GRIT 220 Ø 100mm - 4" Plastic support connection	€ 45,00
	M-KS 6 GRIT 400 Ø 100mm - 4" Plastic support connection	€ 45,00
	M-KS 7 GRIT 800 Ø 100mm - 4" Plastic support connection	€ 45,00
	M-KS 8 GRIT 1800 Ø 100mm - 4" Plastic support connection	€ 45,00
	M-KS 3 GRIT 60 Ø 140mm - 5,5" Velcro connection	€ 47,00
	M-KS 4 GRIT 120 Ø 140mm - 5,5" Velcro connection	€ 47,00
	M-KS 5 GRIT 220 Ø 140mm - 5,5" Velcro connection	€ 47,00
	M-KS 6 GRIT 400 Ø 140mm - 5,5" Velcro connection	€ 47,00
	M-KS 7 GRIT 800 Ø 140mm - 5,5" Velcro connection	€ 47,00
	M-KS 8 GRIT 1800 Ø 140mm - 5,5" Velcro connection	€ 47,00
	COUGARFLEX MARBLE 3 GRIT 60 Ø 150mm - 6" Velcro connection	€ 56,00
	COUGARFLEX MARBLE 4 GRIT 120 Ø 150mm - 6" Velcro connection	€ 56,00
	COUGARFLEX MARBLE 5 GRIT 220 Ø 150mm - 6" Velcro connection	€ 56,00
	COUGARFLEX MARBLE 6 GRIT 400 Ø 150mm - 6" Velcro connection	€ 56,00
	COUGARFLEX MARBLE 7 GRIT 800 Ø 150mm - 6" Velcro connection	€ 56,00
	COUGARFLEX MARBLE 8 GRIT 1800 Ø 150mm - 6" Velcro connection	€ 56,00

COUGARFLEX MARBLE: Available also 100mm - 4" / 125mm - 5" / 140mm - 5,5"

Products and chemicals for marble and natural stone



	DESCRIPTION	PRICE
	<p>SHINE GREEN Polishing cream for marbles, artificial marbles and agglomerates. SHINE GREEN increases wear resistance, powerful protection against dust, acid/alkalin, washing, scratches and stain, and excellent self-cleaning properties. Thanks to the thermal force of the crystallization, SHINE GREEN penetrate into the molecular gaps of the floor and then solidify into high-strength, rigid transparent protective layer and form a crystal shield on the surface of the stone.</p>	
	Shine Green Kg 1	€ 36,00
	<p>KLINSOAP Shining soap for marble and natural stone. Improves and protects the surface, high quality combination cleaner that simultaneously forms a water insoluble and dirt repellent barrier. Dilute by 0.5 liters every 10 liters of water for daily cleaning, and increase to 1-2 liters per 10 liters for added sealing impregnation effect. Good as final cleaning after polishing procedure of stone, concrete, terrazzo, timber and even vinyl flooring.</p>	
	Klinsoap Box 4x5 Lt	€ 356,00
	<p>KRISTAL & LUX Crystallizing liquid specially formulated for vitrifying surfaces of marble and terrazzo. It provides waterproofing and hardness for high traffic resistance. No-slippery, high and long lasting protection and not marks footprints. Mirror Shine effect. Can be used for periodical maintenance of floors already crystallized. Instructions: spray a little quantity of product, spread the product uniformly with a single disc machine fitted with a steel wool pad and work until the product gets completely dry.</p>	
	Kristal & Lux BOX 3x5 Lt	€ 115,00
	<p>KS IDROPROOF Water repellent, waterproofing agent/sealer for both indoor and outdoor applications. It's ideal for marble, granite and any other natural stone.</p>	
	KS Idroproof Lt 1	€ 25,50
	<p>STONE VARNISH Self-polishing varnish suitable to reach the shine where it is not easy to polish by machine. Gives an excellent polish effect with a good water and oil repellency. It can be used on any natural stones and all marbles.</p>	
	Stone varnish Lt 1	€ 18,15
	<p>ANTIQUE EFFECT Waterproofing, wet satin effect for marble and granite floors.</p>	
	Antique effect Lt 1	€ 18,70
	<p>BRILL & LUX Solvent based / Water based Crystallizing liquid product for the polishing of marble, terrazzo, limestone, travertine and other types of natural stone surfaces. Self-polishing varnish with a "wet look effect" for marble, granite and natural stones.</p>	
	Brill & Lux Lt 1 (solvent based)	€ 22,95
	Brill & Lux Lt 1 (water based)	€ 16,20

Products FOR MARBLE





POLISH POWDER FOR MARBLE Best quality polishing powders made in Italy

DESCRIPTION		PRICE
	POLISH POWDER KSMT High quality polish powder for soft and abrasive marbles like Carrara, limestone etc. KSMT very good quality Polish Powder, excellent solution for daily cleaning of hard surfaces. Fine abrasive, can be use to remove fungus, soap scum build-up and embedded stains in grouting immediately. Suitable for use in big areas, hotels, shopping mall, on all type of natural stone surfaces.	
	Polish powder KSMT 5 Kg	€ 86,00
	Polish powder KSMT 20 Kg	€ 340,00
	POLISH POWDER KS92 High quality polish powder for standard marbles and limestone. Excellent solution for daily cleaning of natural surfaces. It is fine abrasive adapt to remove fungus, soap scum buildup and embedded stains in grouting immediately. Suitable for use in big areas, hotels, shopping mall, on all type of natural stone surfaces.	
	Polish powder KS92 5 Kg	€ 82,00
	Polish powder KS92 20 Kg	€ 325,00
	POLISH POWDER KS85 High quality yellow polish powder for marble and terrazzo polishing after grinding steps. Can be used for daily maintenance of polishing marble, terrazzo, porcelain and glass surfaces. It is fine abrasive adapt to remove fungus, soap scum build-up and embedded stains in grouting immediately. Suitable for use in big areas, hotels, shopping mall, on all type of natural stone surfaces.	
	Polish powder KS85 5 Kg	€ 75,00
	Polish powder KS85 20 Kg	€ 305,00
	POLISH POWDER KS80 High quality yellow polish powder for marble and terrazzo polishing after grinding steps. Can be used for daily maintenance of polishing marble, terrazzo, porcelain and glass surfaces. It is fine abrasive adapt to remove fungus, soap scum build-up and embedded stains in grouting immediately. Suitable for use in big areas, hotels, shopping mall, on all type of natural stone surfaces.	
	Polish powder KS80 5 Kg	€ 75,00
	Polish powder KS80 20 Kg	€ 305,00



PAVELUX Synthetic tools for removing mastic and grinding abrasive floors where resin tools have not long life

Pavelux for Marble <small>We suggest to use PAVELUX MARBLE 3 and 4 in place of resin tool Grit 60 and 120 (see procedure pag. 57).</small>	
	PAVELUX MARBLE 3 GRIT 60 Ø 100mm – 4" Velcro connection € 15,50
	PAVELUX MARBLE 4 GRIT 120 Ø 100mm – 4" Velcro connection € 15,50
	PAVELUX MARBLE 5 GRIT 220 Ø 100mm – 4" Velcro connection € 15,50
	PAVELUX MARBLE 6 GRIT 400 Ø 100mm – 4" Velcro connection € 15,50
	PAVELUX MARBLE 7 GRIT 800 Ø 100mm – 4" Velcro connection € 15,50
	PAVELUX MARBLE 8 GRIT 1800 Ø 100mm – 4" Velcro connection € 15,50
	PAVELUX MARBLE 9 GRIT 3500 Ø 100mm – 4" Velcro connection € 15,50
Pavelux for Granite and Gres <small>We suggest to use PAVELUX GRANITE 4 and 5 to close all the micro-porosity of the granite. Continue with resin tools Grit 400 (procedure pag. 62).</small>	
	PAVELUX GRANITE 3 GRIT 60 Ø 100mm – 4" Velcro connection € 15,50
	PAVELUX GRANITE 4 GRIT 120 Ø 100mm – 4" Velcro connection € 15,50
	PAVELUX GRANITE 5 GRIT 220 Ø 100mm – 4" Velcro connection € 15,50
	PAVELUX GRANITE 6 GRIT 400 Ø 100mm – 4" Velcro connection € 15,50
	PAVELUX GRANITE 7 GRIT 800 Ø 100mm – 4" Velcro connection € 15,50
	PAVELUX GRANITE 8 GRIT 1800 Ø 100mm – 4" Velcro connection € 15,50
	PAVELUX GRANITE 9 GRIT 3500 Ø 100mm – 4" Velcro connection € 15,50

*Available PAVELUX Ø 100mm – 4" with Plastic Support.

DESCRIPTION		PRICE																									
	<p>BUSH HAMMER PLATE 3 ROLLERS Ø 240mm - 9,5" - Quick Attack (with greaser) Special tool suitable for many applications: safety anti-slip surfaces on concrete, marble, granite and natural stones</p> <ul style="list-style-type: none"> • Floor preparation, glue, varnish and resin coating removal • To break-down thick coating difficult to remove with normal diamond tools • Bush Hammer allow to get "face-see effect" "on precast panels" • Scarification of any kind of surface • Orange-peel skin effect on concrete and any surface 	€ 1095,00																									
	<p>DOUBLE RING GRINDING CUP Metal bond diamond tools grinding cup suitable for hand machines</p> <table border="1"> <tr> <td>GC125#36</td> <td>Ø 125mm - 5"</td> <td>GRIT 36</td> <td>COARSE</td> <td>€ 105,00</td> </tr> <tr> <td>GC125#60</td> <td>Ø 125mm - 5"</td> <td>GRIT 60</td> <td>MEDIUM</td> <td>€ 105,00</td> </tr> <tr> <td>GC125#120</td> <td>Ø 125mm - 5"</td> <td>GRIT 120</td> <td>FINE</td> <td>€ 105,00</td> </tr> </table>	GC125#36	Ø 125mm - 5"	GRIT 36	COARSE	€ 105,00	GC125#60	Ø 125mm - 5"	GRIT 60	MEDIUM	€ 105,00	GC125#120	Ø 125mm - 5"	GRIT 120	FINE	€ 105,00											
GC125#36	Ø 125mm - 5"	GRIT 36	COARSE	€ 105,00																							
GC125#60	Ø 125mm - 5"	GRIT 60	MEDIUM	€ 105,00																							
GC125#120	Ø 125mm - 5"	GRIT 120	FINE	€ 105,00																							
	<p>METAL BOND TURBO CUP Designed for grinding and shaping stone and concrete surfaces. Offered in Coarse, Medium, and Fine grit.</p> <table border="1"> <tr> <td>TC5-M14-C Turbo Cup, M14</td> <td>Ø 125mm - 5"</td> <td>GRIT Coarse</td> <td>€ 134,00</td> </tr> <tr> <td>TC5-M14-M Turbo Cup, M14</td> <td>Ø 125mm - 5"</td> <td>GRIT Medium</td> <td>€ 134,00</td> </tr> <tr> <td>TC5-M14-F Turbo Cup, M14</td> <td>Ø 125mm - 5"</td> <td>GRIT Fine</td> <td>€ 134,00</td> </tr> </table>	TC5-M14-C Turbo Cup, M14	Ø 125mm - 5"	GRIT Coarse	€ 134,00	TC5-M14-M Turbo Cup, M14	Ø 125mm - 5"	GRIT Medium	€ 134,00	TC5-M14-F Turbo Cup, M14	Ø 125mm - 5"	GRIT Fine	€ 134,00														
TC5-M14-C Turbo Cup, M14	Ø 125mm - 5"	GRIT Coarse	€ 134,00																								
TC5-M14-M Turbo Cup, M14	Ø 125mm - 5"	GRIT Medium	€ 134,00																								
TC5-M14-F Turbo Cup, M14	Ø 125mm - 5"	GRIT Fine	€ 134,00																								
	<p>EDGE MASTER 5-STEP GRINDING SYSTEM High performing ceramic bond to refine and blend your edge work faster and more efficiently for concrete floors. Step 1 Grit Extra Coarse removes deep scratches or any hard topical materials on the edges. In most cases, start with Step 2 Grit Coarse. Wet and dry use.</p> <table border="1"> <tr> <td>EM-5-XC Edge Master Ceramic Turbo Cup, M14</td> <td>Ø 125mm - 5"</td> <td>GRIT Extra Coarse</td> <td>STEP 1</td> <td>€ 122,00</td> </tr> <tr> <td>EM-5-C Edge Master Ceramic Turbo Cup, M14</td> <td>Ø 125mm - 5"</td> <td>GRIT Coarse</td> <td>STEP 2</td> <td>€ 122,00</td> </tr> <tr> <td>EM-5-M Edge Master Ceramic Turbo Cup, M14</td> <td>Ø 125mm - 5"</td> <td>GRIT Medium</td> <td>STEP 3</td> <td>€ 122,00</td> </tr> <tr> <td>EM-5-F Edge Master Ceramic Turbo Cup, M14</td> <td>Ø 125mm - 5"</td> <td>GRIT Fine</td> <td>STEP 4</td> <td>€ 122,00</td> </tr> <tr> <td>EM-5-XF Edge Master Ceramic Turbo Cup, M14</td> <td>Ø 125mm - 5"</td> <td>GRIT Extra Fine</td> <td>STEP 5</td> <td>€ 122,00</td> </tr> </table>	EM-5-XC Edge Master Ceramic Turbo Cup, M14	Ø 125mm - 5"	GRIT Extra Coarse	STEP 1	€ 122,00	EM-5-C Edge Master Ceramic Turbo Cup, M14	Ø 125mm - 5"	GRIT Coarse	STEP 2	€ 122,00	EM-5-M Edge Master Ceramic Turbo Cup, M14	Ø 125mm - 5"	GRIT Medium	STEP 3	€ 122,00	EM-5-F Edge Master Ceramic Turbo Cup, M14	Ø 125mm - 5"	GRIT Fine	STEP 4	€ 122,00	EM-5-XF Edge Master Ceramic Turbo Cup, M14	Ø 125mm - 5"	GRIT Extra Fine	STEP 5	€ 122,00	
EM-5-XC Edge Master Ceramic Turbo Cup, M14	Ø 125mm - 5"	GRIT Extra Coarse	STEP 1	€ 122,00																							
EM-5-C Edge Master Ceramic Turbo Cup, M14	Ø 125mm - 5"	GRIT Coarse	STEP 2	€ 122,00																							
EM-5-M Edge Master Ceramic Turbo Cup, M14	Ø 125mm - 5"	GRIT Medium	STEP 3	€ 122,00																							
EM-5-F Edge Master Ceramic Turbo Cup, M14	Ø 125mm - 5"	GRIT Fine	STEP 4	€ 122,00																							
EM-5-XF Edge Master Ceramic Turbo Cup, M14	Ø 125mm - 5"	GRIT Extra Fine	STEP 5	€ 122,00																							

FLOOR PADS Floor pads for polishing, buffing and daily cleaning

DESCRIPTION		PRICE
 <p>PADLUX NATURAL FLOOR PAD Formulated with natural fibers for polishing marble, granite, concrete and natural stone. Can be used specially with Polishing powder and also with High-speed machine. Minimum order is 1 BOX composed by 5 pieces.</p>  <ul style="list-style-type: none"> • WHITE FLOOR PAD For polishing floors. • RED FLOOR PAD For spray cleaning. • BLACK FLOOR PAD For wet stripping hard floor. • GREEN FLOOR PAD For wet stripping on linoleum, rubber. <p>Minimum order is 1 BOX composed by 5 pieces.</p>	<p>PADLUX NATURAL FLOOR PAD Ø 100mm - 4" € 5,00</p> <p>PADLUX NATURAL FLOOR PAD Ø 150mm - 6" € 5,85</p> <p>PADLUX NATURAL FLOOR PAD Ø 240mm - 9,5" € 7,75</p> <p>PADLUX NATURAL FLOOR PAD Ø 280mm - 11" € 8,80</p> <p>PADLUX NATURAL FLOOR PAD Ø 330mm - 13" € 11,15</p> <p>PADLUX NATURAL FLOOR PAD Ø 430mm - 17" € 12,85</p> <p>PADLUX NATURAL FLOOR PAD Ø 540mm - 21" € 18,70</p> <p>PADLUX NATURAL FLOOR PAD Ø 660mm - 26" € 31,50</p> <p>PADLUX NATURAL FLOOR PAD Ø 710mm - 28" € 35,00</p>	
	FLOOR PADS Ø 100mm - 4" € 4,60	
	FLOOR PADS Ø 150mm - 6" € 5,50	
	FLOOR PADS Ø 240mm - 9,5" € 7,30	
	FLOOR PADS Ø 280mm - 11" € 7,75	
	FLOOR PADS Ø 330mm - 13" € 8,20	
	FLOOR PADS Ø 430mm - 17" € 11,20	
	FLOOR PADS Ø 540mm - 21" € 17,30	
	FLOOR PADS Ø 660mm - 26" € 31,00	
	FLOOR PADS Ø 710mm - 28" € 33,50	

Granite POLISHING SYSTEM



STANDARD PROCESS:

- 1) Start grinding with Metal bond **KSG1 Grit 36** and continue until the floor is perfectly levelled.
- 2) Proceed with Metal tool **KSG2 Grit 60** to eliminate the scratch created from the KSG1.
- 3) Continue with Metal tools **KSG3 Grit 120** until the floor is smooth and no scratches.
- 4) Continue with Resin bond diamond tool **Jumpflex Granite 3** or **G-KS3 Grit 60**, **Jumpflex Granite 4** or **G-KS4 Grit 120**, (we suggest to use **PAVELUX GRANITE 4 and 5** to close all the micro-porosity of the granite)
- 5) Continue with **Jumpflex Granite 5** or **G-KS5 Grit 220**, **Jumpflex Granite 6** or **G-KS6 Grit 400**, **Jumpflex Granite 7** or **G-KS7 Grit 800**, **Jumpflex Granite 8** or **G-KS8 Grit 1800** and **Jumpflex Granite 9** or **G-KS9 Grit 3500**.
- 6) After step 9 you can polishing the floor using **POLISH POWDER GRANITE** for standard granite or **POLISH POWDER GRANITE CLEAR** for clear granite floor.
- 7) Use **SHINE BLU** crystallizing cream for final polishing and crystallization to protect and improve the gloss and the colour of the surfaces.





POLISH POWDERS AND CHEMICALS

Best quality polishing powders and product made in Italy suitable for granite and gres

	DESCRIPTION	PRICE
	<p>SHINE BLU Crystallizing cream for granite and gres. Increases wear resistance, powerful protection against dust, acid/alkalin, washing, scratches and stain, and excellent self-cleaning properties. Thanks to the thermal force of the crystallization, SHINE BLU penetrate into the molecular gaps of the floor and then solidify into high-strength, rigid transparent protective layer and form a crystal shield on the surface of the stone. SHINE BLU is a polishing cream specifically made for polishing granite and gres.</p> <p>Shine Blu Kg 1</p>	<p>€ 38,00</p>
	<p>POLISH POWDER GRANITE Excellent POLISH POWDER for daily cleaning and maintenance of granite surfaces. It is fine abrasive adapt to remove fungus, soap scum build-up and embedded stains in grouting immediately. Suitable for use in big areas, hotels, shopping mall, on all type of dark granite surfaces.</p> <p>Polish powder Granite Kg 5</p>	<p>€ 195,00</p>
	<p>POLISH POWDER GRANITE CLEAR Excellent POLISH POWDER for daily cleaning and maintenance of clear granite surfaces. It is fine abrasive adapt to remove fungus, soap scum build-up and embedded stains in grouting immediately. Suitable for use in big areas, hotels, shopping mall, on all type of clear granite surfaces.</p> <p>Polish powder Granite clear Kg 5</p>	<p>€ 195,00</p>



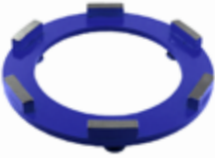

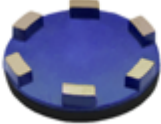
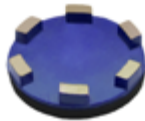
KS G METAL BOND DIAMOND TOOLS

Suitable for granite and gres

	DESCRIPTION					PRICE
	KS G1	GRIT 60	Ø 240mm - 9,5"	6 segments	Quick Change	€ 162,00
	KSG2	GRIT 120	Ø 240mm - 9,5"	6 segments	Quick Change	€ 152,50
	KS G3	GRIT 220	Ø 240mm - 9,5"	6 segments	Quick Change	€ 152,50
	<i>* KSM Ø 240mm available also 12 segments</i>					
	KS G1	GRIT 60	Ø 200mm - 8"	6 segments	Quick Change	€ 162,00
	KS G2	GRIT 120	Ø 200mm - 8"	6 segments	Quick Change	€ 152,50
	KS G3	GRIT 220	Ø 200mm - 8"	6 segments	Quick Change	€ 152,50
	KS G1	GRIT 60	Ø 140mm - 5,5"	6 segments	Plastic Support	€ 143,00
	KS G2	GRIT 120	Ø 140mm - 5,5"	6 segments	Plastic Support	€ 143,00
	KS G3	GRIT 220	Ø 140mm - 5,5"	6 segments	Plastic Support	€ 143,00
	KS G1	GRIT 60	Ø 100mm - 4"	6 segments	Plastic Support	€ 139,00
	KS G2	GRIT 120	Ø 100mm - 4"	6 segments	Plastic Support	€ 139,00
	KS G3	GRIT 220	Ø 100mm - 4"	6 segments	Plastic Support	€ 139,00

RESIN BOND DIAMOND TOOLS

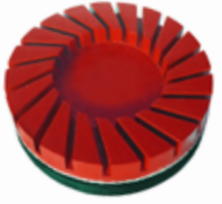
Suitable for granite and gres

	DESCRIPTION					PRICE
	JUMPFLEX GRANITE 3	GRIT 60	Ø 75mm - 3"	Velcro connection		€ 24,00
	JUMPFLEX GRANITE 4	GRIT 120	Ø 75mm - 3"	Velcro connection		€ 24,00
	JUMPFLEX GRANITE 5	GRIT 220	Ø 75mm - 3"	Velcro connection		€ 24,00
	JUMPFLEX GRANITE 6	GRIT 400	Ø 75mm - 3"	Velcro connection		€ 24,00
	JUMPFLEX GRANITE 7	GRIT 800	Ø 75mm - 3"	Velcro connection		€ 24,00
	JUMPFLEX GRANITE 8	GRIT 1800	Ø 75mm - 3"	Velcro connection		€ 24,00
	JUMPFLEX GRANITE 9	GRIT 3500	Ø 75mm - 3"	Velcro connection		€ 24,00
	JUMPFLEX GRANITE 3	GRIT 60	Ø 100mm - 4"	Velcro connection		€ 31,00
	JUMPFLEX GRANITE 4	GRIT 120	Ø 100mm - 4"	Velcro connection		€ 31,00
	JUMPFLEX GRANITE 5	GRIT 220	Ø 100mm - 4"	Velcro connection		€ 31,00
	JUMPFLEX GRANITE 6	GRIT 400	Ø 100mm - 4"	Velcro connection		€ 31,00
	JUMPFLEX GRANITE 7	GRIT 800	Ø 100mm - 4"	Velcro connection		€ 31,00
	JUMPFLEX GRANITE 8	GRIT 1800	Ø 100mm - 4"	Velcro connection		€ 31,00
	JUMPFLEX GRANITE 9	GRIT 3500	Ø 100mm - 4"	Velcro connection		€ 31,00
	G-KS 3	GRIT 60	Ø 100mm - 4"	Plastic support connection		€ 45,00
	G-KS 4	GRIT 120	Ø 100mm - 4"	Plastic support connection		€ 45,00
	G-KS 5	GRIT 220	Ø 100mm - 4"	Plastic support connection		€ 45,00
	G-KS 6	GRIT 400	Ø 100mm - 4"	Plastic support connection		€ 45,00
	G-KS 7	GRIT 800	Ø 100mm - 4"	Plastic support connection		€ 45,00
	G-KS 8	GRIT 1800	Ø 100mm - 4"	Plastic support connection		€ 45,00
	G-KS 9	GRIT 3500	Ø 100mm - 4"	Plastic support connection		€ 45,00
	G-KS 3	GRIT 60	Ø 140mm - 5,5"	Velcro connection		€ 47,00
	G-KS 4	GRIT 120	Ø 140mm - 5,5"	Velcro connection		€ 47,00
	G-KS 5	GRIT 220	Ø 140mm - 5,5"	Velcro connection		€ 47,00
	G-KS 6	GRIT 400	Ø 140mm - 5,5"	Velcro connection		€ 47,00
	G-KS 7	GRIT 800	Ø 140mm - 5,5"	Velcro connection		€ 47,00
	G-KS 8	GRIT 1800	Ø 140mm - 5,5"	Velcro connection		€ 47,00
	G-KS 9	GRIT 3500	Ø 140mm - 5,5"	Velcro connection		€ 47,00
	COUGARFLEX GRANITE 3	GRIT 60	Ø 150mm - 6"	Velcro connection		€ 56,00
	COUGARFLEX GRANITE 4	GRIT 120	Ø 150mm - 6"	Velcro connection		€ 56,00
	COUGARFLEX GRANITE 5	GRIT 220	Ø 150mm - 6"	Velcro connection		€ 56,00
	COUGARFLEX GRANITE 6	GRIT 400	Ø 150mm - 6"	Velcro connection		€ 56,00
	COUGARFLEX GRANITE 7	GRIT 800	Ø 150mm - 6"	Velcro connection		€ 56,00
	COUGARFLEX GRANITE 8	GRIT 1800	Ø 150mm - 6"	Velcro connection		€ 56,00
	COUGARFLEX GRANITE 9	GRIT 3500	Ø 150mm - 6"	Velcro connection		€ 56,00

COUGARFLEX GRANITE: Available also 100mm - 4" / 125mm - 5" / 140mm - 5,5"

Terrazzo POLISHING SYSTEM

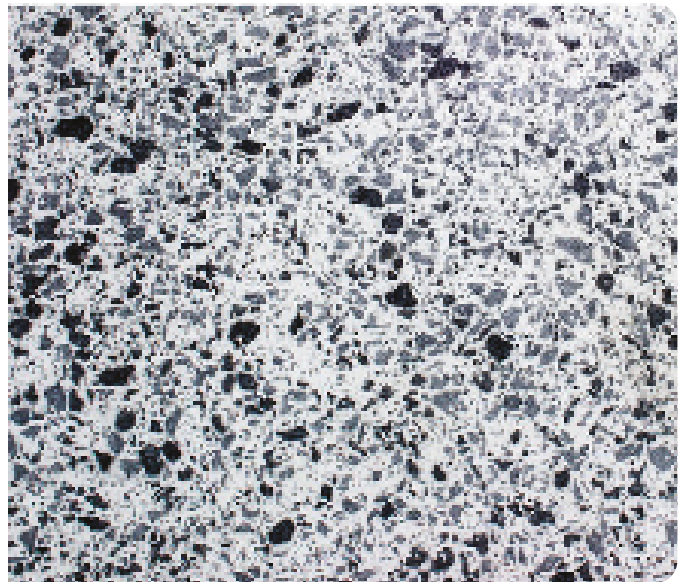
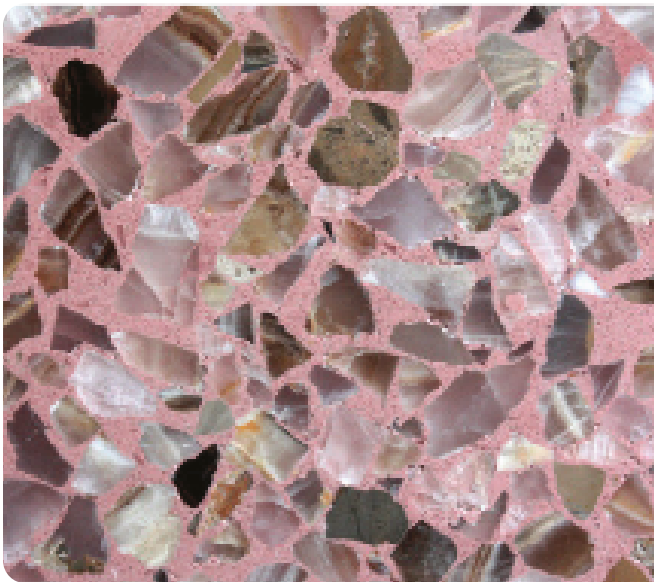

STANDARD PROCESS:

- 1) Start grinding with Metal bond diamond tools **KST1 Grit 60** and continue until the floor is perfectly levelled. If the floor is very unlevelled or has big lippages, we suggest to start grinding with **KSTO Grit 36**.
- 2) Proceed with Metal tool **KST2 Grit 120** to eliminate the scratch created with the KST1.
- 3) Continue with Resin bond diamond tool **Jumpflex Terrazzo 3** or **T-KS3 Grit 60**.
- 4) Proceed with Resin tool **Jumpflex Terrazzo 4** or **T-KS4 Grit 120** (we suggest to use Concrete Hardner to increase the hardness of the floor).
- 5) Continue with Resin tool **Jumpflex Terrazzo 5** or **T-KS5 Grit 220**, **Jumpflex Terrazzo 6** or **T-KS6 Grit 400**, **Jumpflex Terrazzo 7** or **T-KS7 Grit 800** and **Jumpflex Terrazzo 8** or **T-KS8 Grit 1800**.
- 6) Polish the floor with **POLISH POWDER MOSAIC**. Using **PADLUX Natural Floor Pad**.
- 7) Final step, wash the floor with water and **KLINSOAP** to protect the surface and to improve the gloss.



POLISH POWDERS AND CHEMICALS





Best quality polishing powders and product made in Italy suitable for terrazzo and mosaic

	DESCRIPTION	PRICE
	<p>POLISH POWDER MOSAIC Excellent POLISH POWDER for daily cleaning and maintenance of mosaic, terrazzo and palladiana floors. It is fine abrasive adapt to remove fungus, soap scum build-up and embedded stains in grouting immediately. Suitable for use in big areas, hotels, shopping mall, on all type of natural stone surfaces.</p>	€ 155,00
<p>Polish powder Mosaic Kg 5</p>		
	<p>KLINSOAP Improves and protects the surface, high quality combination cleaner that simultaneously forms a water insoluble and dirt repellent barrier. Dilute by 0.5 liters every 10 liters of water for daily cleaning, and increase to 1-2 liters per 10 liters for added sealing impregnation effect. Good as final cleaning after polishing procedure of stone, concrete, terrazzo, timber and even vinyl flooring.</p>	€ 356,00
<p>Klinsoap Box 4x5 Lt</p>		





Terrazzo POLISHING SYSTEM

KS T METAL BOND DIAMOND TOOLS

Suitable for Terrazzo and Mosaic

	DESCRIPTION					PRICE
	KS T0	GRIT 36	Ø 240mm - 9,5"	6 segments	Quick Change	€ 192,00
	KS T1	GRIT 60	Ø 240mm - 9,5"	6 segments	Quick Change	€ 180,00
	KS T2	GRIT 120	Ø 240mm - 9,5"	6 segments	Quick Change	€ 165,00
	* KS T Ø 240mm available also 12 segments					
	KS T0	GRIT 36	Ø 200mm - 8"	6 segments	Quick Change	€ 185,00
	KS T1	GRIT 60	Ø 200mm - 8"	6 segments	Quick Change	€ 175,00
	KS T2	GRIT 120	Ø 200mm - 8"	6 segments	Quick Change	€ 165,00
	KS T0	GRIT 36	Ø 140mm - 5,5"	5 segments	Plastic Support	€ 145,00
	KS T1	GRIT 60	Ø 140mm - 5,5"	5 segments	Plastic Support	€ 135,00
	KS T2	GRIT 120	Ø 140mm - 5,5"	5 segments	Plastic Support	€ 125,00
	KS T0	GRIT 36	Ø 100mm - 4"	5 segments	Plastic Support	€ 139,00
	KS T1	GRIT 60	Ø 100mm - 4"	5 segments	Plastic Support	€ 115,00
	KS T2	GRIT 120	Ø 100mm - 4"	5 segments	Plastic Support	€ 115,00

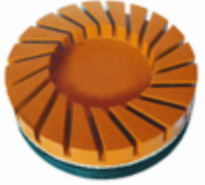
RESIN BOND DIAMOND TOOLS Suitable for terrazzo and mosaic

	DESCRIPTION					PRICE
	JUMPFLEX TERRAZZO 3	GRIT 60	Ø 75mm - 3"	Velcro connection		€ 19,50
	JUMPFLEX TERRAZZO 4	GRIT 120	Ø 75mm - 3"	Velcro connection		€ 19,50
	JUMPFLEX TERRAZZO 5	GRIT 220	Ø 75mm - 3"	Velcro connection		€ 19,50
	JUMPFLEX TERRAZZO 6	GRIT 400	Ø 75mm - 3"	Velcro connection		€ 19,50
	JUMPFLEX TERRAZZO 7	GRIT 800	Ø 75mm - 3"	Velcro connection		€ 19,50
	JUMPFLEX TERRAZZO 8	GRIT 1800	Ø 75mm - 3"	Velcro connection		€ 19,50
	JUMPFLEX TERRAZZO 3	GRIT 60	Ø 100mm - 4"	Velcro connection		€ 29,50
	JUMPFLEX TERRAZZO 4	GRIT 120	Ø 100mm - 4"	Velcro connection		€ 29,50
	JUMPFLEX TERRAZZO 5	GRIT 220	Ø 100mm - 4"	Velcro connection		€ 29,50
	JUMPFLEX TERRAZZO 6	GRIT 400	Ø 100mm - 4"	Velcro connection		€ 29,50
	JUMPFLEX TERRAZZO 7	GRIT 800	Ø 100mm - 4"	Velcro connection		€ 29,50
	JUMPFLEX TERRAZZO 8	GRIT 1800	Ø 100mm - 4"	Velcro connection		€ 29,50
	T-KS 3	GRIT 60	Ø 100mm - 4"	Plastic support connection		€ 45,00
	T-KS 4	GRIT 120	Ø 100mm - 4"	Plastic support connection		€ 45,00
	T-KS 5	GRIT 220	Ø 100mm - 4"	Plastic support connection		€ 45,00
	T-KS 6	GRIT 400	Ø 100mm - 4"	Plastic support connection		€ 45,00
	T-KS 7	GRIT 800	Ø 100mm - 4"	Plastic support connection		€ 45,00
	T-KS 8	GRIT 1800	Ø 100mm - 4"	Plastic support connection		€ 45,00
	T-KS 3	GRIT 60	Ø 140mm - 5,5"	Velcro connection		€ 47,00
	T-KS 4	GRIT 120	Ø 140mm - 5,5"	Velcro connection		€ 47,00
	T-KS 5	GRIT 220	Ø 140mm - 5,5"	Velcro connection		€ 47,00
	T-KS 6	GRIT 400	Ø 140mm - 5,5"	Velcro connection		€ 47,00
	T-KS 7	GRIT 800	Ø 140mm - 5,5"	Velcro connection		€ 47,00
	T-KS 8	GRIT 1800	Ø 140mm - 5,5"	Velcro connection		€ 47,00
	COUGARFLEX TERRAZZO 3	GRIT 60	Ø 150mm - 6"	Velcro connection		€ 56,00
	COUGARFLEX TERRAZZO 4	GRIT 120	Ø 150mm - 6"	Velcro connection		€ 56,00
	COUGARFLEX TERRAZZO 5	GRIT 220	Ø 150mm - 6"	Velcro connection		€ 56,00
	COUGARFLEX TERRAZZO 6	GRIT 400	Ø 150mm - 6"	Velcro connection		€ 56,00
	COUGARFLEX TERRAZZO 7	GRIT 800	Ø 150mm - 6"	Velcro connection		€ 56,00
	COUGARFLEX TERRAZZO 8	GRIT 1800	Ø 150mm - 6"	Velcro connection		€ 56,00

COUGARFLEX TERRAZZO: Available also 100mm - 4" / 125mm - 5" / 140mm - 5,5"

Helix DIAMOND FLOOR PADS

HELIX DIAMOND FLOOR PADS

are an efficient solution for floor restoration and floor maintenance and provides very good results on polished concrete, natural stone, terrazzo, resin floors, etc.



Marble and Terrazzo polishing system - Start grinding the floor with HELIX grit 1 and 2 according to the condition of the floor, then proceed with HELIX grit 3 and 4. Use PADLUX floor pad and KS POLISH POWDER with little quantity of water to massage the floor until get the shine.

Old resin and epoxy coated floor restoration - (*High speed polishing machine like KP 43 DS DUAL SPEED is recommended*) Start scrubbing the floor with HELIX grit 0 or 1 according to the condition of the floor then proceed with HELIX grit 2 and 3. It is always suggested to work with little quantity of water at the medium speed of 200 rpm for about 60 sec/m². Polish with HELIX grit 4 working with little quantity of water at the higher speed of 400 rpm.

Matt finish ceramic, klinker and tiles heavy duty cleaning - (*not for polished tiles*) Start scrubbing the floor with HELIX grit 2 according to the condition of the floor, work at low speed of 160 rpm. Work wet with little quantity of water until old marks and dirty will disappear. Proceed with HELIX grit 4 and little quantity of water at low speed. Polish with HELIX grit 5 working at high speed 400 rpm.

Linoleum, PVC, Vinyl floor restoration - (*High speed polishing machine is recommended*) Start scrubbing the floor with HELIX grit 1 or 2 according to the condition of the floor, then proceed with HELIX grit 3. Work with little quantity of water at the medium speed of 200 rpm for about 60 sec/m². Then polish with HELIX grit 4 and little quantity of water at the higher speed of 400 rpm.



DESCRIPTION
<p>HELIX 000 Grit 60 Aggressive Grit. Suitable to remove deep marks or scratches on marble, concrete, natural stones and terrazzo.</p>
<p>HELIX 00 Grit 120 Suitable to remove deep marks or scratches on concrete, marble and natural stones.</p>
<p>HELIX 0 Grit 220 Suitable to remove light marks or light scratches on marble, concrete and natural stones.</p>
<p>HELIX 1 Grit 400 To use after HELIX 0 for a matt finish. It also remove light scratches on concrete, marble and natural stones.</p>
<p>HELIX 2 Grit 800 To use after HELIX 1 for a honed finish.</p>
<p>HELIX 3 Grit 1800 To use after HELIX 2 for a semi gloss finish.</p>
<p>HELIX 4 Grit 3500* To use after HELIX 3 for a gloss finish: Grit 4 is ideal for Buffing.</p>

*Available also
**HELIX 5 Grit 5000 and
HELIX 6 Grit 12000 Lux**

DESCRIPTION	SIZE	PRICE
HELIX 000 GRIT 60	240mm - 9,5"	€ 32,00
HELIX 00 GRIT 120	240mm - 9,5"	€ 32,00
HELIX 0 GRIT 220	240mm - 9,5"	€ 32,00
HELIX 1 GRIT 400	240mm - 9,5"	€ 32,00
HELIX 2 GRIT 800	240mm - 9,5"	€ 32,00
HELIX 3 GRIT 1800	240mm - 9,5"	€ 32,00
HELIX 4 GRIT 3500	240mm - 9,5"	€ 32,00
HELIX 000 GRIT 60	330mm - 13"	€ 39,50
HELIX 00 GRIT 120	330mm - 13"	€ 39,50
HELIX 0 GRIT 220	330mm - 13"	€ 39,50
HELIX 1 GRIT 400	330mm - 13"	€ 39,50
HELIX 2 GRIT 800	330mm - 13"	€ 39,50
HELIX 3 GRIT 1800	330mm - 13"	€ 39,50
HELIX 4 GRIT 3500	330mm - 13"	€ 39,50
HELIX 000 GRIT 60	430mm - 17"	€ 60,50
HELIX 00 GRIT 120	430mm - 17"	€ 60,50
HELIX 0 GRIT 220	430mm - 17"	€ 60,50
HELIX 1 GRIT 400	430mm - 17"	€ 60,50
HELIX 2 GRIT 800	430mm - 17"	€ 60,50
HELIX 3 GRIT 1800	430mm - 17"	€ 60,50
HELIX 4 GRIT 3500	430mm - 17"	€ 60,50
HELIX 000 GRIT 60	510mm - 20"	€ 79,00
HELIX 00 GRIT 120	510mm - 20"	€ 79,00
HELIX 0 GRIT 220	510mm - 20"	€ 79,00
HELIX 1 GRIT 400	510mm - 20"	€ 79,00
HELIX 2 GRIT 800	510mm - 20"	€ 79,00
HELIX 3 GRIT 1800	510mm - 20"	€ 79,00
HELIX 4 GRIT 3500	510mm - 20"	€ 79,00

Helix Plus DIAMOND FLOOR PADS

REVOLUTIONARY DIAMOND FLOOR PADS SUITABLE TO REMOVE SCRATCHES AND TO RESTORE THE GLOSS OF THE FLOORS.

Transforms your dull, worn floors into clean, glossy and brightly polished floors. Easy to use with standard single disc machine or with Orbital machines to remove scratches, cleaning and polishing the floors.

HELIX PLUS Diamond Floor Pads are an efficient solution for floor grinding, floor restoration and floor maintenance to provide a very good results on Concrete, Marble, Terrazzo, Ceramic, Klinker floors, Natural stone, PVC, Rubber, Vinyl, Epoxy and Wooden floors. HELIX PLUS Diamond Pads are available in several grits from Grit 50 to Grit 3500 and in 2 standard sizes 240mm/9,5" and 430mm/17".

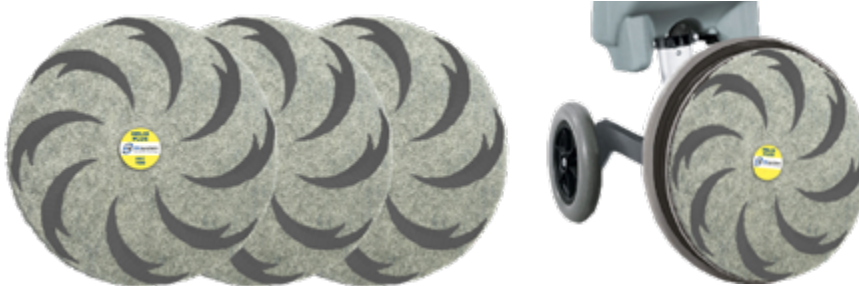

Suitable for
Single disc machines
and Orbital machines

ONLY WATER

HELIX PLUS can be used Wet or Dry. HELIX PLUS requires no chemical or wax. Cleaning and polishing using just water reduces the environmental impact and eliminates additional costs.



Using HELIX PLUS with a **planetary grinding machines** is possible to **polish and re-polish** all kind of floors. Suitable to remove deep scratches and restore acid, wine, cola stained, marble or terrazzo floors. HELIX PLUS are also suitable for grinding and polishing concrete floors.



Using HELIX PLUS instead of the traditional Floor Pads, allows to restore and maintain the floor always shine during the normal cleaning. For ordinary use, floor maintenance in large areas and also to polish old floors with **Single disc machines, Orbital Machines and auto-scrubbers**, getting results comparable to professional Floor Care Machines.

DESCRIPTION

HELIX PLUS 000 Grit 50

Aggressive Grit. Suitable to remove deep marks or scratches on marble, concrete and natural stones.

HELIX PLUS 00 Grit 100

Suitable to remove deep marks or scratches on concrete, marble and natural stones.

HELIX PLUS 0 Grit 200

Suitable to remove light marks or light scratches on marble, concrete and natural stones.

HELIX PLUS 1 Grit 400

To use after HELIX PLUS 0 for a matt finish. It also remove light scratches on concrete, marble and natural stones.

HELIX PLUS 2 Grit 800

To use after HELIX PLUS 1 for a honed finish.

HELIX PLUS 3 Grit 1500

To use after HELIX PLUS 2 for a semi gloss finish.

HELIX PLUS 4 Grit 3500

To use after HELIX PLUS 3 for a gloss finish: Grit 4 is ideal for Buffing.

DESCRIPTION		SIZE	PRICE
HELIX PLUS 000	GRIT 50	240mm - 9,5"	€ 32,00
HELIX PLUS 00	GRIT 100	240mm - 9,5"	€ 32,00
HELIX PLUS 0	GRIT 200	240mm - 9,5"	€ 32,00
HELIX PLUS 1	GRIT 400	240mm - 9,5"	€ 32,00
HELIX PLUS 2	GRIT 800	240mm - 9,5"	€ 32,00
HELIX PLUS 3	GRIT 1500	240mm - 9,5"	€ 32,00
HELIX PLUS 4	GRIT 3500	240mm - 9,5"	€ 32,00
HELIX PLUS 000	GRIT 50	430mm - 17"	€ 58,00
HELIX PLUS 00	GRIT 100	430mm - 17"	€ 58,00
HELIX PLUS 0	GRIT 200	430mm - 17"	€ 58,00
HELIX PLUS 1	GRIT 400	430mm - 17"	€ 58,00
HELIX PLUS 2	GRIT 800	430mm - 17"	€ 58,00
HELIX PLUS 3	GRIT 1500	430mm - 17"	€ 58,00
HELIX PLUS 4	GRIT 3500	430mm - 17"	€ 58,00



Hypershine STONE / EXTRA

HYPERSHINE STONE

Transforms your dull, worn floors into clean, glossy and brightly polished floors. Easy to use with standard single disc machine or with Orbital machines to remove scratches, cleaning and polishing the floors. Can be used with single disc machines to re-polish Marble and Terrazzo floors, getting results comparable to professional Floor Care Machines. Suitable to remove deep scratches and restore acid, wine, cola stained-floors.



HYPERSHINE EXTRA

Diamond Pads is available in several grits, can be used for Marble and Terrazzo, Ceramic and Klinker floors, Natural stone, PVC, Rubber, Vinyl, Epoxy and Wooden floors. Can be used with any type of floor care machines and auto-scrubber. Using HYPERSHINE EXTRA instead of the traditional Floor Pads, allows to restore and maintain the floor always shine during the normal cleaning.

Just water! HYPERSHINE EXTRA requires no chemical or wax. Cleaning and polishing using just water reduces the environmental impact and eliminates additional costs. Diamond floor pads designed for ordinary use and floor maintenance in large areas with single disc machines, Orbital Machines and auto-scrubbers. Used with Single disc and Orbital machines they can polish also old floors, ensuring optimal results, HYPERSHINE EXTRA can be used WET or DRY on most of common surfaces such as Marble, terrazzo, ceramic tiles, linoleum, vinyl and natural stone.



Old wood coating floor restoration

(KP 43 DS DUAL SPEED is recommended)

Start grinding the floor with HYPERSHINE EXTRA grit 1 or 2 according to the condition of the floor then proceed with HYPERSHINE EXTRA grit 3 and 4. Work dry at medium speed of 200 rpm until old marks and imperfection disappear.

Matt finish ceramic, klinker and glazed tiles heavy duty cleaning

(not for polished tiles).

Start scrubbing the floor with HYPERSHINE EXTRA grit 2 according to the condition of the floor, work at low speed of 160 rpm. Work wet with little quantity of water until old marks and dirty will disappear. Proceed with HYPERSHINE EXTRA grit 4 and little quantity of water at low speed. Polish with HYPERSHINE EXTRA grit 5 working at high speed 400 rpm.

Old resin and epoxy coated floor restoration

High speed polishing machine like KP 43 DS DUAL SPEED is recommended.

Start scrubbing the floor with HYPERSHINE EXTRA grit 0 or 1 according to the condition of the floor then proceed with HYPERSHINE EXTRA grit 2 and 3. It is always suggested to work with little quantity of water at the medium speed of 200 rpm for about 60 sec/m². Polish with HYPERSHINE EXTRA grit 4 working with little quantity of water at the higher speed of 400 rpm.

Marble and Terrazzo polishing system

Start grinding the floor with HYPERSHINE EXTRA grit 1 and 2 according to the condition of the floor, then proceed with HYPERSHINE EXTRA grit 3 and 4. Use PADLUX floor pad and KS POLISH POWDER with little quantity of water to massage the floor until get the shine.

Linoleum, PVC, Vinyl floor restoration

(High speed polishing machine is recommended)

Start scrubbing the floor with HYPERSHINE EXTRA grit 1 or 2 according to the condition of the floor, then proceed with HYPERSHINE EXTRA grit 3. Work with little quantity of water at the medium speed of 200 rpm for about 60 sec/m². Then polish with HYPERSHINE EXTRA grit 4 and little quantity of water at the higher speed of 400 rpm.



Hypershine STONE / EXTRA

HYPERSHINE STONE

Revolutionary Diamond Floor Pads suitable to remove scratches and restore the gloss on marble and terrazzo floors.

HYPERSHINE STONE can be used with single disc machines or with Orbital machines to re-polishing Marble and Terrazzo floors. Suitable to remove deep scratches and to restore scratched and stained-floors.

Start grinding the floor with HYPERSHINE STONE 00 or 0 in according to the condition of the floor, then proceed with HYPERSHINE STONE 1 and 2 (work with little quantity of water). Polish the floor with Polish Powder and Padluxe Floor Pad.



DESCRIPTION	SIZE	PRICE
HYPERSHINE STONE 000 GRIT 60	330mm - 13"	€ 52,00
HYPERSHINE STONE 00 GRIT 120	330mm - 13"	€ 52,00
HYPERSHINE STONE 0 GRIT 220	330mm - 13"	€ 52,00
HYPERSHINE STONE 1 GRIT 400	330mm - 13"	€ 52,00
HYPERSHINE STONE 2 GRIT 800	330mm - 13"	€ 52,00
HYPERSHINE STONE 3 GRIT 1800	330mm - 13"	€ 52,00
HYPERSHINE STONE 4 GRIT BUFF	330mm - 13"	€ 52,00
HYPERSHINE STONE 000 GRIT 60	430mm - 17"	€ 60,00
HYPERSHINE STONE 00 GRIT 120	430mm - 17"	€ 60,00
HYPERSHINE STONE 0 GRIT 220	430mm - 17"	€ 60,00
HYPERSHINE STONE 1 GRIT 400	430mm - 17"	€ 60,00
HYPERSHINE STONE 2 GRIT 800	430mm - 17"	€ 60,00
HYPERSHINE STONE 3 GRIT 1800	430mm - 17"	€ 60,00
HYPERSHINE STONE 4 GRIT BUFF	430mm - 17"	€ 60,00
HYPERSHINE STONE 000 GRIT 60	510mm - 20"	€ 75,00
HYPERSHINE STONE 00 GRIT 120	510mm - 20"	€ 75,00
HYPERSHINE STONE 0 GRIT 220	510mm - 20"	€ 75,00
HYPERSHINE STONE 1 GRIT 400	510mm - 20"	€ 75,00
HYPERSHINE STONE 2 GRIT 800	510mm - 20"	€ 75,00
HYPERSHINE STONE 3 GRIT 1800	510mm - 20"	€ 75,00
HYPERSHINE STONE 4 GRIT BUFF	510mm - 20"	€ 75,00

HYPERSHINE EXTRA

Transforms your dull floor into clean and polished floor. Easy to use with standard single disc machine or with Orbital machines to remove scratches, cleaning and polishing the floors.

HYPERSHINE EXTRA is available in 7 different grits, can be used for Concrete, Marble, Terrazzo, Ceramic, Klinker, Natural stone, PVC, Rubber, Vinyl, Epoxy and Wooden floors. HYPERSHINE EXTRA can be used Wet or Dry with any type of floor care machines and auto-scrubber. Using HYPERSHINE EXTRA instead of the traditional Floor Pads, allows to restore and keep the floor shine during the normal cleaning. HYPERSHINE EXTRA requires no chemical or wax. Using just water reduces the environment and eliminates additional costs.

DESCRIPTION

000 Grit 60

Aggressive Grit. Suitable to remove deep marks or scratches on marble, concrete and natural stones.

00 Grit 120

Suitable to remove deep marks or scratches on concrete, marble and natural stones.

0 Grit 220

Suitable to remove light marks or light scratches on marble, concrete and natural stones.

1 Grit 400

To use after HYPERSHINE EXTRA 0 for a matt finish. It also remove light scratches on concrete, marble and natural stones.

2 Grit 800

To use after HYPERSHINE EXTRA 1 for a honed finish.

3 Grit 1800

To use after HYPERSHINE EXTRA 2 for a semi gloss finish.

4 Grit BUFF*

To use after HYPERSHINE EXTRA 3 for a gloss finish: Grit 4 is ideal for Buffing.

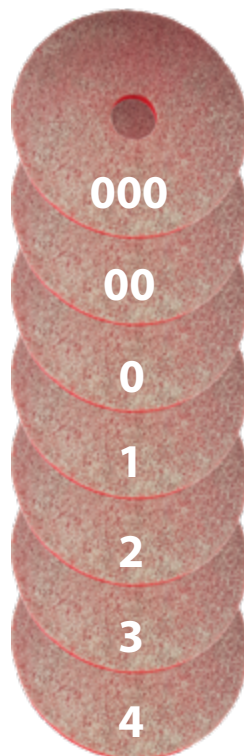

DESCRIPTION	SIZE	PRICE
HYPERSHINE EXTRA 000 GRIT 60	240mm - 9,5"	€ 48,00
HYPERSHINE EXTRA 00 GRIT 120	240mm - 9,5"	€ 48,00
HYPERSHINE EXTRA 0 GRIT 220	240mm - 9,5"	€ 48,00
HYPERSHINE EXTRA 1 GRIT 400	240mm - 9,5"	€ 48,00
HYPERSHINE EXTRA 2 GRIT 800	240mm - 9,5"	€ 48,00
HYPERSHINE EXTRA 3 GRIT 1800	240mm - 9,5"	€ 48,00
HYPERSHINE EXTRA 4 GRIT BUFF*	240mm - 9,5"	€ 48,00
HYPERSHINE EXTRA 000 GRIT 60	330mm - 13"	€ 55,00
HYPERSHINE EXTRA 00 GRIT 120	330mm - 13"	€ 55,00
HYPERSHINE EXTRA 0 GRIT 220	330mm - 13"	€ 55,00
HYPERSHINE EXTRA 1 GRIT 400	330mm - 13"	€ 55,00
HYPERSHINE EXTRA 2 GRIT 800	330mm - 13"	€ 55,00
HYPERSHINE EXTRA 3 GRIT 1800	330mm - 13"	€ 55,00
HYPERSHINE EXTRA 4 GRIT BUFF*	330mm - 13"	€ 55,00
HYPERSHINE EXTRA 000 GRIT 60	430mm - 17"	€ 70,00
HYPERSHINE EXTRA 00 GRIT 120	430mm - 17"	€ 70,00
HYPERSHINE EXTRA 0 GRIT 220	430mm - 17"	€ 70,00
HYPERSHINE EXTRA 1 GRIT 400	430mm - 17"	€ 70,00
HYPERSHINE EXTRA 2 GRIT 800	430mm - 17"	€ 70,00
HYPERSHINE EXTRA 3 GRIT 1800	430mm - 17"	€ 70,00
HYPERSHINE EXTRA 4 GRIT BUFF*	430mm - 17"	€ 70,00
HYPERSHINE EXTRA 000 GRIT 60	510mm - 20"	€ 90,00
HYPERSHINE EXTRA 00 GRIT 120	510mm - 20"	€ 90,00
HYPERSHINE EXTRA 0 GRIT 220	510mm - 20"	€ 90,00
HYPERSHINE EXTRA 1 GRIT 400	510mm - 20"	€ 90,00
HYPERSHINE EXTRA 2 GRIT 800	510mm - 20"	€ 90,00
HYPERSHINE EXTRA 3 GRIT 1800	510mm - 20"	€ 90,00
HYPERSHINE EXTRA 4 GRIT BUFF*	510mm - 20"	€ 90,00

*Available also

**HYPERSHINE EXTRA 5 Grit 5000 and
HYPERSHINE EXTRA 6 Grit 12000 Lux**

DIAMOND TOOLS AND SAND PAPER



SAND PAPER Ø 150

SAND PAPER Ø 430

MESH DISC

TYTAN DISC

DESCRIPTION		PRICE
	High quality abrasive sand paper. High performance. Suitable for floor preparation, concrete and wooden floors.	
	SAND PAPER GRIT 40 Ø 150mm – 6 BOX 200 pcs	€ 338,00
	SAND PAPER GRIT 60 Ø 150mm – 6 BOX 200 pcs	€ 298,00
	SAND PAPER GRIT 80 Ø 150mm – 6 BOX 200 pcs	€ 285,00
	SAND PAPER GRIT 100 Ø 150mm – 6 BOX 200 pcs	€ 255,00
	SAND PAPER GRIT 120 Ø 150mm – 6 BOX 200 pcs	€ 255,00
	High quality abrasive double face sand paper. Full resin bonded silicon carbide abrasive sand paper, for heavy duty applications. Suitable for concrete and wooden floors.	
	DOUBLE-SIDED SAND PAPER GRIT 16 Ø 430mm – 17" BOX 25 pcs	€ 550,00
	DOUBLE-SIDED SAND PAPER GRIT 24 Ø 430mm – 17" BOX 25 pcs	€ 512,50
	DOUBLE-SIDED SAND PAPER GRIT 36 Ø 430mm – 17" BOX 50 pcs	€ 795,00
	DOUBLE-SIDED SAND PAPER GRIT 60 Ø 430mm – 17" BOX 50 pcs	€ 575,00
	DOUBLE-SIDED SAND PAPER GRIT 80 Ø 430mm – 17" BOX 50 pcs	€ 525,00
	DOUBLE-SIDED SAND PAPER GRIT 100 Ø 430mm – 17" BOX 50 pcs	€ 525,00
DOUBLE-SIDED SAND PAPER GRIT 120 Ø 430mm – 17" BOX 50 pcs	€ 525,00	
	High quality abrasive screens impregnated with silicon carbide abrasive. Low clogging. Excellent finish. Applications: micro cement and wooden floors.	
	MESH DISC GRIT 60 Ø 406mm – 16" BOX 20 pcs	€ 206,00
	MESH DISC GRIT 80 Ø 406mm – 16" BOX 20 pcs	€ 206,00
	MESH DISC GRIT 120 Ø 406mm – 16" BOX 20 pcs	€ 206,00
	Carbide metal disc, double-sided, high performance, high wear-resistant abrasive lasts up to 150 times longer than sand paper and much more effective and time-saving. Suitable for removing a wide range of coatings on concrete, wooden and other surfaces. To be used with holder disc for sand paper.	
	TYTAN DISC COARSE Ø 430mm - 17" GRIT 14	€ 140,00
	TYTAN DISC MEDIUM Ø 430mm - 17" GRIT 24	€ 140,00
	TYTAN DISC FINE Ø 430mm - 17" GRIT 36	€ 140,00
	Floor preparation disc with metal tools to be used with orbital machines.	
	GRINDING PLATE WITH 3 TRAPEZOID TOOLS Ø 430mm – 17" GRIT 24	€ 290,00
	GRINDING PLATE WITH 3 TRAPEZOID TOOLS Ø 430mm – 17" GRIT 36	€ 290,00
	GRINDING PLATE WITH 6 TRAPEZOID TOOLS Ø 430mm – 17" GRIT 24	€ 435,00
	Jumpflex Marble Polishing Pads for Marble and Natural Stone.	
	JUMPFLEX MARBLE RESIN TOOLS Ø 75mm – 3" Available GRITS 50 - 100 - 200 - 400 - 800 - 1500 - 3500.	€ 24,00

DIAMOND BRUSHES AND ACCESSORIES

	DESCRIPTION	PRICE										
	<p>ABRASIVE BRUSHES Ø 100mm</p> <p>Abrasive diamond brushes gives an antique old-look effect on marble and natural stone floors. Can be used with marble, ceramic tiles, granite and concrete floors. Use wet or dry. Available GRIT 24 - 36 - 46 - 60 - 80 - 120 - 240 - 320 - 500 / Ø 100mm - 4" AS/Velcro connection.</p>	€ 40,00										
	<p>ABRASIVE BRUSHES Ø 240mm</p> <p>Abrasive diamond brushes gives an antique old-look effect on marble and natural stone floors. Can be used with marble, ceramic tiles, granite and concrete floors. Use wet or dry. Available GRIT 24 - 36 - 46 - 60 - 80 - 120 - 240 - 320 - 500 / Ø 240mm - 9,5". Velcro connection. # for heavy machines we recommend to use grits from 24 to 46.</p>	€ 175,00										
	<p>FULL AUTOMATIC INTELLIGENT GLOSSMETER</p> <p>Indispensable digital instrument of great precision to measure the degree of gloss on polished concrete, marble, granite, terrazzo and natural stone floors.</p> <ul style="list-style-type: none"> • Auto calibration • Auto start • Auto switch off • Easy charging system • Large display • Automatic data saving • Battery charger and professional blackcover bag included 	€ 880,00										
	<p>VELCRO PAD HOLDER Ø 240mm QUICK ATTACK</p> <p>Velcro Pad Holder for resin tools and pads.</p>	€ 78,00										
	<p>METAL PLATE HOLDER FOR TRAPEZOID TOOLS QUICK ATTACK</p> <p>Plate holder for trapezoid tools.</p>	€ 80,00										
	<p>PLASTIC VELCRO PAD HOLDER</p> <p>Plastic velcro support Ø 100mm.</p> <p>Plastic velcro support Ø 140mm.</p>	€ 21,00 € 26,50										
	<p>MOHS' HARDNESS PICK SET</p> <p>An essential tool for determining the concrete hardness (via scratch testing) and choosing the correct grinding tool!</p> <table border="1" data-bbox="491 1870 1177 2087"> <thead> <tr> <th>MOHS' SCALE</th> <th>Recommended metal bond tools</th> </tr> </thead> <tbody> <tr> <td>2-3</td> <td> Yellow bond for Soft Concrete</td> </tr> <tr> <td>3-5</td> <td> Grey bond for Medium Concrete</td> </tr> <tr> <td>5-7</td> <td> Red bond for Hard Concrete</td> </tr> <tr> <td>7-9</td> <td> Gold and White bond for Extra Hard Concrete</td> </tr> </tbody> </table>	MOHS' SCALE	Recommended metal bond tools	2-3	 Yellow bond for Soft Concrete	3-5	 Grey bond for Medium Concrete	5-7	 Red bond for Hard Concrete	7-9	 Gold and White bond for Extra Hard Concrete	€ 240,00
MOHS' SCALE	Recommended metal bond tools											
2-3	 Yellow bond for Soft Concrete											
3-5	 Grey bond for Medium Concrete											
5-7	 Red bond for Hard Concrete											
7-9	 Gold and White bond for Extra Hard Concrete											

LEVITEK 500 Grinder

MADE in ITALY



LEVITEK 500 GRINDER: planetary floor grinder fitted with a powerful motor max 2900 W - 4HP and the new planetary KS140. Suitable for grinding and polishing Marble, Concrete, Granite, Gres, Terrazzo and Wooden floors, ideal for apartments and industrial areas. Compact size machine ideal for working in smaller areas like bathrooms and kitchens. Also suitable for floor preparation and coating removal.

New and modern design made in Italy, Levitek 500 GRINDER is equipped with wide and no-slip wheels for easy transport and maneuverability. Ergonomic and adjustable handle allows comfortable and practical use of the machine. Wide range of accessories for any application.

TOOLING FOR FLOOR PREPARATION



GRINDING RING
12 SEGMENTS



GRINDING RING
16 SEGMENTS



GRINDING PLATE
6 TRAPEZOID

STEEL GEAR CONNECTION FOR PLANETARY KS140



EXTRA WEIGHT 17 KG included with the machine

APPLICATION

- Grinding and polishing marble, concrete, terrazzo and granite floors
- Suitable for floor preparation and coatings removal
- Also suitable for cleaning, maintenance and floor restoration

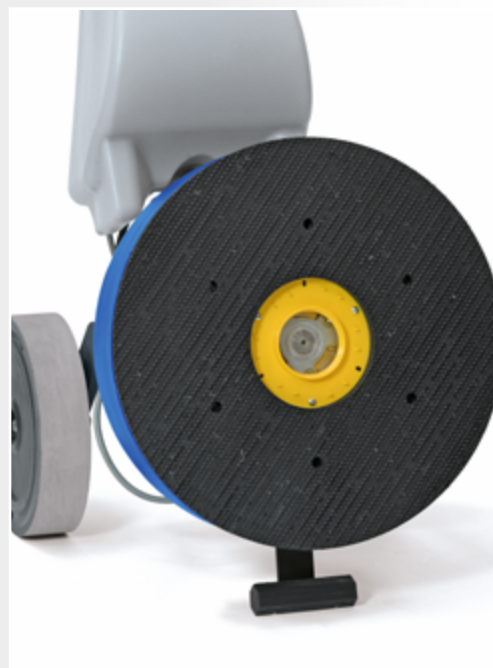

CONVERTIBLE IN SINGLE DISC MACHINE
SUITABLE FOR GRINDING AND POLISHING ANY KIND OF FLOOR

LEVITEK 500 Grinder



LEVITEK floor grinder is equipped with unidirectional removable full metal gear box planetary system. The removal of the planetarium from the floating head allows to transform Levitek from a powerful grinder to a performing single disc machine in few seconds. Levitek can use all type of diamond tools for any situation and it's compatible with all accessories for single disc machine. Levitek is 100% Made in Italy.

MAIN FEATURES

- Working width 510mm - 20"
- Tool holders 3x140mm / 5,5"
- Planetary rotation speed 160 rpm
- Tool speed 1000 rpm
- Quick connection system
- Helicoidal steel gears
- Planetary weight 12 kg



PLANETARY KS140 / 3 Heads

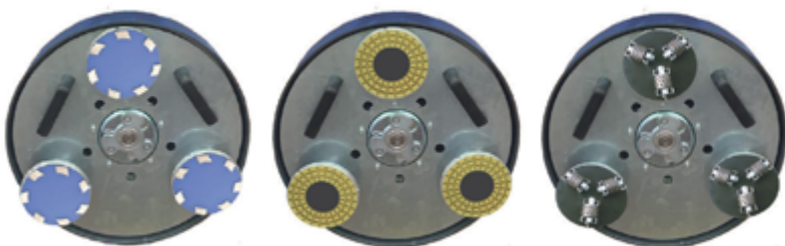

Suitable for grinding and polishing any kind of floor

Suitable also for bush-hammering
Kit bush-hammer 3x140mm / 5,5"

TECHNICAL DATA

Max Power	2900w - 4 Hp
Working Width	510 mm / 20"
Voltage	220-230 V / 50-60 Hz
Weight	115 Kg
Water Tank capacity	15 Lt
Price	€ 5.330,00

Includes: 1 weight 17 kg, Planetary KS140 (3 heads x140mm), water tank 15 Lt, cord extension and standard full velcro pad holder \varnothing 510mm.

LEVITEK 500 Sander

MADE in ITALY



LEVITEK 500 SANDER: planetary floor sander fitted with a powerful motor max 2900 W - 4HP and the new planetary KS140. Equipped with a special vacuum system on board, suitable for grinding and sanding wooden and prefinished floors. Ideal for wooden floor, parquet, concrete preparation and microcement floors. Compact size machine also suitable for working in medium and small size areas. Ideal for floor preparation and coatings removal.

New and modern design made in Italy. Wide no-slip wheels for easy transport and maneuverability. Ergonomic and adjustable handle allows comfortable and practical use of the machine. Wide range of accessories for any application.

MAIN ACCESSORIES

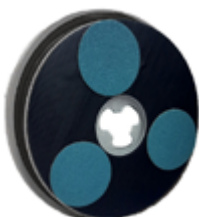

SAND PAPER DISC
Ø 150mm



GRINDING PLATE
Ø 510mm



STANDARD FULL VELCRO PAD HOLDER Ø 510mm

POWERFUL PLANETARY FLOOR SANDER EQUIPPED WITH VACUUM ON BOARD SUITABLE FOR GRINDING AND SANDING ANY KIND OF FLOORS



PLANETARY KS140 with 3 heads x 140 mm

APPLICATION

- Grinding and sanding wooden and prefinished floors
- Floor preparation
- Coating removal

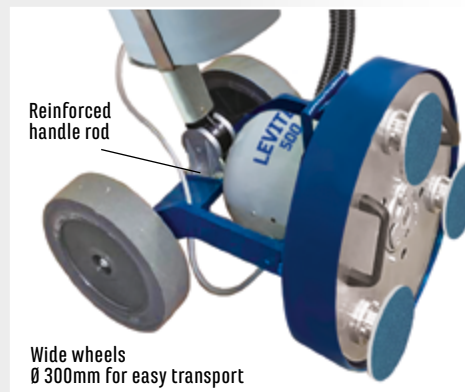

PLANETARY KS140 can be quickly removed to transform the machine in a powerful single disc machine.

TECHNICAL DATA

Max Power	2900w - 4 Hp
Working Width	510 mm / 20"
Voltage	220-230 V / 50-60 Hz
Weight	115 Kg
Water Tank capacity	15 Lt
Price	€ 6.005,00

Includes: 1 weight 17 kg, Planetary KS140 (3 heads x140mm), cord extension, pad holder for sand paper Ø 510mm, standard full velcro pad holder Ø 510mm, complete vacuum kit: vacuum cleaner, connection hose and rubber dust guard with connection.

PLANETARY KS140

NEW PLANETARY KS140 designed exclusively for Levitek 500, suitable for grinding and polishing Marble, natural stone, Terrazzo, Concrete and wooden floors. Very easy to install, thanks to its quick connection system. 3 or 4 rotating heads (140 mm / 5,5") allows to get high planarity and levelling the floor even on bad condition.

- The STEEL gear system of the Planetary KS140 doesn't need grease because it is self-lubricating.
- Planetary KS140 can be quickly removed to transform the machine in a single disc machine.

MAIN FEATURES:

- Tool speed 1000 rpm
- Working width 510mm - 20"
- Planetary weight 12 kg
- Tool holders 3 or 4 x140mm / 5,5"
- Planetary rotation speed 160 rpm
- Helicoidal steel gears
- Quick connection tool system

APPLICATIONS:

- Grinding and polishing all kind of surface
- Floor preparation and coatings removal
- Sanding wooden floors
- Bush-hammer

KS 140 / 3



KS 140 / 4



DESCRIPTION		PRICE	DESCRIPTION		PRICE
	VACUUM KIT complete with basket, dry vacuum cleaner with additional nylon filter and connection hose	€ 557,00		PLANETARY KS140 / 3 with 3 heads x140mm / 5,5". Suitable for Levitek 500. Working width 510mm - 20". Weight 12 kg.	€ 1.135,00
	CORD EXTENSION EU/UK PLUG 15 m power cord	€ 42,00		PLANETARY KS140 / 4 with 4 heads x140mm / 5,5". Suitable for Levitek 500. Working width 510mm - 20". Weight 12 kg.	€ 1.430,00
	WATER TANK 15 liter polyethylene tank	€ 110,00		PLASTIC VELCRO PAD HOLDER Ø 140mm - 5,5"	€ 26,50
	NYLON BRUSH Ø 510mm / 20"	€ 107,00		PLASTIC VELCRO PAD HOLDER Ø 140mm + RUBBER 5mm	€ 33,00
	FULL VELCRO AMORTIZED PAD HOLDER Ø 510mm / 20"	€ 110,00		SAND PAPER Ø 150mm - 6" Grit 40 / BOX 200 pcs	€ 389,00
	GROUTING DISC Ø 510mm / 20" for grouting jointed floors	€ 335,00		Grit 60 / BOX 200 pcs	€ 343,00
				Grit 80 / BOX 200 pcs	€ 330,00
				Grit 100-120 / BOX 200 pcs	€ 295,00
				BUSH-HAMMER Ø 140mm - 5,5" for bush-hammering, for preparing anti-slip surfaces and to remove thick resin coatings	€ 740,00
				GRINDING PLATE Ø 510mm - 20" with 6 trapezoid tools GRIT 24-36	€ 620,00

LEVITEK 450 Grinder

MADE in ITALY



POWERFUL PLANETARY FLOOR GRINDER
suitable for grinding and polishing any kind of floor

NEW PLANETARY KS100
with 3 heads x 100 mm

LEVITEK 450 GRINDER: planetary floor grinder fitted with a powerful motor max 2900 W - 4HP and the new planetary KS100. Suitable for grinding and polishing Marble, Concrete, Granite, Gres, Terrazzo and Wooden floors, ideal for apartments and industrial areas. Compact size machine ideal for working in smaller areas like bathrooms and kitchens. Also suitable for floor preparation and coating removal.

New and modern design made in Italy. Wide no-slip wheels for easy transport and maneuverability. Ergonomic and adjustable handle allows comfortable and practical use of the machine. Wide range of accessories for any application.

MAIN ACCESSORIES



GRINDING RING
12 segments



GRINDING RING
16 segments



FULL VELCRO PAD HOLDER



GRINDING PLATE



TYTAN DISC



BUSH-HAMMER

STEEL GEAR CONNECTION FOR PLANETARY KS100



EXTRA WEIGHT 17 KG included with the machine

APPLICATION

- Grinding and polishing marble, concrete, terrazzo and granite floors
- Suitable for floor preparation and coatings removal
- Also suitable for cleaning, maintenance and floor restoration

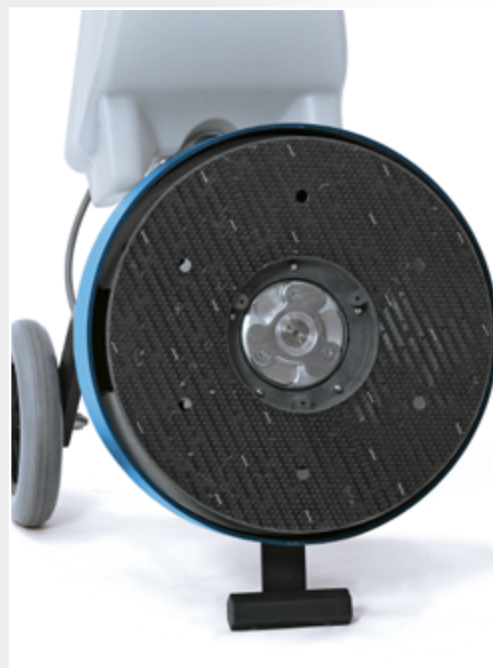

CONVERTIBLE IN SINGLE DISC MACHINE
SUITABLE FOR GRINDING AND POLISHING
ANY KIND OF FLOOR

LEVITEK 450 Grinder



LEVITEK floor grinder is equipped with unidirectional removable full metal gear box planetary system. The removal of the planetarium from the floating head allows to transform Levitek from a powerful grinder to a performing single disc machine in few seconds. Levitek can use all type of diamond tools for any situation and it's compatible with all accessories for single disc machine. Levitek is 100% Made in Italy.

MAIN FEATURES

- Working width 450mm - 18"
- Tool holders 3x100mm / 4"
- Planetary rotation speed 160 rpm
- Tool speed 1000 rpm
- Quick connection system
- Helicoidal steel gears
- Planetary weight 12 kg



QUICK RELEASE OF THE PLANETARY

The PLANETARY KS100 can be quickly removed to transform the machine in a powerful single disc machine

PLANETARY KS100 / 3 Heads



Suitable for grinding and polishing any kind of floor

TECHNICAL DATA

Max Power	2900w - 4 Hp
Working Width	450 mm / 18"
Voltage	220-230 V / 50-60 Hz
Weight	81 Kg
Water Tank capacity	15 Lt
Price	€ 5.085,00

Includes: 1 weight 17 kg, KS100 Planetary (3 heads x100mm), water tank 15 Lt, cord extension and standard full velcro pad holder Ø 450mm.

LEVITEK 450 Sander

MADE in ITALY



LEVITEK 450 SANDER: planetary floor grinder fitted with a powerful motor max 2900 W - 4HP and the new planetary KS100. Equipped with vacuum system on board, suitable for grinding and polishing any kind of floor. Ideal for floor grinding and preparation, glue, resin and coatings removal.

Compact size machine suitable for working in medium and small size areas. New and modern design made in Italy. Wide no-slip wheels for easy transport and maneuverability.

Ergonomic and adjustable handle allows comfortable and practical use of the machine. Wide range of accessories for any application.

MAIN ACCESSORIES

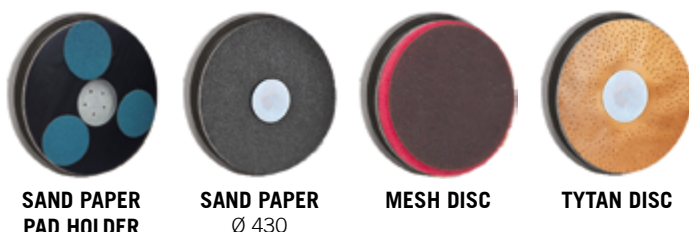

POWERFUL PLANETARY FLOOR SANDER EQUIPPED WITH VACUUM ON BOARD SUITABLE FOR GRINDING AND SANDING ANY KIND OF FLOORS



PLANETARY KS100 with 3 heads x 100 mm

APPLICATION

- Grinding and polishing any kind of floor
- Floor grinding and preparation
- Glue, resin and coatings removal

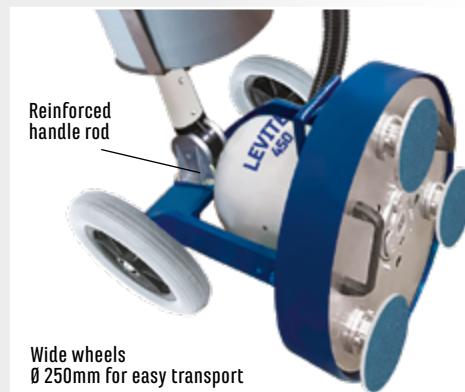

PLANETARY KS100 can be quickly removed to transform the machine in a powerful single disc machine.

TECHNICAL DATA

Max Power	2900w - 4 Hp
Working Width	450 mm / 18"
Voltage	220-230 V / 50-60 Hz
Weight	81 Kg
Water Tank capacity	15 Lt
Price	€ 5.695,00

Includes: 1 weight 17 kg, Planetary KS100 (3 heads x100mm), cord extension, pad holder for sand paper Ø 430mm, standard full velcro pad holder Ø 430mm, complete vacuum kit: vacuum cleaner, connection hose and rubber dust guard with connection.

PLANETARY KS100

New Planetary KS100 designed exclusively for Levitek 450, suitable for grinding and polishing Marble, natural stone, Terrazzo, Concrete and wooden floors. Very easy to install, thanks to its quick connection system. The 3 rotating heads (100 mm / 4") allows to get high planarity and levelling the floor even on bad condition.

- The gear system of the Planetary KS100 doesn't need grease because it is self-lubricating.
- Planetary KS100 can be quickly removed to transform the machine in a single disc machine.

MAIN FEATURES:

- Tool speed 1000 rpm
- Working width 450mm - 18"
- Planetary weight 12 kg
- Tool holders 3 x100mm / 4"
- Planetary rotation speed 160 rpm
- Helicoidal steel gears
- Quick connection tool system

APPLICATIONS:

- Grinding and polishing all kind of surface
- Floor preparation and coating removal
- Sanding wooden floors
- Bush-hammer



DESCRIPTION		PRICE	DESCRIPTION		PRICE
	VACUUM KIT complete with basket, dry vacuum cleaner with additional nylon filter and connection hose	€ 556,00		PLANETARY KS100 with 3 heads x100mm / 4" Suitable for Levitek 450. Working width 450mm - 18". Weight 12 kg.	€ 1060,00
	WATER TANK 15 liter polyethylene tank	€ 106,00		PLASTIC VELCRO PAD HOLDER Ø 100mm - 4"	€ 21,00
	NYLON BRUSH Ø 430mm / 17"	€ 53,00		DOUBLE-SIDED SAND PAPER Ø 430mm - 17" / Grit 16 / BOX 25 pcs Grit 24 / BOX 25 pcs Grit 36 / BOX 50 pcs Grit 60 / BOX 50 pcs Grit 80-100-120 / BOX 50 pcs	€ 550,00 € 512,50 € 795,00 € 575,00 € 525,00
	FULL VELCRO PAD HOLDER Ø 430mm / 17"	€ 95,00		MESH DISC Ø 406mm - 16" Grit 60-80-120-220 BOX 20 pcs	€ 206,00
	PAD HOLDER FOR SAND PAPER Ø 430mm / 17"	€ 112,00		TYTAN DISC Ø 430mm - 17" COARSE (Grit 14) / MEDIUM (Grit 24) FINE (Grit 36)	€ 129,00
	BUSH-HAMMER Ø 430mm / 17" for bush-hammering, for preparing anti-slip surfaces and to remove thick resin coatings	€ 1.440,00		GRINDING PLATE Ø 430mm - 17" with 6 trapezoid tools GRIT 24-36	€ 485,00

MAXI ORBITAL 430



MAXI ORBITAL 430 is an innovative single disc machine, suitable for heavy duty cleaning tasks. The machine uses an orbital movement which increases the productivity compared with a traditional single disc machine. By using high frequency oscillations, this machine offers excellent stability and maneuverability, despite a total weight of 65 kg, (not including accessories).

When working with water, the **MAXI ORBITAL 430** enables considerable savings as the water is constantly held within the disc area by the orbital movement, and is not dispersed.

In addition, the distinctive orbital movement makes it very easy for any operator to use the **MAXI ORBITAL 430** machine, reducing training times and eliminating the need for any particular degree of physical strength.

The low current absorption of this machine means that it can even be used together with a vacuum cleaner, with both appliances powered by standard mains voltage. **MAXI ORBITAL 430** enables several operations to be performed using the same machine, simply by changing the accessories.



Carpet cleaning

Daily floor maintenance



Coatings removal

Floor grinding and polishing

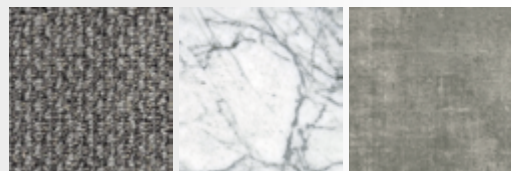

Carpet cleaning

Marble and Granite restoration

Concrete grinding and polishing

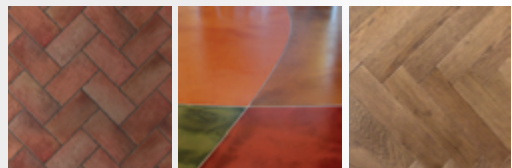

Ceramic, Terracotta and Klinker

Resin restoration and removal

Parquet sanding and restoration

TECHNICAL DATA

Drive	Direct Drive
Working width	430mm
Brush Ø	430mm
Pad holder Ø	430mm
Oscillations per minute n.	1400
Power supply	230 V 50/60 Hz*
Tank	15 Lt
Power	1100 W
Machine weight	65 Kg

*available also 120 V / 60 Hz



It used up to 1/10 the water of traditional single disc machines.

The consumption of chemicals is automatically reduced.

Working times and electricity consumption are reduced by around 40%

Less water, less detergent, less energy, less time, less manpower.

WHY CHOOSE A SINGLE DISC MACHINE WITH ROTO-ORBITAL SYSTEM?

- **Two movements in one: roto-orbital**

Simultaneous to the natural rotary movement of the disc, which can vary from 0 to 90 rpm, the system always generates a constant orbital movement that allows to pass very quickly over the same point many times. On surfaces such as hard floors, resilient floors, wood, resin and carpet floors, it creates rotational movements with a diameter of about 1 cm, with 1400 passes per minute. This guarantees an extraordinary and rapid scrubbing, polishing, crystallizing performance, etc. The innovative orbital technology guarantees an intense and delicate cleaning.

- **Perfect adhesion to the surface**

The working area is always constant and the brush/disc always remains level with respect to the surface, adhering perfectly.

- **Forward and backward movement and easy slewing**

The action of the brush is effective during any movement: forward and backward or slewing, staying flat on the surface at all times.

- **Less use of water and detergent**

The orbital movement holds the water inside the disc and is not sprayed outside. Thanks to this technology the consumption of water and consequently that of detergent is drastically reduced.

- **Low energy consumption**

Maximum absorption of 2,5-3 Ah.

- **A single machine for multiple functions**

The roto-orbital system ensures that all operations are carried out on various types of floor thanks to its versatility and the availability of specific accessories that make the machine multi-purpose.



MAXI ORBITAL 430 Sander

Thanks to the complete range of accessories and discs, **MAXI ORBITAL 430** satisfies the continuous requirements of the sanding world and more frequent demands for new finishes. Besides the traditional parquet sanding, by using sandpapers **MAXI ORBITAL 430** is exceptionally efficacious also on all the types of pre-finished parquet.

MAXI ORBITAL 430 can remove the varnish layer leaving entirely intact the noble part of the wood, in order to guarantee the chance of re-sanding other 2 or 3 times. **MAXI ORBITAL 430** does not leave signs and allows a good finishing since the first step. The following steps will allow the operator to save time guaranteeing an excellent result. The immense range of abrasives and diamond accessories of **MAXI ORBITAL 430** allow to perform the following works: resins and glue removal; floor sanding; floor polishing.



MAXI ORBITAL 430 SANDER including vacuum kit complete with basket, vacuum cleaner with additional nylon filter, connection hose and velcro dust guard with bristles. Ideal for wooden floor, parquet, concrete and microcement floors.

MAXI ORBITAL 430

**NEW
REVOLUTIONARY**

SINGLE DISC MACHINE
with
ROTO-ORBITAL SYSTEM



DESCRIPTION	MAXI ORBITAL 430 BASIC	MAXI ORBITAL 430 EXTRA*	MAXI ORBITAL 430 EXTRA* SANDER
Drive	Direct Drive	Direct Drive	Direct Drive
Working width	430mm - 17"	430mm - 17"	430mm - 17"
Power 230 V 50/60 Hz#	1100 W 1,5 Hp	1100 W 1,5 Hp	1100 W 1,5 Hp
Disc rotation speed	0-90 rpm	0-90 rpm	0-90 rpm
Oscillations / min.	1400	1400	1400
Brush Ø	430mm - 17"	430mm - 17"	430mm - 17"
Pad holder Ø	430mm - 17"	430mm - 17"	430mm - 17"
Tank capacity	15 Lt	15 Lt	15 Lt
Weight	65 Kg	65 Kg	65 Kg
Extra weight	17 Kg	17 Kg	17 Kg
PRICE	€ 1.955,00 Includes 1 weight 17 Kg	€ 2.205,00 Includes 1 weight 17 Kg	€ 2.670,00 Includes 1 weight 17 Kg + Vacuum Kit

*EXTRA: with quick release of the head from the trolley, quick unlock of the weight and fast disconnection of the electrical system.

Version available also with 120 V / 60 Hz

MAXI ORBITAL 430 EXTRA* SPRAY

Price € 2.345,00

in addition to the features of EXTRA*, Spray version it is equipped with a pump and 2 adjustable nozzles, a two-position switch and water tank.

ACCESSORIES MAXI ORBITAL 430

Price

* Cord extension EU/UK plug	€ 40,50
* Tank 15 Lt	€ 106,00
* Brush Ø 430mm - 17"	€ 72,00
* Standard full velcro Pad holder Ø 430mm - 17"	€ 112,00
Tynex brush gr 120	€ 214,00
Full velcro amortized Pad holder Ø 430mm - 17"	€ 94,00
Pad holder for steel wool Ø 430mm - 17"	€ 147,00
Pad holder for sand paper Ø 430mm - 17"	€ 157,00
Kit extra weight 17 Kg	€ 180,00
Complete vacuum kit + dry vacuum + rubber hood	€ 465,00
**** Complete standard kit Ø 430mm - 17"	€ 330,50



MAXI ORBITAL 500

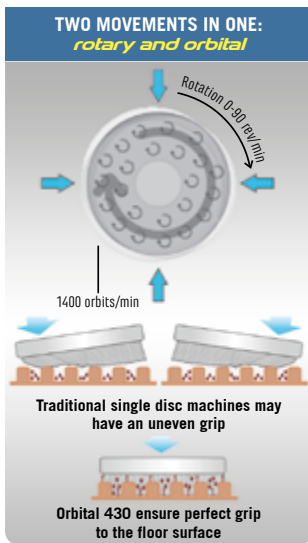

DESCRIPTION	MAXI ORBITAL 430 / 500 BASIC DUAL SPEED	MAXI ORBITAL 500 EXTRA*	MAXI ORBITAL 500 EXTRA* SPRAY
Drive	Direct Drive	Direct Drive	Direct Drive
Working width	430/500mm - 17"/20"	500mm - 20"	500mm - 20"
Power 230 V 50/60 Hz#	1100 W 1,5 Hp	1100 W 1,5 Hp	1100 W 1,5 Hp
Disc rotation speed	0-90/180 rpm	0-90 rpm	0-90 rpm
Oscillations / min.	1400/2800	1400	1400
Brush Ø	430/500mm - 17"/20"	500mm - 20"	500mm - 20"
Pad holder Ø	430/500mm - 17"/20"	500mm - 20"	500mm - 20"
Tank capacity	15 Lt	15 Lt	15 Lt
Weight	65 / 68 Kg	68 Kg	68 Kg
Extra weight	17 Kg	17 Kg	17 Kg
PRICE	500 Basic DS € 2.325,00 430 Basic DS € 2.320,00	€ 2.230,00 Includes 1 weight 17 Kg	€ 2.355,00 Includes 1 weight 17 Kg + Vacuum Kit

*EXTRA: with quick release of the head from the trolley, quick unlock of the weight and fast disconnection of the electrical system.

Version available also with 120 V / 60 Hz

MAXI ORBITAL 500 EXTRA* SPRAY: in addition to the features of EXTRA*, Spray version it is equipped with a pump and 2 adjustable nozzles, a two-position switch and water tank.



DUAL SPEED BUTTON

By pressing the DS Dual Speed button, the number of orbits changes from 1400 to 2800 orbits/min. This speed is recommended for dry polishing and crystallization operations.

PUMP FOR EXTRA SPRAY

Extra Spray version, with two adjustable nozzles. Uses a draw pipe with filter in the 15 liter solution tank.

ACCESSORIES MAXI ORBITAL 500

ACCESSORIES MAXI ORBITAL 500	Price
* Cord extension EU/UK plug	€ 40,50
* Tank 15 Lt	€ 106,00
* Nylon brush Ø 500mm - 20"	€ 90,00
* Full velcro amortized Pad holder Ø 500mm - 20"	€ 126,00
Standard full velcro Pad holder Ø 500mm - 20"	ND
Pad holder for steel wool Ø 500mm - 20"	ND
Pad holder for sand paper Ø 500mm - 20"	ND
Kit extra weight 17 Kg	€ 180,00
Complete vacuum kit + dry vacuum + rubber hood	€ 465,00
**** Complete standard kit Ø 500mm - 20"	€ 362,50

ORBITAL 430

It is not just a cleaning machine, but a cleaning system. Easy to use, it ensures high performance on every surface. It is easy to transport and to operate without tiring the operator. ORBITAL 430 SPRAY is provided with adjustable nozzles to control water consumption.

ORBITAL 430

ORBITAL 430 SPRAY



The Spray Kit is fitted on the ORBITAL 430 Spray version.

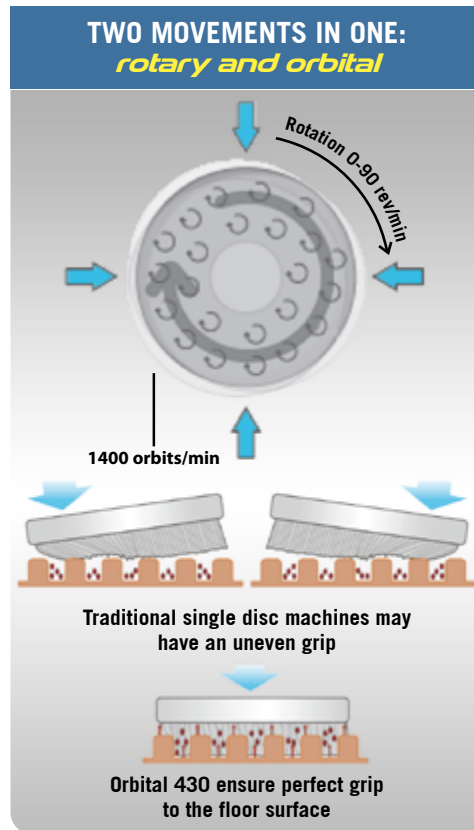

ORBITAL 430 is a newly devised single disc machine. Its rotary orbital motion improves performance compared to traditional single disc machines. Thanks to principle of high-frequency oscillations, excellent stability and maneuverability are ensured despite its total weight of 42 Kg.

During tasks requiring water, **ORBITAL 430** ensures considerable water savings as water is constantly kept within the disc area, without being dispensed. In addition to that, this peculiar orbital motion makes **ORBITAL 430** extremely user-friendly for any operator, with reduced times for technical training on the machine.

Thanks to its low consumption, it can also be used in combination with a vacuum cleaner, both being powered by a standard domestic mains supply. Through motion a vibration is created which ensures extraordinary cleaning, smoothing and polishing performance.

This innovative orbital technology ensures thorough and delicate cleaning. Each contact with the floor creates a 1 cm wide circular motion, with as many as 1400 rotations per minute. The cleaning effect increases, also other factors, such as time, water, chemicals and temperature, decrease drastically.



TECHNICAL DATA	ORBITAL 430	ORBITAL 430 SPRAY
Drive	Direct Drive	Direct Drive
Working width	430mm	430mm
Brush Ø	430mm	430mm
Pad holder Ø	430mm	430mm
Oscillations per minute n.	1400	1400
Power supply	230 V 50/60 Hz*	230 V 50/60 Hz*
Tank	15 Lt	15 Lt
Power	1100 W	1100 W
Machine weight	42 Kg	42 Kg

*available also 120 V / 60 Hz

ORBITAL 430

**NEW
REVOLUTIONARY**

**SINGLE DISC MACHINE
with
ROTO-ORBITAL SYSTEM**



DESCRIPTION	ORBITAL 430	ORBITAL 430 SPRAY*
Drive	Direct Drive	Direct Drive
Working width	430mm - 17"	430mm - 17"
Power 230 V 50/60 Hz#	1100 W 1,5	1100 W 1,5
Disc rotation speed	Hp	Hp
Oscillations / min.	0-90 rpm	0-90 rpm
Brush Ø	1400	1400
Pad holder Ø	430mm - 17"	430mm - 17"
Tank capacity	15 Lt	15 Lt
Weight	42 Kg	42 Kg
Extra weight	-	-
PRICE	€ 1.565,00 Includes cord extension, water tank, nylon brush and standard velcro pad holder	€ 1.805,00 Includes cord extension, water tank, nylon brush and standard velcro pad holder

*ORBITAL 430 SPRAY: is equipped with a pump and 1 adjustable nozzle, a two-position switch and water tank.

Version available also with 120 V / 60 Hz



3-POSITION BUTTON

Allows continuous, neutral or intermittent delivery.



SPRAY KIT

Equipped with pump, nozzle to adjust the spray of the solution and a control button on the handle. The Spray Kit is not supplied separately but fitted on the ORBITAL 430 Spray version.

ACCESSORIES ORBITAL 430

ACCESSORIES ORBITAL 430	Price
* Cord extension EU/UK plug	€ 40,50
* Tank 15 Lt	€ 106,00
* Nylon brush Ø 430mm - 17"	€ 81,00
* Standard full velcro Pad holder Ø 430mm - 17"	€ 112,00
Full velcro amortized Pad holder Ø 430mm - 17"	€ 94,00
Pad holder for steel wool Ø 430mm - 17"	€ 147,00
Pad holder for sand paper Ø 430mm - 17"	€ 157,00
**** Complete standard kit Ø 430mm - 17"	€ 340,00

ORBITAL PLUS⁺

Recommended for maintenance, deep cleaning, treatments and non-routine maintenance operations. Single or dual speed models for dry polishing and crystallization. Suction kit available for wood floor sanding.

ORBITAL PLUS

ORBITAL PLUS SANDER



ORBITAL PLUS models benefit the orbital mechanism to obtain optimal stability, ease of use and great maneuverability, even for no-expert operators. **ORBITAL PLUS** models with their weight of 50 kg and the option of connection to a vacuum unit, are suitable for a wider range of applications: dust-free sanding and restoration of wood floors, and reduced work times for smoothing and polishing marble. Ideal for washing, polishing, dewaxing, crystallization and restoration of marble floors, and for carpet washing.

ORBITAL PLUS has the benefits of orbital technology, such as: energy saving, water and detergent saving, and significant reduction of labor costs.

FLOOR TREATMENT FOR ANY KIND OF SURFACES

- Scrubbing
- Re-smoothing
- Polishing
- Crystallization

TECHNICAL DATA

Drive	Direct Drive	Power supply	230 V 50/60 Hz*
Working Width	430 mm	Tank	15 Lt
Brush Ø	430 mm	Power	1100 W
Oscillations per minute n.	1400	Machine weight	50 Kg



ORBITAL PLUS DUAL SPEED

The first speed is for washing, sanding, polishing and crystallization. The second speed greatly accelerates dry polishing and crystallization operations.



DUAL SPEED SWITCH

Changes the orbital speed from 1400 to 2800 oscillations per minute, the correct speed for dry polishing and floor crystallization treatments.



OPTIONAL SIDE CONNECTION CUFF

for vacuum kit. Simple insertion of vacuum hose.



3-POSITION BUTTON

Allows continuous, neutral or intermittent delivery.

ORBITAL PLUS⁺

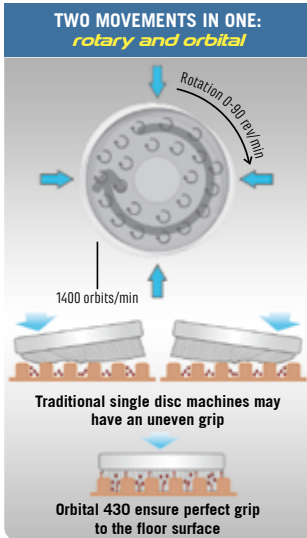

DESCRIPTION	ORBITAL PLUS BASIC	ORBITAL PLUS SPRAY	ORBITAL PLUS SANDER
Drive	Direct Drive	Direct Drive	Direct Drive
Working width	430mm - 17"	430mm - 17"	430mm - 17"
Power 230 V 50/60 Hz[#]	1100 W 1,5 Hp	1100 W 1,5 Hp	1100 W 1,5 Hp
Disc rotation speed	0-90 rpm	0-90 rpm	0-90 rpm
Oscillations / min.	1400	1400	1400
Brush Ø	430mm - 17"	430mm - 17"	430mm - 17"
Pad holder Ø	430mm - 17"	430mm - 17"	430mm - 17"
Tank capacity	15 Lt	15 Lt	15 Lt
Weight	50 Kg	51 Kg	50 Kg
PRICE	€ 1.650,00 Not includes any accessory	€ 1.850,00 With pump and adjustable nozzle, handle switch and tank	€ 2.115,00 Includes Vacuum Kit

*EXTRA: with quick release of the head from the trolley, quick unlock of the weight and fast disconnection of the electrical system.

Version available also with 120 V / 60 Hz



ORBITAL PLUS SANDER VACUUM KIT
complete with basket, vacuum cleaner with additional nylon filter, connection hose and velcro dust guard with bristles. Ideal for wooden floor, parquet, concrete and microcement floors.

ACCESSORIES	Price
* Cord extension EU/UK plug	€ 40,50
* Tank 15 Lt	€ 106,00
* Nylon brush Ø 430mm (0,45 mm)	€ 81,00
* Standard full velcro Pad holder Ø 430mm	€ 112,00
Full velcro amortized Pad holder Ø 430mm	€ 95,00
Pad holder for steel wool Ø 430mm	€ 147,00
Pad holder for sand paper Ø 430mm	€ 157,00
Vacuum kit + dry vacuum + rubber hood	€ 465,00
**** Complete standard kit Ø 430mm - 17"	€ 340,00

SINGLE DISC MACHINES

Easy Line

Easy Line KP43 is a Single Disc Machines Line very solid and easy maintenance. With a stainless steel shell and PPL upholstery, they combine efficiency and versatility together with a modern ergonomics. Just model KP43G can be equipped with a 7 Kg extra weight code 224889, upon request. Moreover, the removable power cable makes transport and maintenance easier.



Ergonomic and user friendly



Affordable



Robust



Versatile



Quiet



The off-set position of the engine ensures a well-balanced weight distribution.

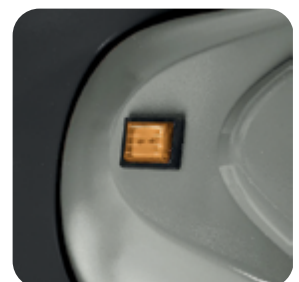

Available also the **KP43 DS** 180 or 400 rpm dual speed version.



Adjustable handle for the best operating posture.



Protection for drive system.



Water distribution in the middle.

TECHNICAL DATA	KP 43 160 rpm	KP 43 180 rpm	KP 43 400 rpm	KP 43 DS 2 speed
Drive	Nylon gear	Belt	Belt	Belt
Rated power 230V 50/60Hz*	1100 W	1100 W	1400 W	1250/1700 W
Rated power	1,5 Hp	1,5 Hp	2 Hp	2,5 Hp
Speed	160 rpm	180 rpm	400 rpm	180/400 rpm
Brush Ø	430mm	430mm	430mm	430mm
Pad holder Ø	430mm	430mm	430mm	430mm
Tank capacity	15 Lt	15 Lt	15 Lt	15 Lt
Weight	35 Kg	35 Kg	35 Kg	35 Kg
Extra weight	7 Kg	-	-	-

*available also 120 V / 60 Hz

KF 43



KF 33



KS 43 PLUS



► Heavy Line recommended for **HEAVY DUTY WORKS**

KF 43 and **KF 33** has a steel shell and combines an high power motor with very compact dimensions, in order to grant a excellent finishing even in narrow spaces. Highly versatile.

Working size 330mm or 430mm.

KS 43 PLUS models have an aluminum base for a better resistance to chemicals and a steel gear box. Upon request each machine can be equipped with extra weight of 2 Kg (kit code 224932), and the removable power cable makes transport and maintenance easier.

Working size 430mm. KS 43 PLUS is available:

1100 W - 1,5 Hp / 1800 W - 2,5 Hp / 2200 W - 3 Hp

Nylon gear drive for **KF 43** and **KF 33**



Steel gear drive for **KS 43 PLUS**

TECHNICAL DATA	KF 43	KF 33	KS 43 PLUS
Drive	Nylon gear	Nylon gear	Steel gear
Rated power 230V 50/60Hz*	1100 W	1100 W	1100/1800/2200 W
Rated power	1,5 Hp	1,5 Hp	1,5/2,5/3,0 Hp
Speed	160 rpm	160 rpm	160 rpm
Brush Ø	430mm	330mm	430mm
Pad holder Ø	430mm	330mm	430mm
Tank capacity	15 Lt	15 Lt	15 Lt
Weight	42 Kg	35 Kg	42 Kg
Extra weight	4 Kg	-	2 Kg

*available also 120 V / 60 Hz

SINGLE DISC MACHINES

Heavy Line

KS 50 PLUS



K UHS 1500 V



High Speed
Polisher
1500 rpm



► Heavy Line recommended for HEAVY DUTY WORKS

KS 50 PLUS model have an aluminum base for a better resistance to chemicals and a steel gear box. Upon request each machine can be equipped with extra weights up to 4 Kg, and the removable power cable makes transport and maintenance easier.

Working size 510mm. KS 50 PLUS is available:
1100 W - 1,5 Hp / 1800 W - 2,5 Hp / 2200W - 3 Hp



Steel gear drive for **KS 50 PLUS**

KS 50 PLUS, extra weights can be added to enhance scrubbing performance



K UHS 1500 V Dust control available

K UHS 1500 V is a high speed polisher that offers developed technological solutions to improve performance and comfort of the operator. The base is counterbalanced by a gas spring that improves the contact between disc's surface and floor, getting rid of the need of any inconvenience that might be caused by a front wheel. In this way the handle, free of any constraint, offers the operator a remarkable comfort when working. The removable power cable makes transport and maintenance easier.

Working size 510mm.

TECHNICAL DATA	KS 50 PLUS	K UHS 1500 V
Drive	Steel gear	Direct Drive
Rated power 230V 50/60Hz*	1100/1800/2200 W	1100 W
Rated power	1,5/2,5/3,0 Hp	1,5 Hp
Speed	160 rpm	1500 rpm
Brush Ø	510mm	-
Pad holder Ø	510mm	510mm
Tank capacity	15 Lt	-
Weight	45 Kg	38 Kg
Extra weight	4 Kg	-

*available also 120 V / 60 Hz

SINGLE DISC MACHINES



KP 43

KP 43 G

KF 33

KF43 / KS 43 PLUS

KS 50 PLUS

**K UHS 1500 V/S
High Speed polisher**

KP · Stainless steel shell and Ppl upholstery

KF · Steel shell

KS · Aluminum base

Easy Line

DESCRIPTION	KP 43 G 160 rpm	KP 43 180 rpm	KP 43 400 rpm	KP 43 DS dual speed
Drive	Nylon gear	Belt	Belt	Belt
Speed	160 rpm	180 rpm	400 rpm	180/400 rpm
Rated power 230 V 50/60 Hz*	1100 W 1,5 Hp	1100 W 1,5	1400 W 2 Hp	1250/1700 W 2,5
Brush Ø	430mm	Hp	430mm	Hp
Pad holder Ø	430mm	430mm	430mm	430mm
Tank capacity	15 Lt	15 Lt	15 Lt	15 Lt
Weight	35 Kg	35 Kg	35 Kg	35 Kg
Extra weight	7 Kg	-	-	-
PRICE (accessories not included)	€ 956,00	€ 920,00	€ 1.060,00	€ 1.278,00

* Version available also with 120 V / 60 Hz

Heavy Line

DESCRIPTION	KF 33	KF 43	KS 43 PLUS	KS 50 PLUS	K UHS 1500 S/V
Drive	Nylon gear	Nylon gear	Steel gear	Steel gear	Direct Drive
Speed	160 rpm	160 rpm	160 rpm	160 rpm	1500 rpm
Rated power 230 V 50/60 Hz*	1100 W 1,5 Hp	1100 W 1,5 Hp	a) 1100 W 1,5 Hp b) 1800 W 2,5 Hp c) 2200 W 3,0 Hp	a) 1100 W 1,5 Hp b) 1800 W 2,5 Hp c) 2200 W 3,0 Hp	1100 W 1,5 Hp
Brush Ø	330mm	430mm	430mm	510mm	-
Pad holder Ø	330mm	430mm	430mm	510mm	510mm
Tank capacity	15 Lt	15 Lt	15 Lt	15 Lt	-
Weight	35 Kg	42 Kg	42 Kg	45 Kg	38 Kg
Extra weight	-	4 Kg	2 Kg	4 Kg	-
PRICE (accessories not included)	€ 1.022,00	€ 1.060,00	a) € 1.425,00 b) € 1.585,00 c) € 1.698,00	a) € 1.475,00 b) € 1.638,00 c) € 1.755,00	S € 2.057,00 V € 2.178,00 pad holder included

* Version available also with 120 V / 60 Hz

ACCESSORIES	Price	ACCESSORIES	Price
* Cord extension EU/UK plug	€ 40,50	Nylon brush Ø 330mm	€ 51,00
* Nylon brush Ø 430mm	€ 51,00	Standard velcro Pad holder Ø 330mm	€ 81,00
* Tank 15 Lt	€ 106,00	Pad holder for sand paper Ø 430mm	€ 111,00
* Standard velcro Pad holder Ø 430mm	€ 93,50	**** Complete standard kit Ø 430mm	€ 291,00

Professional Vacuum

Compact Extra



XP 530 WD

XP 560 WD

XP 580 WD

XP 7110.2 WD
XP 7110.3 WD

XP 5110.2 WD*
XP 5110.3 WD*

Professional vacuum cleaners equipped with **ROTATIONAL POLYPROPYLENE DRUM**. This specific and very robust tank guarantees strength and durability over time. Available Wet & Dry versions, with 1, 2 and 3 motors, to meet every cleaning need. Capacity tank 30 Lt, 60 Lt, 80 Lt up to 110 Lt. Applications: general cleaning sector, also suitable for heavy applications.

Pro Team Extra Line is specifically made to collect large quantities of water and mud especially those created during floor grinding procedures. Ideal to connect with grinding and polishing machines working "wet system" and with drilling machines.



SHIFT & CLEAN

Special filter cleaning system with "REVERSE FLOW" for saving time of the operator who does not have to open the machine for this indispensable maintenance operation.

System equipped for models:
XP 5110.2 WD and XP 5110.3 WD



Kit Wet & Dry Ø 37mm code 225438

Kit Wet & Dry Ø 40mm code 225439



Traditional poly filters washable + cartridge optional.

TECHNICAL DATA

MODEL	Type	Motor num.	Max Power	Voltage - Frequency	Air flow l/s	Water lift mmH2O	Capacity	Price
XP 530 WD	W&D	1	1100 W	230-240 V - 50/60 Hz	54	2400	30 Lt	€ 408,00
XP 560 WD	W&D	1	1100 W	230-240 V - 50/60 Hz	54	2400	60 Lt	€ 417,00
XP 580 WD	W&D	1	1100 W	230-240 V - 50/60 Hz	54	2400	80 Lt	€ 585,00
XP 7110.2 WD	W&D	2	2200 W	230-240 V - 50/60 Hz	108	2400	110 Lt	€ 762,00
XP 7110.3 WD	W&D	3	3300 W	230-240 V - 50/60 Hz	148	2400	110 Lt	€ 821,00
XP 5110.2 WD*	W&D	2	2200 W	230-240 V - 50/60 Hz	108	2400	110 Lt	€ 792,00
XP 5110.3 WD*	W&D	3	3300 W	230-240 V - 50/60 Hz	148	2400	110 Lt	€ 850,00

Professional Vacuum

Proteam Line



P 711 D
P 511 WD



P 712 D
P 512 WD



P 525 WD



P 527 WD



P 540 WDM



P 750.2 WDM S*
P 750.3 WDM S*

Plast



A 711 D
A 511 WD



A 527 WD



A 750.2 WD



A 750.2 WDM S*
A 750.3 WDM S*



FRONT MOUNTED KIT SQUEEGEE

The front fixed squeegee accessory is also available to easily suck up liquids on large surfaces.

COD. 226890 - € 394,00

Inox

Professional vacuum cleaners available with polypropylene or stainless steel tank. Capacity tank from 22 Lt to 66 Lt. 1-2-3 motors. Dry and Wet & Dry versions to meet every cleaning need. Versions available with fixed trolley or market version. Standard front hose drain kit to facilitate emptying operations for WDM trolley version. Traditional poly filters washable + cartridge optional.



TECHNICAL DATA

MODEL *S: HOSE DRAIN KIT	Type	Motor num.	Max power	Stages	Air flow l/s	Water lift mm H2O	Capacity tank	Accessories included	Price
PLASTIC TANK									
P 711 D	DRY	1	800 W	single	40	2200	22 Lt	Kit Ø 37mm	€ 252,00
P 711 D 1200 W	DRY	1	1200 W	double	54	2400	22 Lt	Kit Ø 37mm	€ 254,00
P 511 WD	W&D	1	1200 W	double	54	2400	22 Lt	Kit Ø 37mm	€ 297,00
P 712 D	DRY	1	800 W	single	54	2200	25 Lt	Kit Ø 37mm	€ 237,00
P 712 D 1200 W	DRY	1	1200 W	double	54	2400	25 Lt	Kit Ø 37mm	€ 239,00
P 512 WD	W&D	1	1200 W	double	54	2400	25 Lt	Kit Ø 37mm	€ 271,00
P 525 WD	W&D	1	1200 W	double	54	2400	35 Lt	Kit Ø 37mm	€ 285,00
P 527 WD	W&D	1	1200 W	double	54	2400	35 Lt	Kit Ø 40mm	€ 312,00
P 540 WDM	W&D	1	1200 W	double	54	2400	60 Lt	Kit Ø 40mm	€ 448,00
P 750.2 WDM S*	W&D	2	2400 W	double	108	2400	65 Lt	Kit Ø 40mm	€ 544,00
P 750.3 WDM S*	W&D	3	3300 W	double	148	2400	65 Lt	Kit Ø 40mm	€ 603,00
INOX TANK									
A 711 D	DRY	1	800 W	single	40	2200	22 Lt	Kit Ø 37mm	€ 278,00
A 711 D 1200 W	DRY	1	1200 W	double	54	2400	22 Lt	Kit Ø 37mm	€ 279,00
A 511 WD	W&D	1	1200 W	double	54	2400	22 Lt	Kit Ø 37mm	€ 323,00
A 527 WD	W&D	1	1200 W	double	54	2400	35 Lt	Kit Ø 40mm	€ 333,00
A 750.2 WD	W&D	2	2400 W	double	108	2400	66,5 Lt	Kit Ø 40mm	€ 508,00
A 750.2 WDM S*	W&D	2	2400 W	double	108	2400	66,5 Lt	Kit Ø 40mm	€ 575,00
A 750.3 WDM S*	W&D	3	3300 W	double	148	2400	66,5 Lt	Kit Ø 40mm	€ 634,00

Professional Vacuum



QUICK Professional vacuum cleaners with “QUICK CLEAN SYSTEM“ to clean perfectly the filter without opening the vacuum. Standard M class filter cartridge fitted inside the head, not in contact with liquids. This allows the operator to work no-stop and suck up solids and liquids.



QUICK CLEAN SYSTEM

TECHNICAL DATA						
MODEL	Type	Motor num.	Max power	Capacity tank	Accessories included	Price
QUICK P12	W&D	1	1200 / 1400 W	25 Lt	Kit Ø 37mm	€ 305,00
QUICK P25	W&D	1	1200 / 1400 W	35 Lt	Kit Ø 40mm	€ 325,00
QUICK P35	W&D	1	1600 / 1800 W	45 Lt	Kit Ø 40mm	€ 359,00
QUICK A11	W&D	1	1200 / 1400 W	22 Lt	Kit Ø 37mm	€ 331,00
QUICK A27	W&D	1	1200 / 1400 W	35 Lt	Kit Ø 40mm	€ 353,00
QUICK P30	W&D	1	1200 / 1400 W	25 Lt	Kit Ø 37mm	€ 422,00
QUICK P60	W&D	1	1200 / 1400 W	43 Lt	Kit Ø 40mm	€ 429,00
QUICK P80	W&D	1	1600 / 1800 W	80 Lt	Kit Ø 40mm	€ 606,00

INJECTION / EXTRACTION

Multifunctional injection/extraction machines, powerful and versatile. They can be also used as wet & dry vacuum cleaners. The high capacity tanks allow a quick and continuative use.

TECHNICAL DATA				
MODEL	Type	Capacity tank	Accessories included	Price
EXTRACT P12	W&D	12 Lt	Kit Ø 37mm	€ 480,00
EXTRACT P25	W&D	25 Lt	Kit Ø 37mm	€ 497,00
EXTRACT TOP A27	W&D	25 Lt	Kit Ø 40mm	€ 455,00
EXTRACT A58.3 DP	W&D	58 Lt	Kit Ø 40mm	€ 843,00
EXTRACT A58.3	W&D	58 Lt	Kit Ø 40mm	€ 1.035,00
EXTRACT TOP CAR	W&D	58 Lt	Kit Ø 40mm	€ 795,00



Extract P12
Extract P25

Extract A58.3 DP
Extract A58.3
Extract TOP CAR

TOP P80 / P100

Special vacuum cleaners equipped with considerable robustness polyethylene tank. High resistance to chemical agents and impacts. Equipped with an extraction pump with float that can be activated by the operator or automatically when the liquid reaches a certain level. Special filter separates liquids from any solid waste. With a flow rate of 250 Lt/min it enables continuous emptying operations. Kit WET/A diam.40 included.



TECHNICAL DATA	TOP P80 WD/PE	TOP P100 WD/PE
Type	Wet	Wet
Barrel material	phed	phed
Power	230/240 V - 50/60 Hz	230/240 V - 50/60 Hz
Motor - Stages n.	1 - 2	1 - 2
Rated power	1950 W	1950 W
Vacuum - Air flow	25 kPa - 59 l/s	25 kPa - 59 l/s
Pump water flow	250 l/m	250 l/m
Total barrel capacity	80 Lt	100 Lt
Noise level	70 dB	70 dB
Price	€ 1.130,00	€ 1.190,00

Professional Vacuum



Basic Standard P / FLY



Basic New / Plus New



Plus Silenzio



Inox



PLUS HC

PICCOLO BASIC / BASIC NEW Small, robust, extremely compact and silent 60 Db. **STANDARD P** Powerful (290 mBar), 61 dB. Full bag alarm, cartridge filter and additional electrical socket. **PLUS - PLUS NEW - PLUS HC** Practical accessories holder, drawer filter and the detachable cable. **SILENZIO** Equipped with power regulator to the crease the noise level. **FLY** Dedicated to the cleaning of aircraft because it directly uses the power available on aircraft (115 V, 440 Hz) without having to use external generators. **INOX** Metal flat cover and stainless steel tank, practical accessories holder, drawer filter and the detachable cable.

TECHNICAL DATA

MODEL	Type	Motor num.	Max power	Voltage; Frequency	Capacity tank	Gross weight	Accessories included	Price
BASIC	DRY	1	800/900 W	230-240 V; 50/60 Hz	13 Lt	7 Kg	Kit Ø 32mm	€ 191,00
STANDARD P	DRY	1	800/900 W	230-240 V; 50/60 Hz	13 Lt	7 Kg	Kit Ø 37mm	€ 230,00
FLY	DRY	1	1200/1400 W	120 V; 400 Hz	13 Lt	7,5 Kg	Kit Ø 32mm	€ 278,00
BASIC NEW	DRY	1	800/900 W	230-240 V; 50/60 Hz	13 Lt	7 Kg	Kit Ø 32mm	€ 196,00
PLUS NEW	DRY	1	800/900 W	230-240 V; 50/60 Hz	13 Lt	7 Kg	Kit Ø 37mm	€ 269,00
PLUS	DRY	1	800/900 W	230-240 V; 50/60 Hz	13 Lt	7 Kg	Kit Ø 37mm	€ 247,00
SILENZIO	DRY	1	900/500 W	230-240 V; 50/60 Hz	13 Lt	7 Kg	Kit Ø 32mm	€ 292,00
INOX	DRY	1	800/900 W	230-240 V; 50/60 Hz	15 Lt	7,5 Kg	Kit Ø 32mm	€ 376,00
PLUS HC	DRY	1	800/900 W	230-240 V; 50/60 Hz	25 Lt	8 Kg	Kit Ø 37mm	€ 252,00

DRYVER Vacuum cleaners with excellent performances; equipped with tanks from 10 and 15 Lt. On/Off switch by foot, the teachable cable and noiseless are the main features of this product. A series of technical devices make them unique on the market, while the series filtration system returns pure air to the environment.

• Dryver "RE" Version "energy saver" mode to increase/decrease the power of the motor.



TECHNICAL DATA

MODEL	Type	Motor num.	Max power	Voltage; Frequency	Capacity tank	Gross weight	Accessories included	Price
DRYVER 10 R	DRY	1	700/800 W	230-240 V; 50/60 Hz	10 Lt	10 Kg	Kit Ø 32mm	€ 232,00
DRYVER 10 RE	DRY	1	700/800 W	230-240 V; 50/60 Hz	10 Lt	11 Kg	Kit Ø 32mm	€ 254,00
DRYVER 15 R	DRY	1	700/800 W	230-240 V; 50/60 Hz	15 Lt	10 Kg	Kit Ø 32mm	€ 239,00
DRYVER 15 RE	DRY	1	700/800 W	230-240 V; 50/60 Hz	15 Lt	10 Kg	Kit Ø 32mm	€ 260,00

ATOM

Practical and economic professional vacuums. High quality with removable and washable cartridge filter, protected by the entrance of the dust in order to avoid fast dogging.

ATOM: dry version.

ATOM PLUS: wet and dry version. Guarantee excellent value for money.



Atom

Atom Plus

TECHNICAL DATA

	ATOM	ATOM PLUS
Type	Dry	Wet/Dry
Barrel material	PPL	PPL
Power	230 V / 50 Hz	230 V / 50 Hz
Motor - Stages n.	1 - 1	1 - 1
Rated power	700/900 W	1200/1350 W
Air flow (cm / h)	102	120
Total barrel capacity	10 Lt	20 Lt
Cable length	4,5 m	4,5 m
Weight	4,2 Kg	6 Kg
Price	€ 99,00	€ 102,00

POWERVAK Boost

INDUSTRIAL VACUUMS WITH HEPA D.O.P.14 FILTERS AND MANUAL FILTERS CLEANING

POWERVAK BOOST 101 - 202 - 303 industrial vacuums with HEPA certification D.O.P. 14 designed to satisfy those customers looking for a competitive industrial vacuum with **compact dimensions, good suction performance and the best filtration system**. The advantages in terms of filtration and suction performance are evident, thanks to the **double filtration system** (Primary filtration with HEPA cartridge + PTFE membrane without bottom plate + Secondary Filtration Certified HEPA D.O.P. 14). With the installation of 1, 2 or 3 HEPA D.O.P. secondary filters (depending on the model) the dust filtration quality is absolute, representing an additional safety factor for the operator.

The new design of Powervak Boost, with the **motors installed in the rear, in the lower part**, has allowed us to have an industrial vacuum cleaner with reduced dimensions, with an excellent maneuverability and **easy transport**. Furthermore, the center of gravity, shifted lower, makes the industrial vacuum more stable.

- ▶ New manual Boost filter cleaning system using pressure differential designed for fine dust
- ▶ New primary Hepa cartridge filter with PTFE membrane designed without bottom plate for a perfect discharge of dust from filters and filter cleaning
- ▶ New certified secondary Hepa D.O.P. 14 filtration for highest filtration performance
- ▶ With Longopac® continuous bag dust collecting system
- ▶ Compact design for easy transport and maneuverability



Boost 303



MANUAL CLEANING

POWERVAK Boost 101



FILTER SYSTEM

Cartridge filter with an innovative design, **without lower bottom** to ensure perfect dust discharge from the filter once cleaned.



DIFFERENTIAL PRESSURE CLEANING SYSTEM

The filter cleaning system, defined as "differential pressure", uses a vacuum generated in the filter chamber to create a sudden jet of air in the cartridge.



SECONDARY HEPA FILTERS

In order to guarantee absolute filtration quality, the BOOST models are equipped with secondary HEPA filters positioned on the back of the machine.

- ▶ Compact
- ▶ Easy to Transport
- ▶ Safe
- ▶ Maneuverable

POWERVAK Boost 101 is a compact and vertical vacuum cleaner, HEPA certified, designed to meet the customers' demand for a competitive vacuum cleaner, ensuring good suction performance, and the best possible filtration.

The renewal of the design with the installation of the motor in the lower rear part has allowed the creation of a low, compact and highly manoeuvrable aspirator for easy transport. The center of gravity, which has moved lower, has also made the extractor much more stable.



Primary filter with HEPA + PTFE filter media, useful for ensuring a smooth surface and reducing the impact of dust ▶

HEPA D.O.P. secondary filter for absolute filtering efficiency ▶

1 By-pass motor 1100W ▶

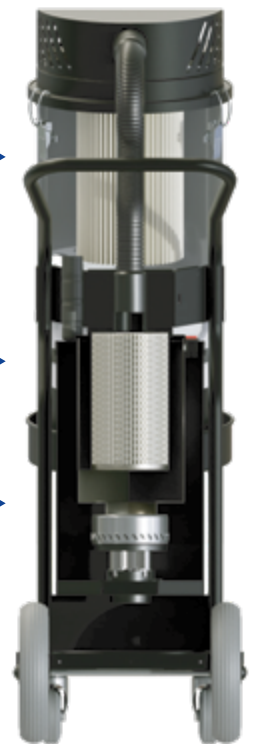

LONGOPAC® DUST COLLECTING SYSTEM

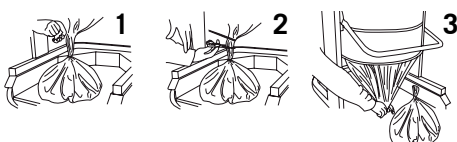

All models of the BOOST line are equipped with a Longopac continuous bag discharge system.

TECHNICAL DATA

Motorization	n°1 By-pass	Max Depression	230 mBar
Power	1100 W	Ø Nozzle	Tangential Ø 50 mm
Voltage	230 V	Body Diameter	Ø 330 mm
Frequency	50 / 60 Hz	Dimensions	41 x 73 x 129 cm
Amperage	4,8 A	Weight	39 Kg
Airflow	170 m³/h	Dust collecting	Longopac

FILTERING SYSTEM

Filter Type	Cartridge	Capacity	N°1 ULPA 15 - 9.500 cm²
Primary Filter-Surface	12.500 cm²	Filter Cleaning	Flow reversal
Filter Media	HEPA+PTFE	Price	€ 2.090,00

POWERVAK Boost 202

MANUAL CLEANING



FILTER SYSTEM
Cartridge filter with an innovative design, **without lower bottom** to ensure perfect dust discharge from the filter once cleaned.



DIFFERENTIAL PRESSURE CLEANING SYSTEM
The filter cleaning system, defined as "differential pressure", uses a vacuum generated in the filter chamber to create a sudden jet of air in the cartridge.



SECONDARY HEPA FILTERS
In order to guarantee absolute filtration quality, the BOOST models are equipped with secondary HEPA filters positioned on the back of the machine.

- ▶ Compact
- ▶ Easy to Transport
- ▶ Safe
- ▶ Maneuverable

POWERVAK Boost 202 is a compact and vertical vacuum cleaner, HEPA certified, designed to meet the customers' demand for a competitive vacuum cleaner, ensuring good suction performance, and the best possible filtration.

The renewal of the design with the installation of the motor in the lower rear part has allowed the creation of a low, compact and highly manoeuvrable aspirator for easy transport. The center of gravity, which has moved lower, has also made the extractor much more stable.



Primary filter with HEPA + PTFE filter media, useful for ensuring a smooth surface and reducing the impact of dust ▶

2 HEPA D.O.P. secondary filter for absolute filtering efficiency ▶

2 By-pass motor 2200W ▶



LONGOPAC® DUST COLLECTING SYSTEM

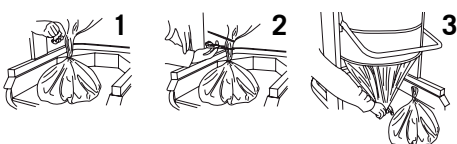

All models of the BOOST line are equipped with a Longopac continuous bag discharge system.

TECHNICAL DATA

Motorization	n°2 By-pass	Max Depression	230 mBar
Power	2200 W	Ø Nozzle	Tangential Ø 60 mm
Voltage	230 V	Body Diameter	Ø 330 mm
Frequency	50 / 60 Hz	Dimensions	48 x 73 x 138 cm
Amperage	9,6 A	Weight	49 Kg
Airflow	340 m³/h	Dust collecting	Longopac

FILTERING SYSTEM

Filter Type	Cartridge	Capacity	n°2 ULPA 15 - 19.000 cm²
Primary Filter-Surface	22.000 cm²	Filter Cleaning	Flow reversal
Filter Media	HEPA+2 PTFE	Price	€ 2.925,00

MANUAL CLEANING

POWERVAK Boost 303

**FILTER SYSTEM**

Cartridge filter with an innovative design, **without lower bottom** to ensure perfect dust discharge from the filter once cleaned.

**DIFFERENTIAL PRESSURE CLEANING SYSTEM**

The filter cleaning system, defined as "differential pressure", uses a vacuum generated in the filter chamber to create a sudden jet of air in the cartridge.

**SECONDARY HEPA FILTERS**

In order to guarantee absolute filtration quality, the BOOST models are equipped with secondary HEPA filters positioned on the back of the machine.

▶ Compact

▶ Easy to Transport

▶ Safe

▶ Maneuverable

POWERVAK Boost 303 is a compact and vertical vacuum cleaner, HEPA certified, designed to meet the customers' demand for a competitive vacuum cleaner, ensuring good suction performance, and the best possible filtration.

The renewal of the design with the installation of the motor in the lower rear part has allowed the creation of a low, compact and highly manoeuvrable aspirator for easy transport. The center of gravity, which has moved lower, has also made the extractor much more stable.



Primary filter with HEPA + PTFE filter media, useful for ensuring a smooth surface and reducing the impact of dust ▶

3 HEPA D.O.P. secondary filter for absolute filtering efficiency ▶

3 By-passmotor 3300W ▶



LONGOPAC® DUST COLLECTING SYSTEM

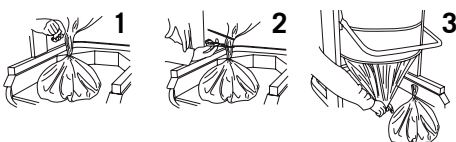

All models of the BOOST line are equipped with a Longopac continuous bag discharge system.

TECHNICAL DATA

Motorization	n°3 By-pass	Max Depression	230 mBar
Power	3300 W	Ø Nozzle	Tangential Ø 60 mm
Voltage	230 V	Body Diameter	Ø 400 mm
Frequency	50 / 60 Hz	Dimensions	48 x 91 x 138 cm
Amperage	14,4 A	Weight	65 Kg
Airflow	510 m³/h	Dust collecting	Longopac

FILTERING SYSTEM

Filter Type	Cartridge	Capacity	N°3 ULPA 15 - 25.500 cm²
Primary Filter-Surface	26.500 cm²	Filter Cleaning	Flow reversal
Filter Media	HEPA+3 PTFE	Price	€ 4.445,00

POWERVAK ASC

INDUSTRIAL VACUUMS WITH HEPA FILTERS AND ASC AUTOMATIC FILTERS SELF CLEANING

Industrial vacuum cleaners with ASC, equipped with an **automatic filter cleaning** are suitable for big quantity of concrete fine dust. Reliable and efficient, they are perfect for continuous applications without interruption even 24 hours on 24. The motor with side channel blowers provide excellent performance and can work continuously.

► NO-STOP ASPIRATION - Always clean filters for machines in production for no-stop applications

Thanks to this technology, the models equipped with the ASC cleaning system ensure constant suction performance by independently ensuring the cleaning of the filters without any intervention by the operator and without ever interrupting suction.

Highest standard with filters HEPA

The safety of a dusted work environment is guaranteed by the use of HEPA filters able to filter 99.995 of dust with 0.3 granulometry.

The filter surface is also covered with a PTFE membrane that makes the surface smoother and therefore easier to clean. In addition, the PTFE membrane makes the filters waterproof.

HEPA
filter



ASC 155 BAG

ASC 350 BAG

ASC 235 BAG



MADE in ITALY



POWERVAK ASC

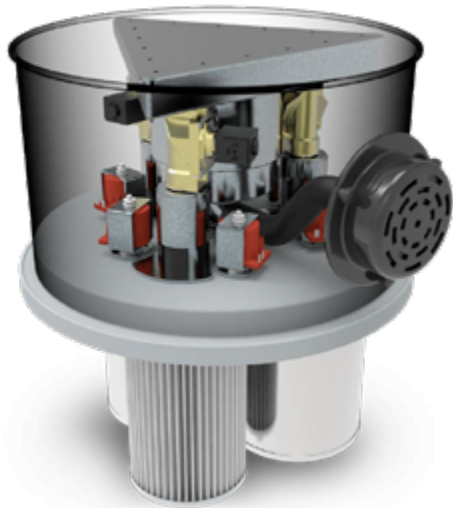

Endless suction filters kept constantly cleaned for non-stop production machinery

Industrial vacuum cleaners with ASC suitable for grinding machines and industrial concrete floor preparation, for sucking up large quantities of fine concrete dust, without interrupting the suction. The patented ASC system ensure a constant suction performance ensuring independently the cleaning of the filters without any user intervention and without interrupting the vacuum.

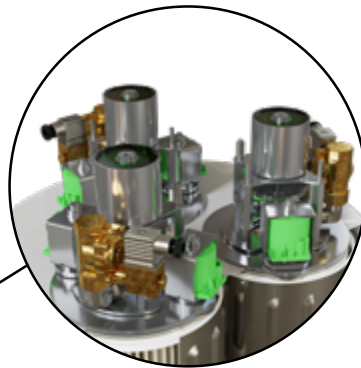
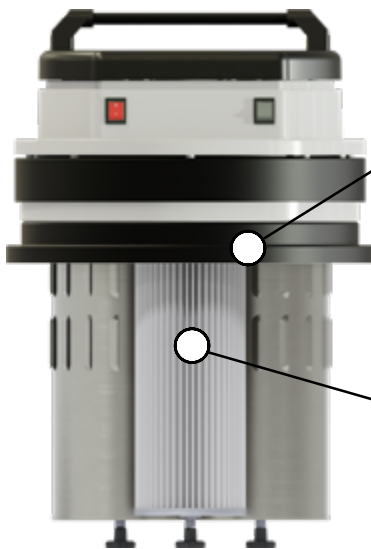

POWERVAK ASC: HOW IT WORKS?

The industrial vacuums ASC are multi-filter vacuum cleaners. All filters work together for 2 minutes at the end of which the cyclic cleaning take place by vibrating action; the system provides the closure suction on the filter to allow the fall of the accumulated dust and the vibration of the filter. During the cyclic cleaning, the other installed filters continue to aspirate. That allow to work without interruption.

HIGHEST STANDARD WITH FILTERS HEPA

The safety of a dusted work environment is guaranteed by the use of HEPA filters able to filter 99.995 of dust with 0.3 granulometry.

The filter surface is also covered with a PTFE membrane that makes the surface smoother and therefore easier to clean. In addition, the PTFE membrane makes the filters waterproof. The external part is produced using conductive material to allow the discharge of electrostatic currents during use.

PATENTED WATERTIGHT FILTER CLEANING SYSTEM

The filters are completely closed during cleaning, which greatly increases cleaning efficiency.

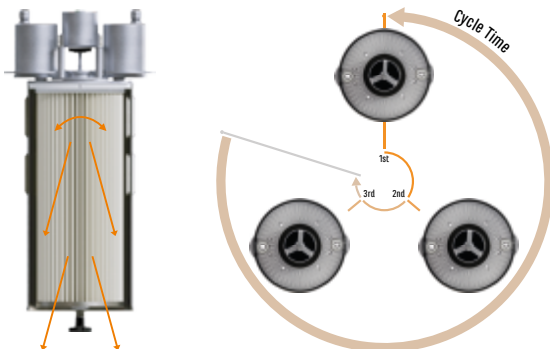

ASC CLEANING SYSTEM

The filter cleaning cycle consists of phases in which the suction of one element is interrupted at a time. The other filtering components remain active, guaranteeing the continuity of the suction action.

LONGOPAC® DUST COLLECTING SYSTEM

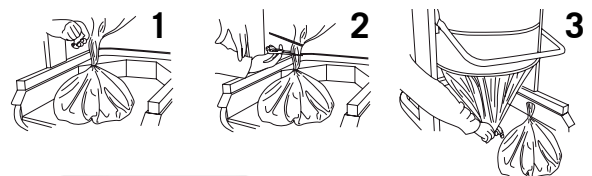

All BAGS models are equipped with a Longopac continuous bag system which allows the bagging of fine and dry dust, creating bags of variable size and weight, to be able to seal them and conveniently dispose them in absolute safety.

WHATEVER YOUR JOB DEMANDS... WE HAVE A SOLUTION FOR YOU



AUTO SELF-CLEANING

POWERVAK ASC 220



Tangential inlet for better dust separation from the filter

Bigger rear wheels

POWERVAK ASC 220 is the ideal partner for all professionals who require excellent suction performance and excellent filtering capabilities. A concentration of power and reliability packed into an extremely robust tool, with limited dimensions. Find its ideal application in construction employment, in bodywork or in any industry that need a practical use vacuum cleaner, good maneuverability for the suction of fine dust, whether it is connected to power tools, sanding or used as a simple tool.

Extremely compact vacuum cleaner, developed to meet the needs of the market by offering efficient suction of fine dust as well as being easy to manipulate or transportable in any location thanks to the larger posterior wheels and, at the same time, remaining a robust industrial vacuum cleaner.

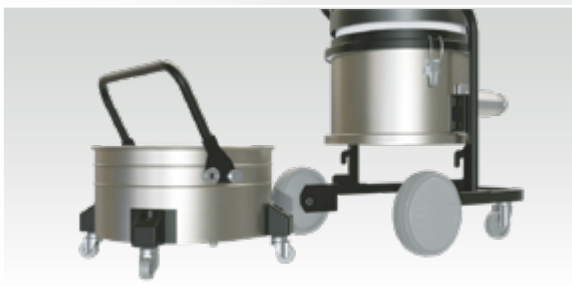
**TANK QUICK RELEASE FOR FAST DISPOSAL**

The release system for the container allows for effortless emptying of the cleaner thanks to the detachment of the vacuum head.

2 By-pass motor



Switch for forced filter cleaning



ASC Fully automatic filter cleaning
Constant and endless suction
2 HEPA Filters + PTFE Membrane

POWERVAK ASC 220 Tool
Plug socket + Remote Start
throughout power tools
Max 16A

**NO-STOP ASPIRATION**

Always clean filters for machines in production for no-stop applications. Thanks to this technology, the models equipped with the ASC cleaning system ensure constant suction performance by independently ensuring the cleaning of the filters without any intervention by the operator and without ever interrupting suction.

HIGHEST STANDARD with filters HEPA

The safety of a dusted work environment is guaranteed by the use of HEPA filters able to filter 99.995 of dust with 0.3 granulometry. The filter surface is also covered with a PTFE membrane that makes the surface smoother and therefore easier to clean. In addition, the PTFE membrane makes the filters waterproof.

TECHNICAL DATA

Motorization	n°2 By-pass	Max Depression	230 mBar
Power	2200 W	Ø Nozzle	Tangential Ø 60 mm
Voltage	230 V	Tank Diameter	Ø 400 mm
Frequency	50 / 60 Hz	Dimensions	54 x 58 x 85 cm
Amperage	9,6 A	Weight	36 Kg
Airflow	340 m³/h	Capacity	Tank 20 Lt

FILTERING SYSTEM

Filter Type	2 x Cartridge	Filter Cleaning	Automatic
Filter-Surface	5.200 cm²	Price ASC 220	€ 1.725,00
Filter Media	HEPA+PTFE	Price ASC 220 Tool	€ 1.875,00

POWERVAK ASC 235

AUTO SELF-CLEANING



Tangential inlet for better dust separation from the filter

Storage container



2 By-pass motor

Switch for forced filter cleaning

ASC Fully automatic filter cleaning
Constant and endless suction
2 HEPA Filters + PTFE Membrane

POWERVAK ASC 235 Tool
Plug socket + Remote Start
throughout power tools
Max 16A

POWERVAK ASC 235 increased evolution compared to the more moderate POWERVAK ASC 220 stands for more filtering capabilities and greater capacity. The reinforced trolley from the previous one allows its use in industrial environments with the most demanding applications, especially those regarding the coupling of machines that generate large amounts of dust.

Single-phase industrial vacuum cleaner with 2 collector motors, suitable for safe operation in any environment or application where there are large quantities of dust to be vacuumed thanks to the use of 2 H class filters in series and a fully automatic filter cleaning system.



TANK QUICK RELEASE FOR FAST DISPOSAL

The release system for the container allows for effortless emptying of the cleaner thanks to the detachment of the vacuum head.

NO-STOP ASPIRATION

Always clean filters for machines in production for no-stop applications. Thanks to this technology, the models equipped with the ASC cleaning system ensure constant suction performance by independently ensuring the cleaning of the filters without any intervention by the operator and without ever interrupting suction.

HIGHEST STANDARD with filters HEPA

The safety of a dusted work environment is guaranteed by the use of HEPA filters able to filter 99.995 of dust with 0.3 granulometry. The filter surface is also covered with a PTFE membrane that makes the surface smoother and therefore easier to clean. In addition, the PTFE membrane makes the filters waterproof.

TECHNICAL DATA			
Motorization	n°2 By-pass	Max Depression	230 mBar
Power	2200 W	Ø Nozzle	Tangential Ø 60 mm
Voltage	230 V	Tank Diameter	Ø 400 mm
Frequency	50 / 60 Hz	Dimensions	65 x 50 x 111 cm
Amperage	9,6 A	Weight	42 Kg
Airflow	340 m³/h	Capacity	Tank 35 Lt
FILTERING SYSTEM			
Filter Type	2 x Cartridge	Filter Cleaning	Automatic
Filter-Surface	8.000 cm²	Price ASC 235	€ 2.010,00
Filter Media	HEPA+PTFE	Price ASC 235 Tool	€ 2.160,00

AUTO SELF-CLEANING

POWERVAK ASC 235 BAG



Tangential inlet for better dust separation from the filter

Longopac® continuous bag collecting system 22 meters

Bigger rear wheels

Storage container

POWERVAK 235 BAG single-phase industrial vacuum cleaner with 2 collector motors, suitable for safe operation in any environment or application where there are large quantities of dust to be vacuumed thanks to the use of 2 H class filters in series and a fully automatic filter cleaning system, ensuring effective performance and prolonged in time.

Equipped with LONGOPAC® collection system: the disposal of the vacuumed material is facilitated by the use of collection bags that, once sealed, prevent contamination of the work environment and provide additional safety for the health of the operator.

LONGOPAC® DUST COLLECTING SYSTEM

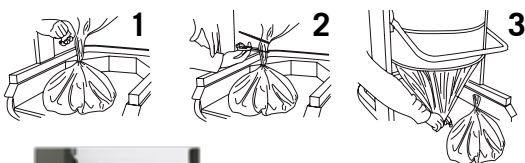

All BAGS models are equipped with a Longopac continuous bag system which allows the bagging of fine and dry dust, creating bags of variable size and weight, to be able to seal them and conveniently dispose them in absolute safety.

2 By-pass motor

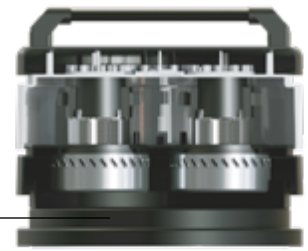

Switch for forced filter cleaning



ASC Fully automatic filter cleaning
Constant and endless suction
2 HEPA Filters + PTFE Membrane

POWERVAK ASC 235B Tool
Plug socket + Remote Start
through power tools
Max 16A



NO-STOP ASPIRATION

Always clean filters for machines in production for no-stop applications. Thanks to this technology, the models equipped with the ASC cleaning system ensure constant suction performance by independently ensuring the cleaning of the filters without any intervention by the operator and without ever interrupting suction.

HIGHEST STANDARD with filters HEPA

The safety of a dusted work environment is guaranteed by the use of HEPA filters able to filter 99.995 of dust with 0.3 granulometry.

TECHNICAL DATA

Motorization	n°2 By-pass	Max Depression	230 mBar
Power	2400 W	Ø Nozzle	Tangential Ø 60 mm
Voltage	230 V	Tank Diameter	Ø 370 mm
Frequency	50 / 60 Hz	Dimensions	70 x 54 x 122 cm
Amperage	9,6 A	Weight	61 Kg
Airflow	340 m³/h	Capacity	Longopac

FILTERING SYSTEM

Filter Type	2 x Cartridge	Filter Cleaning	Automatic
Filter-Surface	8.000 cm²	Price ASC 235 BAG	€ 2.610,00
Filter Media	HEPA+PTFE	Price ASC 235B Tool	€ 2.760,00

LONGOPAC BOX with 4 cartridge of 22meters

€ 195,00

POWERVAK ASC 350

AUTO SELF-CLEANING



3 By-pass motor



Switch for forced filter cleaning



ASC Fully automatic filter cleaning
Constant and endless suction
3 HEPA Filters + PTFE Membrane

POWERVAK ASC 350 model is a single-phase industrial vacuum cleaner with 3 collector motors. Model most appreciated by those who use it in daily work, especially in the field of surface treatment. The most efficient single-phase vacuum cleaner in the world for the suction of fine dust, deriving from machines in production such as sanders. Its field of application is not limited to construction, but ranges in any environment or application where there are large quantities of dust to be vacuumed thanks to the use of 3 H class filters in series and a fully automatic filter cleaning system.

NO-STOP ASPIRATION

Always clean filters for machines in production for no-stop applications. Thanks to this technology, the models equipped with the ASC cleaning system ensure constant suction performance by independently ensuring the cleaning of the filters without any intervention by the operator and without ever interrupting suction.

HIGHEST STANDARD with filters HEPA

The safety of a dusted work environment is guaranteed by the use of HEPA filters able to filter 99.995 of dust with 0.3 granulometry.



TANK QUICK RELEASE FOR FAST DISPOSAL

The release system for the container allows for effortless emptying of the cleaner thanks to the detachment of the vacuum head.

TECHNICAL DATA

Motorization	n°3 By-pass	Max Depression	510 mBar
Power	3300 W	Ø Nozzle	Tangential Ø 60 mm
Voltage	230 V	Tank Diameter	Ø 460 mm
Frequency	50 / 60 Hz	Dimensions	80 x 60 x 118 cm
Amperage	14,4 A	Weight	65 Kg
Airflow	340 m³/h	Capacity	Tank 50 Lt

FILTERING SYSTEM

Filter Type	3 x Cartridge	Filter Cleaning	Automatic
Filter-Surface	20.500 cm²		
Filter Media	HEPA+PTFE	Price ASC 350	€ 2.660,00

AUTO SELF-CLEANING

POWERVAK ASC 350 BAG



Tangential inlet for better dust separation from the filter

Longopac® continuous bag collecting system 22 meters

Storage container

Bigger rear wheels

POWERVAK ASC 350 BAG model is a single-phase industrial vacuum cleaner with 3 collector motors, suitable for safe operation in any environment or application where there are large quantities of dust to be vacuumed thanks to the use of 3 H class filters in series and a fully automatic filter cleaning system.

Equipped with LONGOPAC® collection system: the disposal of the vacuumed material is facilitated by the use of collection bags that, once sealed, prevent contamination of the work environment and provide additional safety for the health of the operator.

LONGOPAC® DUST COLLECTING SYSTEM

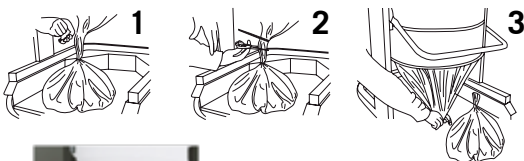

All BAGS models are equipped with a Longopac continuous bag system which allows the bagging of fine and dry dust, creating bags of variable size and weight, to be able to seal them and conveniently dispose them in absolute safety.

3 By-pass motor

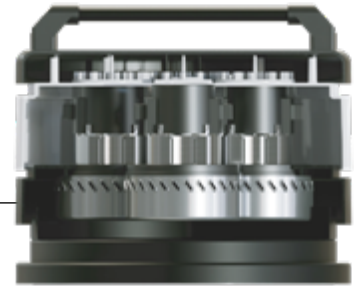

Switch for forced filter cleaning

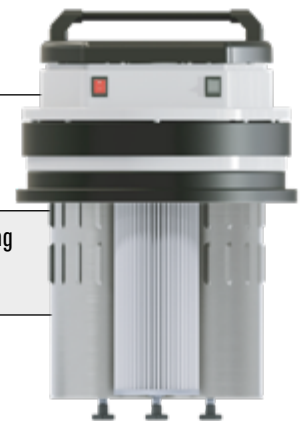

ASC Fully automatic filter cleaning
Constant and endless suction
3 HEPA Filters + PTFE Membrane

NO-STOP ASPIRATION

Always clean filters for machines in production for no-stop applications. Thanks to this technology, the models equipped with the ASC cleaning system ensure constant suction performance by independently ensuring the cleaning of the filters without any intervention by the operator and without ever interrupting suction.

HIGHEST STANDARD with filters HEPA

The safety of a dusted work environment is guaranteed by the use of HEPA filters able to filter 99.995 of dust with 0.3 granulometry.

TECHNICAL DATA

Motorization	n°3 By-pass	Max Depression	230 mBar
Power	3600 W	Ø Nozzle	Tangential Ø 60 mm
Voltage	230 V	Tank Diameter	Ø 460 mm
Frequency	50 / 60 Hz	Dimensions	80 x 60 x 142 cm
Amperage	14,4 A	Weight	74 Kg
Airflow	510 m³/h	Capacity	Longopac

FILTERING SYSTEM

Filter Type	3 x Cartridge	Filter Cleaning	Automatic
Filter-Surface	20.500 cm²		
Filter Media	HEPA + PTFE	Price ASC 350 BAG	€ 3.540,00

LONGOPAC BOX with 4 cartridge of 22meters

€ 195,00

POWERSAK ASC ST

AUTO SELF-CLEANING



Tangential inlet for better dust separation from the filter

Storage container

Bigger rear wheels

Filter protection for improved cyclonic efficiency and protection from abrasive materials

Fully automatic filter cleaning as standard

Suction always present and efficient

3 HEPA cartridge filters + PTFE membrane for standard models

3 conductive HEPA cartridge filters for ATEX models

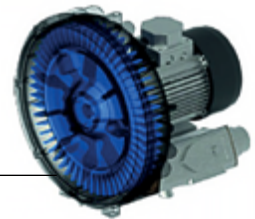
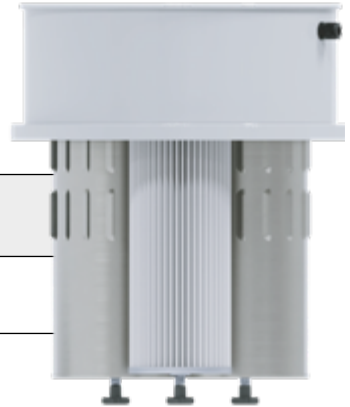

Side channel turbine
2.2 Kw / 3Kw

The **POWERSAK ASC ST 2.2 / ST 3** models are among the only industrial vacuum cleaners on the market with side channel turbine single-stage single-phase or three-phase to boast automatic cleaning system of the filters. These vacuum cleaners have all the intrinsic benefits of the vertical design, such as reduced mobility for space in confined areas also offer the highest filtration efficiency thanks to the automatic cleaning system of filters ASC with standard HEPA filtration and absolute reliability in continuous use. Extremely sturdy, silent, powerful and reliable and suitable for continuous use 24 hours a day.



TANK QUICK RELEASE FOR FAST DISPOSAL

The release system for the container allows for effortless emptying of the cleaner thanks to the detachment of the vacuum head.

TECHNICAL DATA ST 2.2			
Motorization	Turbine	Max Depression	200 mBar
Power	2.2 Kw	Ø Nozzle	Tangential Ø 60 mm
Voltage	230 V	Tank Diameter	Ø 460 mm
Frequency	50 Hz	Dimensions	85 x 65 x 199 cm
Amperage	16 A	Weight	92 Kg
Airflow	320 m³/h	Capacity	Tank 100 Lt
FILTERING SYSTEM			
Filter Type	3 x Cartridge	Filter Cleaning	Automatic
Filter-Surface	21.000 cm²		
Filter Media	HEPA + PTFE	Price ASC ST2.2	€ 5.230,00

TECHNICAL DATA ST 3			
Motorization	Turbine	Max Depression	250 mBar
Power	3 Kw	Ø Nozzle	Tangential Ø 60 mm
Voltage	400 V	Tank Diameter	Ø 460 mm
Frequency	50 Hz	Dimensions	85 x 65 x 199 cm
Amperage	16 A	Weight	92 Kg
Airflow	320 m³/h	Capacity	Tank 100 Lt
FILTERING SYSTEM			
Filter Type	3 x Cartridge	Filter Cleaning	Automatic
Filter-Surface	21.000 cm²		
Filter Media	HEPA + PTFE	Price ASC ST3	€ 5.090,00

AUTO SELF-CLEANING

POWERVAK ASC ST BAG



Tangential inlet for better dust separation from the filter

Longopac® continuous bag collecting system 22 meters

Storage container

Bigger rear wheels

Side channel turbine
2.2 Kw / 3Kw

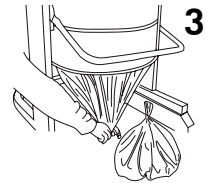
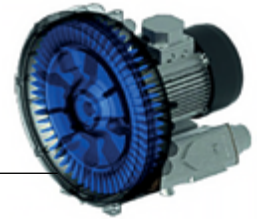

The **POWERVAK ASC ST 2.2 BAG / ST 3 BAG** models are among the only industrial vacuum cleaners on the market with side channel turbine 2.2 Kw or 3 Kw to boast automatic cleaning system of the filters.

NO-STOP ASPIRATION

Always clean filters for machines in production for no-stop applications. Thanks to this technology, the models equipped with the ASC cleaning system ensure constant suction performance by independently ensuring the cleaning of the filters without any intervention by the operator and without ever interrupting suction.

LONGOPAC® DUST COLLECTING SYSTEM

All BAGS models are equipped with a Longopac continuous bag system which allows the bagging of fine and dry dust, creating bags of variable size and weight, to be able to seal them and conveniently dispose them in absolute safety.

HIGHEST STANDARD with filters HEPA

The safety of a dusted work environment is guaranteed by the use of HEPA filters able to filter 99.995 of dust with 0.3 granulometry.

LONGOPAC BOX with 4 cartridge of 22meters

€ 195,00

TECHNICAL DATA ST 2.2 BAG

Motorization	Turbine	Max Depression	200 mBar
Power	2.2 Kw	Ø Nozzle	Tangential Ø 60 mm
Voltage	230 V	Tank Diameter	Ø 460 mm
Frequency	50 Hz	Dimensions	85 x 65 x 199 cm
Amperage	16 A	Weight	92 Kg
Airflow	320 m³/h	Capacity	Longopac

FILTERING SYSTEM

Filter Type	3 x Cartridge	Filter Cleaning	Automatic
Filter-Surface	21.000 cm²		
Filter Media	HEPA + PTFE	Price ASC ST2.2 B	€ 5.865,00

TECHNICAL DATA ST 3 BAG

Motorization	Turbine	Max Depression	250 mBar
Power	3 Kw	Ø Nozzle	Tangential Ø 60 mm
Voltage	400 V	Tank Diameter	Ø 460 mm
Frequency	50 Hz	Dimensions	85 x 65 x 199 cm
Amperage	16 A	Weight	92 Kg
Airflow	320 m³/h	Capacity	Longopac

FILTERING SYSTEM

Filter Type	3 x Cartridge	Filter Cleaning	Automatic
Filter-Surface	21.000 cm²		
Filter Media	HEPA + PTFE	Price ASC ST3 BAG	€ 5.726,00

POWERVAK ASC 155

AUTO SELF-CLEANING



Tangential inlet for better dust separation from the filter

Suction always present and efficient

ASC Fully automatic filter cleaning
Constant and endless suction
3 HEPA Filters + PTFE Membrane
Filter Surface 30.000 cm²

Filter guard for improved cyclonic efficiency and protection from abrasive materials

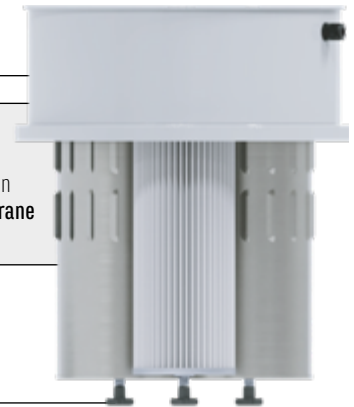

Double stage
Side channel turbine
3 Kw / 5.5 Kw

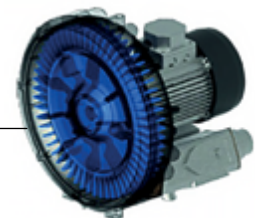

POWERVAK ASC 155 models are among the most popular three-phase models in our range as they ensure maximum reliability and a more efficient filtering capacity thanks to the ASC automatic cleaning system of filters that never stop the intake and make it the ideal vacuum cleaner to respond to requests for continuous and prolonged aspirations over time, particularly suitable in cases of production machinery connections.



NO-STOP ASPIRATION

Always clean filters for machines in production for no-stop applications. Thanks to this technology, the models equipped with the ASC cleaning system ensure constant suction performance by independently ensuring the cleaning of the filters without any intervention by the operator and without ever interrupting suction.

HIGHEST STANDARD with filters HEPA

The safety of a dusted work environment is guaranteed by the use of HEPA filters able to filter 99.995 of dust with 0.3 granulometry. The filter surface is also covered with a PTFE membrane that makes the surface smoother and therefore easier to clean. In addition, the PTFE membrane makes the filters waterproof.

TANK QUICK RELEASE FOR FAST DISPOSAL

The release system for the container allows for effortless emptying of the cleaner thanks to the detachment of the vacuum head.

	Motor	Power	Voltage/Freq	Amp	Filter Clean	Filter	Airflow	Dep. Max	Capacity	Weight	Dimension (cm)	PRICE
ASC 130	Turbine	3 Kw	400V / 50 Hz	6,7 A	Automatic	HEPA+PTFE	320 m ³ /h	320 mBar	100 Lt	150 Kg	110 x 60 x 168	€ 6.485,00
ASC 155 P	Turbine	5.5Kw	400V / 50 Hz	10,4 A	Automatic	HEPA+PTFE	520 m ³ /h	320 mBar	100 Lt	163 Kg	110 x 60 x 168	€ 7.125,00
ASC 155 S	Turbine	5.5Kw	400V / 50 Hz	10,4 A	Automatic	HEPA+PTFE	320 m ³ /h	530 mBar	100 Lt	163 Kg	110 x 60 x 168	€ 7.125,00

Voltage available: 220 V - 60 Hz / 480 V - 60 Hz / 575 V - 60 Hz
Versions with filter cleaning by vibrations and blowing motor on-board

AUTO SELF-CLEANING

POWERVAK ASC 155 BAG



Tangential inlet for better dust separation from the filter

Longopac® continuous bag collecting system
22 meters

Suction always present and efficient

ASC Fully automatic filter cleaning
Constant and endless suction
3 HEPA Filters + PTFE Membrane
Filter Surface 30.000 cm²

Filter guard for improved cyclonic efficiency and protection from abrasive materials

Double stage
Side channel turbine
3 Kw / 5.5 Kw

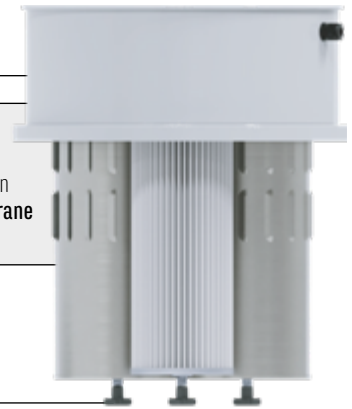

POWERVAK ASC 155 BAG models are among the most popular three-phase models in our range as they ensure maximum reliability and a more efficient filtering capacity thanks to the ASC automatic cleaning system of filters that never stop the intake and make it the ideal vacuum cleaner to respond to requests for continuous and prolonged aspirations over time, particularly suitable in cases of production machinery connections.

Equipped with **LONGOPAC®** collection system: the disposal of the vacuumed material is facilitated by the use of collection bags that, once sealed, prevent contamination of the work environment and provide additional safety for the health of the operator.

HIGHEST STANDARD with filters HEPA

The safety of a dusted work environment is guaranteed by the use of HEPA filters able to filter 99.995 of dust with 0.3 granulometry.

NO-STOP ASPIRATION

Always clean filters for machines in production for no-stop applications. Thanks to this technology, the models equipped with the ASC cleaning system ensure constant suction performance by independently ensuring the cleaning of the filters without any intervention by the operator and without ever interrupting suction.

LONGOPAC® DUST COLLECTING SYSTEM

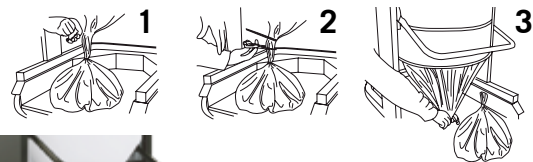

All BAGS models are equipped with a Longopac continuous bag system which allows the bagging of fine and dry dust, creating bags of variable size and weight, to be able to seal them and conveniently dispose them in absolute safety.

	Motor	Power	Voltage/Freq	Amp	Filter Clean	Filter	Airflow	Dep. Max	Capacity	Weight	Dimension (cm)	PRICE
ASC 130 BAG	Turbine	3 Kw	400V / 50 Hz	6,7 A	Automatic	HEPA+PTFE	320 m ³ /h	320 mBar	Longopac	150 Kg	110 x 60 x 168	€ 7.125,00
ASC 155 P BAG	Turbine	5.5Kw	400V / 50 Hz	10,4 A	Automatic	HEPA+PTFE	520 m ³ /h	320 mBar	Longopac	163 Kg	110 x 60 x 168	€ 7.750,00
ASC 155 S BAG	Turbine	5.5Kw	400V / 50 Hz	10,4 A	Automatic	HEPA+PTFE	320 m ³ /h	530 mBar	Longopac	163 Kg	110 x 60 x 168	€ 7.750,00

Voltage available: 220 V - 60 Hz / 480 V - 60 Hz / 575 V - 60 Hz
Versions with filter cleaning by vibrations and blowing motor on-board

LONGOPAC BOX with 4 cartridge of 22meters

€ 195,00

POWERVAK ASC 255

AUTO SELF-CLEANING



Tangential inlet for better dust separation from the filter

160 Liters Capacity Tank

Suction always present and efficient

ASC Fully automatic filter cleaning
Constant and endless suction
5 HEPA Filters
+ PTFE Membrane

Filter guard for improved cyclonic efficiency and protection from abrasive materials

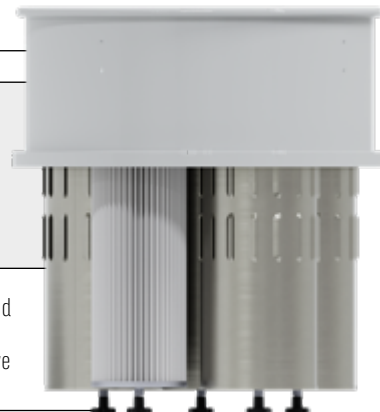

Two Double stage Side channel turbine
2 x 5.5KW / 11 Kw

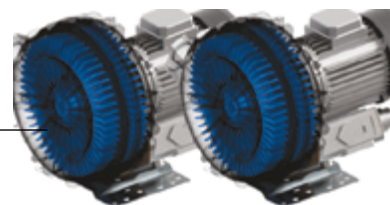

POWERVAK ASC 255 models are extremely powerful industrial vacuum cleaners with double side channel turbine for a total of 11 kW. The more efficient filtering capacity is guaranteed by the automatic cleaning system of filters ASC that never stop the suction and make it the ideal vacuum cleaner to meet the demands of continuous and prolonged aspirations over time, particularly suitable in cases of links to machinery production or construction of centralized systems.

Voltage available: 220 V - 60 Hz / 480 V - 60 Hz / 575 V - 60 Hz
Versions with filter cleaning by vibrations and blowing motor on-board



TANK QUICK RELEASE FOR FAST DISPOSAL

The release system for the container allows for effortless emptying of the cleaner thanks to the detachment of the vacuum head.

TECHNICAL DATA ASC 255 P

Motorization	2 x Turbine	Max Depression	320 mBar
Power	11 Kw	Ø Nozzle	Tangential Ø 90 mm
Voltage	400 V	Tank Diameter	Ø 560 mm
Frequency	50 Hz	Dimensions	155 x 77 x 185 cm
Amperage	21 A	Weight	350 Kg
Airflow	1040 m³/h	Capacity	Tank 160 Lt

FILTERING SYSTEM

Filter Type	5 x Cartridge	Filter Cleaning	Automatic
Filter-Surface	50.000 cm²		
Filter Media	HEPA + PTFE	Price ASC 255 P	€ 14.060,00

TECHNICAL ASC 255 S

Motorization	2 x Turbine	Max Depression	530 mBar
Power	100 Kw	Ø Nozzle	Tangential Ø 90 mm
Voltage	400 V	Tank Diameter	Ø 560 mm
Frequency	50 Hz	Dimensions	155 x 77 x 185 cm
Amperage	21 A	Weight	350 Kg
Airflow	640 m³/h	Capacity	Tank 160 Lt

FILTERING SYSTEM

Filter Type	5 x Cartridge	Filter Cleaning	Automatic
Filter-Surface	50.000 cm²		
Filter Media	HEPA + PTFE	Price ASC 255 S	€ 14.060,00

AUTO SELF-CLEANING

POWERVAK ASC 255 BAG



Tangential inlet for better dust separation from the filter

Longopac® continuous bag collecting system
22 meters

Suction always present and efficient

ASC Fully automatic filter cleaning
Constant and endless suction
5 HEPA Filters
+ PTFE Membrane

Filter guard for improved cyclonic efficiency and protection from abrasive materials

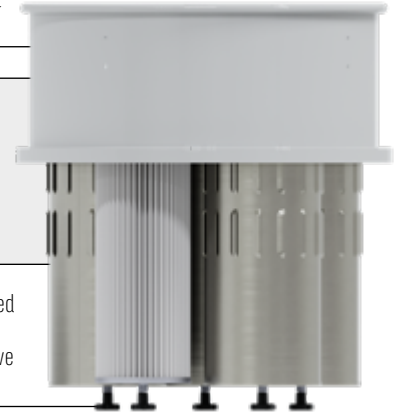

Two Double stage Side channel turbine
2 x 5.5KW / 11 Kw

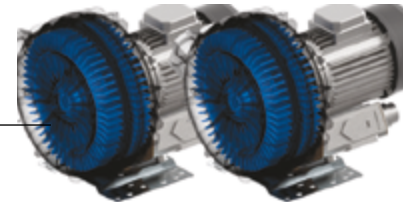

POWERVAK ASC 255 BAG models are extremely powerful industrial vacuum cleaners with double side channel turbine for a total of 11 kW. The more efficient filtering capacity is guaranteed by the automatic cleaning system of filters ASC that never stop the suction and make it the ideal vacuum cleaner to meet the demands of continuous and prolonged aspirations over time, particularly suitable in cases of links to machinery production or construction of centralized systems.

Equipped with **LONGOPAC®** collection system.

Voltage available: 220 V - 60 Hz / 480 V - 60 Hz / 575 V - 60 Hz
Versions with filter cleaning by vibrations and blowing motor on-board

LONGOPAC® DUST COLLECTING SYSTEM



All BAGS models are equipped with a Longopac continuous bag system which allows the bagging of fine and dry dust, creating bags of variable size and weight, to be able to seal them and conveniently dispose them in absolute safety.

LONGOPAC BOX with 4 cartridge of 22meters

€ 195,00

TECHNICAL DATA ASC 255 P BAG

Motorization	2 x Turbine	Max Depression	320 mBar
Power	11 Kw	Ø Nozzle	Tangential Ø 90 mm
Voltage	400 V	Tank Diameter	Ø 560 mm
Frequency	50 Hz	Dimensions	155 x 77 x 185 cm
Amperage	21 A	Weight	350 Kg
Airflow	1040 m³/h	Capacity	Longopac

FILTERING SYSTEM

Filter Type	5 x Cartridge	Filter Cleaning	Automatic
Filter-Surface	50.000 cm²		
Filter Media	HEPA + PTFE	Price 255 P BAG	€ 14.850,00

TECHNICAL DATA ASC 255 S BAG

Motorization	2 x Turbine	Max Depression	530 mBar
Power	11 Kw	Ø Nozzle	Tangential Ø 90 mm
Voltage	400 V	Tank Diameter	Ø 560 mm
Frequency	50 Hz	Dimensions	155 x 77 x 185 cm
Amperage	21 A	Weight	350 Kg
Airflow	640 m³/h	Capacity	Longopac

FILTERING SYSTEM

Filter Type	5 x Cartridge	Filter Cleaning	Automatic
Filter-Surface	50.000 cm²		
Filter Media	HEPA + PTFE	Price 255 S BAG	€ 14.850,00

POWERVAK Base

INDUSTRIAL VACUUMS GENERIC ALL-PURPOSE AND MODULAR

The range of industrial vacuum cleaners of the Base line is built with the classical and conventional filter systems known on the market; polyester fabric filters / nonwoven defined in pockets or stellar. Base line is suitable for multiple generic applications, but at the same time has the disadvantage of having little specific machines, especially in the case of intake of complex powders such as fine powders.

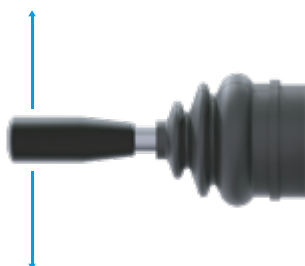

Manual shaking filter cleaning system



Pocket filter available in different size and materials



Secondary HEPA filter optional

► SUCTION OF DUST AND LIQUIDS (MODEL W)

Thanks to the deflector it directs the liquid flow downwards avoiding wetting the filter. To have a multipurpose vacuum cleaner, that is, suitable for the aspiration of any kind of material, dry or liquid, the choice of the type of nozzle prefers the central type inlet. This thanks to the deflector directs the flow of liquid downwards, avoiding wetting the filter. As for the suction of dust, it proves less effective than the tangential inlet as the deflector significantly slows down the flow of dust, which is more easily attracted to the filter.

A Wet & Dry (WD) multipurpose vacuum cleaner can have its inlet mounted centrally or laterally. A central inlet is preferable in case of liquids, as the deflector directs liquid downwards hence avoiding wetting the filter. A lateral inlet is preferable in case of dry materials as it helps with flowing of the material thanks to a better cyclonic effect. With Klinsystem you can choose both.

► ONLY DUST SUCTION (MODEL B)

The speed of the air and the entry into the container drum is higher than conventional central unions, favoring the cyclonic effect. The best configuration for dust extraction is the installation of the tangential type nozzle, as the speed of the air and the entry into the container drum is higher than conventional central nozzles favoring the cyclonic effect, therefore greater separation of the dust from the filter.

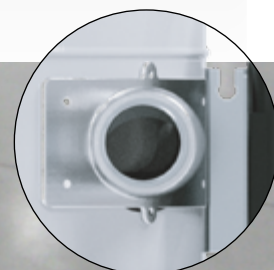

MADE in ITALY

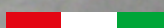

MANUAL CLEANING

POWERVAK Base WM 250



Manual filter
Cleaning device

Central inlet for
simultaneous suction
of dust, solids and liquids

Bigger rear
wheels

POWERVAK BASE WM 250 is the most classic and common single-phase industrial vacuum cleaner. 2 by-pass motors, 50 liters capacity, steel drums and conventional filtration in pockets or star filter. This model responds to multiple non-specific applications in the industrial field.



TANK QUICK RELEASE FOR FAST DISPOSAL

The release system for the container allows for effortless emptying of the cleaner thanks to the detachment of the vacuum head.

2 By-pass motors



Filtration Class L / M
13.000 cm²



OPTIONAL
secondary HEPA filter
€ 175,00



FILTERING SYSTEM

This series of BASE industrial vacuum cleaners refers to the more classic and simple filtration system normally used by most common industrial vacuum cleaners with filters made of polyester fabric / non-woven fabric with pockets or star shaped filters offering standard filtration of 3 μ particles that can be increased by using optional filters with PTFE membrane for 1 μ particles.

FILTERING SYSTEM WM250 L

Filter Type	Stellar polyester
Filter-Surface	13.000 cm ²
Filter Media	L
Filter Cleaning	Manual shaking

FILTERING SYSTEM WM250 M

Filter Type	Stellar polyester
Filter-Surface	13.000 cm ²
Filter Media	M
Filter Cleaning	Manual shaking

	Motor	Power	Voltage/Freq	Amp	Airflow	Dep. Max	Capacity	Weight	Dimension (cm)	Ø Nozzle	PRICE
WM 250 L	2 By-pass	2200W	230V/50-60Hz	9,6 A	340 m ³ /h	230 mBar	50 Lt	36 Kg	54 x 58 x 135	Central Ø 70 mm	€ 1.365,00
WM 250 M	2 By-pass	2200W	230V/50-60Hz	9,6 A	340 m ³ /h	230 mBar	50 Lt	36 Kg	54 x 58 x 135	Central Ø 70 mm	€ 1.455,00
WM 250 L Tool	2 By-pass	2200W	230V/50-60Hz	9,6 A	340 m ³ /h	230 mBar	50 Lt	36 Kg	54 x 58 x 135	Central Ø 70 mm	€ 1.515,00
WM 250 M Tool	2 By-pass	2200W	230V/50-60Hz	9,6 A	340 m ³ /h	230 mBar	50 Lt	36 Kg	54 x 58 x 135	Central Ø 70 mm	€ 1.605,00

POWERVAK Base BM 375

MANUAL CLEANING



Manual filter Cleaning device

Tangential inlet for better dust separation from the filter

Storage Container

POWERVAK BASE BM 375 is the most classic and common single-phase industrial vacuum cleaner. 3 by-pass motors and conventional filtration in pockets or star filter. Its maneuverability, combined with the compact design, allows it to be easily moved, even in the most confined spaces, facilitating routine cleaning of your machinery. Ideal for several applications not specific in the industrial field and in cases where there are no problems regarding large amounts of dust, especially the grainy one.



TANK QUICK RELEASE FOR FAST DISPOSAL

The release system for the container allows for effortless emptying of the cleaner thanks to the detachment of the vacuum head.

3 By-pass motors



Filtration Class L / M
20.000 / 30.000 cm²



OPTIONAL
secondary HEPA filter
€ 220,00



Available also model **POWERVAK BASE 375 WM** for simultaneous suction of dust, solids and liquids with central inlet. The deflector directs liquid downwards hence avoiding wetting the filter.

TECHNICAL DATA BM 375 L

Motorization	n°3 By-pass	Max Depression	230 mBar
Power	3300 W	Ø Nozzle	Tangential Ø 60 mm
Voltage	230 V	Tank Diameter	Ø 460 mm
Frequency	50 / 60 Hz	Dimensions	80 x 60 x 152 cm
Amperage	14,4 A	Weight	62 Kg
Airflow	510 m ³ /h	Capacity	Tank 75 Lt

FILTERING SYSTEM

Filter Type	Stellar polyester	Filter Cleaning	Manual Shaking
Filter-Surface	20.000 cm ²		
Filter Media	L	Price BM 375 L	€ 1.955,00

FILTRATION OPTIONS	Filtering Surface	Filtration	PRICE	FILTRATION OPTIONS	Filtering Surface	Filtration	PRICE
M Class Filter	20.000 cm ²	M	€ 112,00	Nomex filter High Temperature 200/220 C°	20.000 cm ²	M	€ 182,00
M Class Filter + Antistatic	20.000 cm ²	M	€ 180,00	L Class Filter	30.000 cm ²	L	€ 95,00
M Class Filter + PTFE	20.000 cm ²	M	€ 231,00	M Class Filter	30.000 cm ²	M	€ 215,00

MANUAL CLEANING

POWERVAK Base BM 3100



3 By-pass motors



Filtration Class L / M
20.000 / 30.000 cm²



OPTIONAL
secondary HEPA filter
€ 220,00



POWERVAK BASE BM 3100 is a BASE BM 375 direct derivation vacuum cleaner, strengthened with a new trolley and with features of great versatility and ease of use.

Available also model **POWERVAK BASE WM 3100** for simultaneous suction of dust, solids and liquids with central inlet. The deflector directs liquid downwards hence avoiding wetting the filter.



TANK QUICK RELEASE FOR FAST DISPOSAL

LONGOPAC® DUST COLLECTING SYSTEM

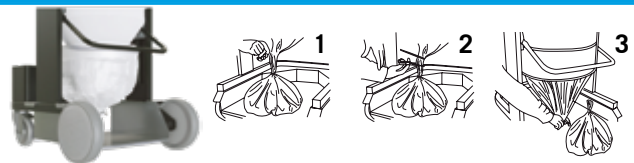

POWERVAK BASE BT 3100 BAG models are equipped with a Longopac continuous bag system which allows the bagging of fine and dry dust, creating bags of variable size and weight, to be able to seal them and conveniently dispose them in absolute safety.

LONGOPAC BOX with 4 cartridge of 22meters

€ 195,00

FILTERING SYSTEM

Filter Type	Stellar polyester	Filter Media	L
Filter-Surface	20.000 cm ²	Filter Cleaning	Manual shaking

	Motor	Power	Voltage/Freq	Amp	Airflow	Dep. Max	Capacity	Weight	Dimension (cm)	Ø Nozzle	PRICE
BM 3100 L	3 By-pass	3300W	230V/50-60Hz	14,4 A	510 m ³ /h	230 mBar	100 Lt	80 Kg	54 x 58 x 135	Tangential Ø 60 mm	€ 2.215,00
BM 3100 L BAG	3 By-pass	3300W	230V/50-60Hz	14,4 A	510 m ³ /h	230 mBar	Longopac	80 Kg	54 x 58 x 135	Tangential Ø 60 mm	€ 2.850,00

FILTRATION OPTIONS	Filtering Surface	Filtration	PRICE	FILTRATION OPTIONS	Filtering Surface	Filtration	PRICE
M Class Filter	20.000 cm ³	M	€ 112,00	Nomex filter High Temperature 200/220 C°	20.000 cm ³	M	€ 182,00
M Class Filter + Antistatic	20.000 cm ³	M	€ 180,00	L Class Filter	30.000 cm ³	L	€ 95,00
M Class Filter + PTFE	20.000 cm ³	M	€ 231,00	M Class Filter	30.000 cm ³	M	€ 215,00

POWERVAK Base BT 751

MANUAL CLEANING

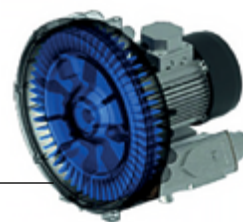

Side channel turbine
2.2 Kw / 3Kw



Filtration Class L / M
22.000 / 30.000 cm²



OPTIONAL
secondary HEPA filter
€ 220,00

POWERVAK BASE BT 751 models are the most popular turbine models as they enjoy excellent reliability thanks to the side channel turbine and are multipurpose for suction of any kind of debris but not recommended for fine dust. Their simplicity and veracity make them among the most popular models on the market.

TECHNICAL BT 751 L			
Motorization	Turbine	Max Depression	200 mBar
Power	2.2 Kw	Ø Nozzle	Tangential Ø 60 mm
Voltage	230 V	Tank Diameter	Ø 460 mm
Frequency	50 Hz	Dimensions	80 x 63 x 165 cm
Amperage	16 A	Weight	100 Kg
Airflow	320 m ³ /h	Capacity	Tank 75 Lt
FILTERING SYSTEM			
Filter Type	Stellar polyester	Filter Cleaning	Manual Shaking
Filter-Surface	22.000 cm ²		
Filter Media	L	Price BT 751 L	€ 2.785,00

TECHNICAL DATA BT 753 L			
Motorization	Turbine	Max Depression	250 mBar
Power	3 Kw	Ø Nozzle	Tangential Ø 60 mm
Voltage	400 V	Tank Diameter	Ø 460 mm
Frequency	50 / 60 Hz	Dimensions	80 x 63 x 165 cm
Amperage	6,7 A	Weight	100 Kg
Airflow	320 m ³ /h	Capacity	Tank 75 Lt
FILTERING SYSTEM			
Filter Type	Stellar polyester	Filter Cleaning	Manual Shaking
Filter-Surface	22.000 cm ²		
Filter Media	L	Price BT 753 L	€ 2.645,00

FILTRATION OPTIONS	Filtering Surface	Filtration	PRICE
M Class Filter	20.000 cm ³	M	€ 112,00
M Class Filter + Antistatic	20.000 cm ³	M	€ 180,00
M Class Filter + PTFE	20.000 cm ³	M	€ 231,00

FILTRATION OPTIONS	Filtering Surface	Filtration	PRICE
Nomex filter High Temperature 200/220 C°	20.000 cm ³	M	€ 182,00
L Class Filter	30.000 cm ³	L	€ 95,00
M Class Filter	30.000 cm ³	M	€ 215,00

MANUAL CLEANING

POWERVAK Base BT 722

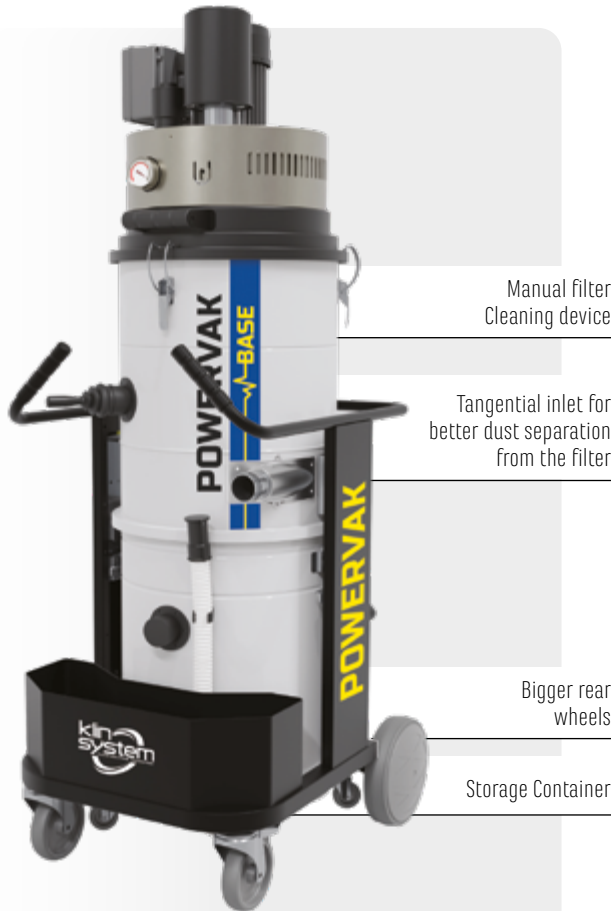

Manual filter
Cleaning device

Tangential inlet for
better dust separation
from the filter

Bigger rear
wheels

Storage Container

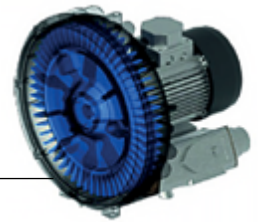

Side channel turbine
2.2 Kw / 3Kw



Filtration Class L / M
22.000 / 30.000 cm²



OPTIONAL
secondary HEPA filter
€ 220,00

POWERVAK BASE BT 722 - 730 are among the most popular turbine models on the market of industrial vacuum cleaners as they have excellent reliability thanks to the side channel turbine and have the ability to be multipurpose for the suction of any kind of debris, whether dusty, solid or liquid.



TANK QUICK RELEASE FOR FAST DISPOSAL

LONGOPAC® DUST COLLECTING SYSTEM

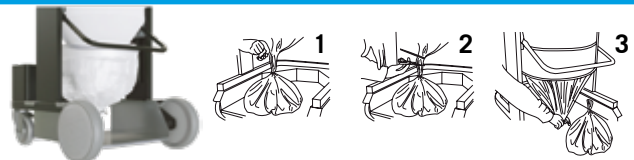

BASE BT 722 / BT 730 BAG models are equipped with a Longopac continuous bag system which allows the bagging of fine and dry dust, creating bags of variable size and weight, to be able to seal them and conveniently dispose them in absolute safety.

LONGOPAC BOX with 4 cartridge of 22meters

€ 195,00

FILTERING SYSTEM

Filter Type	Stellar polyester	Filter Media	L
Filter-Surface	22.000 cm²	Filter Cleaning	Manual shaking

	Motor	Power	Voltage/Freq	Amp	Airflow	Dep. Max	Capacity	Weight	Dimension (cm)	Ø Nozzle	PRICE
BT 722 BL	Turbine	2.2 Kw	230V/50 Hz	16 A	320 m ³ /h	200 mBar	100 Lt	92 Kg	85 x 65 x 199	Tangential Ø 60mm	€ 2.995,00
BT 730 BL	Turbine	3 Kw	400V/50-60Hz	6,7 A	320 m ³ /h	250 mBar	100 Lt	92 Kg	85 x 65 x 199	Tangential Ø 60mm	€ 2.855,00
BT 722 BL BAG	Turbine	2.2 Kw	230V/50 Hz	16 A	320 m ³ /h	200 mBar	Longopac	92 Kg	85 x 65 x 199	Tangential Ø 60mm	€ 3.635,00
BT 730 BL BAG	Turbine	3 Kw	400V/50-60Hz	6,7 A	320 m ³ /h	250 mBar	Longopac	92 Kg	85 x 65 x 199	Tangential Ø 60mm	€ 3.495,00

FILTRATION OPTIONS	Filtering Surface	Filtration	PRICE	FILTRATION OPTIONS	Filtering Surface	Filtration	PRICE
M Class Filter	20.000 cm ³	M	€ 112,00	Nomex filter High Temperature 200/220 C°	20.000 cm ³	M	€ 182,00
M Class Filter + Antistatic	20.000 cm ³	M	€ 180,00	L Class Filter	30.000 cm ³	L	€ 95,00
M Class Filter + PTFE	20.000 cm ³	M	€ 231,00	M Class Filter	30.000 cm ³	M	€ 215,00

POWERVAK Base BT 155

MANUAL CLEANING



Manual filter
Cleaning device

Tangential inlet for
better dust separation
from the filter

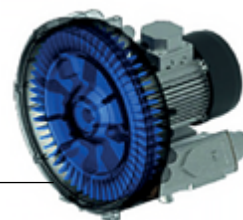

Double stage Side
channel turbine
5.5 Kw



Filtration Class L / M
20.000 / 30.000 cm²



OPTIONAL
secondary HEPA filter
€ 220,00

POWERVAK BASE BT 155 P / S is the industrial vacuum cleaner that combines power and reliability, motorized with 5,5 kW three-phase side channel turbine. Designed and built for constant and continuous use is critical for companies that need a good suction power for vacuuming non-specific dust or debris that can be fine dust.



TANK QUICK RELEASE FOR FAST DISPOSAL

The release system for the container allows for effortless emptying of the cleaner thanks to the detachment of the vacuum head.

LONGOPAC® DUST COLLECTING SYSTEM

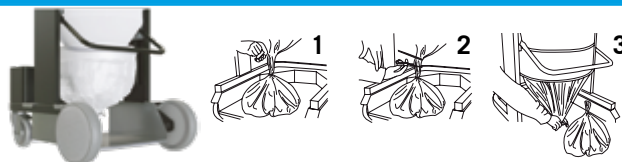

POWERVAK BASE BT 155 P/S BAG models are equipped with a Longopac continuous bag system which allows the bagging of fine and dry dust, creating bags of variable size and weight, to be able to seal them and conveniently dispose them in absolute safety.

LONGOPAC BOX with 4 cartridge of 22meters

€ 195,00

FILTERING SYSTEM

Filter Type	Stellar polyester	Filter Media	L
Filter-Surface	20.000 cm ²	Filter Cleaning	Manual shaking

	Motor	Power	Voltage/Freq	Amp	Airflow	Dep. Max	Capacity	Weight	Dimension (cm)	Ø Nozzle	PRICE
BT155 L-P	Turbine	5.5 Kw	400V/50 Hz	10,4 A	520 m ³ /h	320 mBar	100 Lt	150 Kg	100 x 60 x 140	Tangential Ø 60mm	€ 4.185,00
BT155 L-S	Turbine	5.5 Kw	400V/50-60Hz	10,4 A	320 m ³ /h	530 mBar	100 Lt	150 Kg	100 x 60 x 140	Tangential Ø 60mm	€ 4.185,00
BT155 L-P BAG	Turbine	5.5 Kw	400V/50 Hz	10,4 A	520 m ³ /h	320 mBar	Longopac	150 Kg	100 x 60 x 140	Tangential Ø 60mm	€ 4.820,00
BT155 L-S BAG	Turbine	5.5 Kw	400V/50-60Hz	10,4 A	320 m ³ /h	530 mBar	Longopac	150 Kg	100 x 60 x 140	Tangential Ø 60mm	€ 4.820,00

FILTRATION OPTIONS	Filtering Surface	Filtration	PRICE	FILTRATION OPTIONS	Filtering Surface	Filtration	PRICE
M Class Filter	20.000 cm ³	M	€ 112,00	Nomex filter High Temperature 200/220 C°	20.000 cm ³	M	€ 182,00
M Class Filter + Antistatic	20.000 cm ³	M	€ 180,00	L Class Filter	30.000 cm ³	L	€ 95,00
M Class Filter + PTFE	20.000 cm ³	M	€ 231,00	M Class Filter	30.000 cm ³	M	€ 215,00

MANUAL CLEANING

POWERVAK Base BT 255



Manual filter
Cleaning device

Tangential inlet for
better dust separation
from the filter

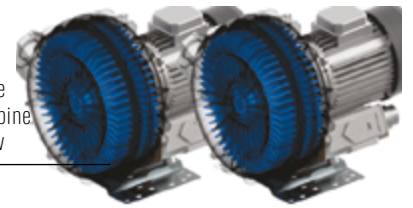

Two Double stage
Side channel turbine
2 x 5.5KW / 11 Kw



Filtration Class L / M
50.000 cm²



OPTIONAL
secondary HEPA filter
€ 986,00

POWERVAK BASE BT 255 is an extremely powerful industrial vacuum cleaners with double side channel turbine for a total of 11 kW, with manual shaking cleaning system. Can be used in heavy duty applications, or for centralised systems. Also, optional, with automatic Filter Cleaning System



TANK QUICK RELEASE FOR FAST DISPOSAL

The release system for the container allows for effortless emptying of the cleaner thanks to the detachment of the vacuum head.

LONGOPAC® DUST COLLECTING SYSTEM

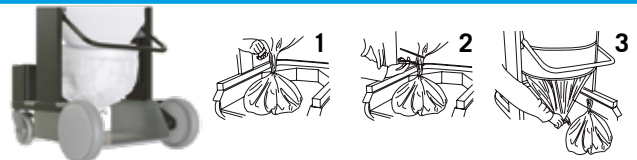

POWERVAK BASE BT 255 BAG models are equipped with a Longopac continuous bag system which allows the bagging of fine and dry dust, creating bags of variable size and weight, to be able to seal them and conveniently dispose them in absolute safety.

LONGOPAC BOX with 4 cartridge of 22meters

€ 195,00

TECHNICAL DATA BT 255 / BT 255 BAG

Motorization	2 x Turbine	Max Depression	320 mBar
Power	11 Kw	Ø Nozzle	Tangential Ø 90 mm
Voltage	400 V	Tank Diameter	Ø 560 mm
Frequency	50 Hz	Dimensions	150 x 78 x 174 cm
Amperage	21 A	Weight	150 Kg
Airflow	1040 m ³ /h	Capacity	Tank 160 Lt / Longopac

FILTERING SYSTEM

Filter Type	Stellar polyester	Filter Cleaning	Manual Shaking
Filter-Surface	50.000 cm ²	Price BT 111 P	€ 12.065,00
Filter Media	L	Price BT 111 P BAG	€ 12.855,00

FILTRATION OPTIONS

Filtration Options	Filtering Surface	Filtration	PRICE
M Class Filter	50.000 cm ²	M	€ 250,00
M Class Filter + Antistatic	50.000 cm ²	M	€ 285,00
M Class Filter + PTFE	50.000 cm ²	M	€ 369,00



ONE



THE VACUUM ONE models represent the best choice compared to the conventional self-service vacuums thanks to the superior engineering design thus offering advantages in terms of suction efficiency and ergonomical features for the machine management.

FILTERING SYSTEM

The filter is polyester made with conical shape. The accessibility to the filter is easy and free of containment vacuumed material thanks to the scroll guides placed on the top of the machine. The tangential inlet is on standard, in order to prevent long bodies from getting stuck at the vacuum inlet, increasing moreover the cyclone effect of debris.

SMART AND HEALTHY DEBRIS DISPOSAL SYSTEM

The quick tank release with wheels is useful to car-wash station's owner when the vacuum must be emptied, avoiding to take the cover and conventional filters out ensuring a dust-free and comfortable maintenance.

AUTOMATIC FILTER CLEANING

Once the credit is over the vacuum turn off and a weight inside the filter fall down shaking it.

OPTIONALS	DESCRIPTION	PRICE
KACSELF	Compressed air Kit	€ 255,00
7546SF	Blowing Kit	€ 690,00
COUNTER	Electromechanic counter	€ 60,00

MODEL	Motorization	Body	Voltage / Freq.	Filter	Filter Shaker	Air flow	Max dep.	Cap.	Coin acceptor	Size (cm)	PRICE
ONE 3 PH - Mec	Turbine 2,2 Kw	Stainless Steel Aisi 304	400V / 50Hz	Polyester 4.000cm ²	Automatic	320 m ³ /h	320 mBar	50 Lt	Mechanical	90x65x160	€ 3.725,00
ONE 3 PH - Ele	Turbine 2,2 Kw	Stainless Steel Aisi 304	400V / 50Hz	Polyester 4.000cm ²	Automatic	320 m ³ /h	320 mBar	50 Lt	Electronic	90x65x160	€ 4.015,00

Also available version Turbine 2,2 kW - 230 V (mechanical or electronic)

EVO



EVO INNOVATIVE SELF-SERVICE VACUUMS are designed following industrial vacuum's standards offering advantages in terms of suction efficiency and reduced filter clogging. The maintenance of filters is absolutely limited compared to the conventional self-service vacuums, thanks to the Klinsystem industrial vacuums filtration technology and filters cleaning allowing an almost free-maintenance to the vacuum. These great advantages bring benefits to the customer's satisfaction in terms of performances and consequently to the car wash station's owner limiting his contact with hazardous dusts, especially when the container must be emptied or a standard filter must be frequently cleaned.

FILTERING SYSTEM

The aluminized Class M cartridge filter is conductive, ensuring the discharge of static electricity and protected by a special Patented cyclone made of stainless steel. The tangential inlet is on standard, in order to prevent long bodies from getting stuck at the vacuum inlet, increasing moreover the cyclone effect of debris. The filter protection is made to reduce the filter clogging and to ensure that the filter remains Dry even if customers would like to collect few quantities of liquids.

SMART AND HEALTHY DEBRIS DISPOSAL SYSTEM

The quick tank release with wheels is useful to car-wash station's owner when the vacuum must be emptied, avoiding to take the cover and conventional filters out ensuring a dust-free and comfortable maintenance.

OPTIONALS	DESCRIPTION	PRICE
KACSELF	Compressed air Kit	€ 255,00
7546SF	Blowing Kit	€ 690,00
SAFE	Safe collection of maney or token with lock	€ 60,00
COUNTER	Electromechanic counter	€ 60,00

MODEL	Motorization	Body	Voltage / Freq.	Filter	Filter Shaker	Air flow	Max dep.	Cap.	Coin acceptor	Size (cm)	PRICE
EVO 3 PH - Mec	Turbine 2,2 Kw	Stainless Steel Aisi 304	400V / 50Hz	Cartridge 13.000cm ²	Manual	320 m ³ /h	320 mBar	50 Lt	Mechanical	90x65x160	€ 3.990,00
EVO 3 PH - Ele	Turbine 2,2 Kw	Stainless Steel Aisi 304	400V / 50Hz	Cartridge 13.000cm ²	Manual	320 m ³ /h	320 mBar	50 Lt	Electronic	90x65x160	€ 4.280,00

Also available version Turbine 2,2 kW - 230 V (mechanical or electronic)

MADE in ITALY



CAR WASH INDUSTRIAL VACUUMS

SHAKE



SHAKE INNOVATIVE SELF-SERVICE VACUUMS are designed following industrial vacuum's standards offering advantages in terms of suction efficiency and reduced filter clogging. The maintenance of filters is absolutely limited compared to the conventional self-service vacuums, thanks to the Klinsystem industrial vacuums filtration technology and filters cleaning allowing an almost free-maintenance to the vacuum. These great advantages bring benefits to the customer's satisfaction in terms of performances and consequently to the car wash station's owner limiting his contact with hazardous dusts, especially when the container must be emptied or a standard filter must be frequently cleaned.

FILTERING SYSTEM

The aluminized Class M cartridge filter is conductive, ensuring the discharge of static electricity and protected by a special Patented cyclone made of stainless steel. The tangential inlet is on standard, in order to prevent long bodies from getting stuck at the vacuum inlet, increasing moreover the cyclone effect of debris. The filter protection is made to reduce the filter clogging and to ensure that the filter remains Dry even if customers would like to collect few quantities of liquids.

PATENTED SEMI-AUTOMATIC FILTER SHAKER

The filter shaker is formed by a mechanical-pneumatic piston, which, by moving up and down, violently hits the bottom of the filter thus creating the vibrations required for perfect cleaning and also reducing operation time. This function is performed automatically by moving a lever on the machine.

SMART AND HEALTHY DEBRIS DISPOSAL SYSTEM







The quick tank release with wheels is useful to car-wash station's owner when the vacuum must be emptied, avoiding to take the cover and conventional filters out ensuring a dust-free and comfortable maintenance.

OPTIONALS	DESCRIPTION	PRICE
KACSELF	Compressed air Kit	€ 255,00
7546SF	Blowing Kit	€ 690,00
SAFE	Safe collection of maney or token with lock	€ 60,00
COUNTER	Electromechanic counter	€ 60,00





MODEL	Motorization	Body	Voltage / Freq.	Filter	Filter Shaker	Air flow	Max dep.	Cap.	Coin acceptor	Size (cm)	PRICE
SHAKE 3 PH-Mec	Turbine 2,2 Kw	Stainless Steel Aisi 304	400V / 50Hz	Cartrige 13.000cm ²	Semi-Auto	320 m ³ /h	320 mBar	50 Lt	Mechanical	90x65x160	€ 4.715,00
SHAKE 3 PH-Ele	Turbine 2,2 Kw	Stainless Steel Aisi 304	400V / 50Hz	Cartrige 13.000cm ²	Semi-Auto	320 m ³ /h	320 mBar	50 Lt	Electronic	90x65x160	€ 5.005,00

Also available version Turbine 2,2 kW - 230 V (mechanical or electronic)

KIT ACCESSORIES

	CODE	Kit for general cleaning on models which can fit the 60-50 intel connection		Ø 50 mm	PRICE
	KIT10M.50	60 - 50	Accessory vacuum inlet connection for Ø 50 hoses		€ 440,00
		TEVO5001	Flex Hose Eva 10 meters		
		DCCR50XX	Steel chromed handgrip Ø 50		
		SPXO420D	Dust stainless steel floor brush Width 420 mm		
PM50PA	Accessory vacuum inlet connection				
	CODE	Kit for general cleaning on models which can fit the 60-50 intel connection		Ø 50 mm	PRICE
	KIT5M.50	60 - 50	Accessory vacuum inlet connection for Ø 50 hoses		€ 370,00
		TEVO505C	Flex Hose Eva 5 meters		
		DCCR50XX	Steel chromed handgrip Ø 50		
		SPXO420D	Dust stainless steel floor brush Width 420 mm		
PM50PA	Accessory vacuum inlet connection				
	CODE	Kit for general cleaning on models which can fit the 60-50 intel connection		Ø 50 mm	PRICE
	KIT3M.50	60 - 50	Accessory vacuum inlet connection for Ø 50 hoses		€ 330,00
		TEVO5001	Flex Hose Eva 3 meters		
		DCCR50XX	Steel chromed handgrip Ø 50		
		SPXO420D	Dust stainless steel floor brush Width 420 mm		
PM50PA	Accessory vacuum inlet connection				
	CODE	Accessories for general cleaning on models which can fit the 60-50 intel connection		Ø 38 mm	PRICE
	KIT5M.38	60 - 38PP	Accessory vacuum inlet connection for Ø 38 hoses		€ 165,00
		TEVO385C	Flex Hose Eva 5 meters Ø 38 complete with plastic hose cuffs		
		DCCR38PP	Steel chromed handgrip Ø 38		
SPPX400	Plastic liquids or dust floor brush Width 400 mm				
	CODE	Kit for models provided with 60-38 PP vacuum intel connection Provided with plastic handgrip with aluminum core		Ø 38 mm	PRICE
	K38.D0002 K38.W0001	TEVO383C.1	Flex Hose Eva 3 meters Ø 38 complete with plastic hose cuffs		€ 125,00
		DCPL38	Ø 38 Plastic handgrip with aluminum care		
		SPPP400D	Plastic dust floor brush Width 400 mm		
		SPPP400W	Plastic liquids floor brush Width 400 mm		
		LP38PL	Plastic Ø 38 crevice nozzle		
PEP38	Plastic round brush Ø 38 mm				
	CODE	Kit for models provided with 60-38 PP vacuum intel connection With steel handgrip and stainless steel floor brush		Ø 38 mm	PRICE
	K38.D0003 K38.W0004	TEVO383C.1	Flex Hose Eva 3 meters Ø 38 hose cuffs		€ 260,00
		DCCR38XX	Steel chromed handgrip Ø 38		
		SPXO420D	Dust stainless steel floor brush Width 420 mm		
		SPXO420W	Liquids stainless steel floor brush Width 420 mm		
		LP38PL	Plastic Ø 38 crevice nozzle		
PEP38	Plastic round brush Ø 38 mm				

KIT ACCESSORIES

	CODE	Kit for general cleaning for models provided with 60-50 vacuum intel connection	Ø 38 mm	PRICE
	K38.D0003 K38.W0004	60 - 50	Accessory vacuum inlet connection for Ø 50 hoses	€ 305,00
	TEVO383C.2	Flex Hose Eva 3 meters with Ø 38 hose cuffs		
	DCCR38XX	Steel chromed handgrip Ø 38		
	SPXO420D	Dust stainless steel floor brush Width 420 mm		
	SPXO420W	Liquids stainless steel floor brush Width 420 mm		
	LP38PL	Plastic Ø 38 crevice nozzle		
	PEP38	Plastic round brush Ø 38 mm		
	CODE	Kit for fine and dry dust suction and ATEX models Available on models which can fit the 60-50 intel connection	Ø 38 mm	PRICE
	K38.DC006	60 - 50	Accessory vacuum inlet connection for Ø 50 hoses	€ 430,00
	TEVO383C	Flex Hose Conductive Eva 3 meters with Ø 38 hose cuffs		
	DCCR38XX	Steel chromed handgrip Ø 38		
	SPXO420D	Dust stainless steel floor brush Width 420 mm		
	PLG44A	Rubber crevice nozzle Ø 38-50		
	PRB80-NY38	Conduction rubber round brush with zinc-plated Ø 38 reductor		
	PT 38 A	Ø 38 rubber cone with zinc-plated reductor		
	CODE	Kit for fine and dry dust suction and ATEX models Available on models where is possible connect the 60-50 intel connection	Ø 50 mm	PRICE
	K50.DC008	60 - 50	Accessory vacuum inlet connection for Ø 50 hoses	€ 510,00
	TEVC503C	Flex Hose Conductive Eva 3 meters with Ø 38 hose cuffs		
	50-50 EST	Ø 50 Quick fit aluminum accessory connection		
	DCCR50XX	Steel chromed Handgrip Ø 38		
	SPXO420D	Dust stainless steel floor brush Width 420 mm		
	PLG44A	Rubber crevice nozzle Ø 38-50		
	PRB80-NY50	Conductive rubber round brush		
	PT 50 A	Ø 50 rubber cone with zinc-plated reductor		
	CODE	Kit ovens suction Available on models which can fit the 60-50 intel connection	Ø 50 mm	PRICE
	K50.W0010	TACC503C	Steel Hose Ø 50 complete with aluminum connections	€ 515,00
	PRAL2050	Aluminum extension Ø 50 - 2 meters		
	SPXO420F	Ovens stainless steel floor brush Width 420 mm		
	PL50AC	Steel chromed crevice nozzle		
	CODE	Kit for mechanical workshops Available on models which can fit the 60-50 intel connection	Ø 50 mm	PRICE
	K50.W0010	TPUH503C	Anti-abrasive SuperFlex Hose 3 meters Ø 50 complete with aluminum connections	€ 560,00
	DCCR50XX	Steel chromed handgrip Ø 50		
	SPXO420O	Liquids stainless steel floor brush with OIL-proof rubbers Width 420 mm		
	PT 50 A	Ø 50 rubber cone with zinc-plated reductor		
	PC 50 A	Bent nozzle 90° angle		
	PV 120 A	Rubber hand scraping tool Ø 50		

Index

- ▶ Floor Grinding and Polishing Machines pag. 4
- ▶ Diamond Tools and Diamond Floor Pads pag. 20
- ▶ Trowel Shine pag. 36
- ▶ Klinsystem Floor Grinders pag. 38
- ▶ Speedy 3 Step and 4 Step Polishing System..... pag. 42
- ▶ Polish Concrete System pag. 50
- ▶ Marble Polishing System pag. 63
- ▶ Special tools, Bush Hammer, Grinding Cup and Floor Pads pag. 67
- ▶ Granite Polishing System pag. 68
- ▶ Terrazzo Polishing System..... pag. 70
- ▶ Helix and Hypershine Diamond Floor Pads pag. 72
- ▶ Sand Paper, diamond brushes and accessories pag. 76
- ▶ Levitek 500 and Levitek 450 pag. 78
- ▶ Orbital Machines pag. 86
- ▶ Single Disc Machines pag. 94
- ▶ Professional Vacuum Cleaners pag. 98
- ▶ Industrial Vacuum Cleaners BOOST pag. 102
- ▶ Industrial Vacuum Cleaners ASC pag. 106
- ▶ Industrial Vacuum Cleaners BASE pag. 120
- ▶ Car Wash pag. 128
- ▶ Kit Accessories for Industrial Vacuums pag. 130



INTERNATIONAL DIAMOND CODE								
24	36	60	120	220	400	800	1500	3500

CONDIZIONI GENERALI DI VENDITA

Le presenti condizioni di vendita, salvo patto contrario espressamente pattuito nella conferma d'ordine, si intendono far parte integrale di qualsiasi rapporto contrattuale di fornitura avente per oggetto i prodotti della ditta. I prezzi, le caratteristiche tecniche e le condizioni di vendita riportate nel seguente catalogo/ listino non sono impegnative: la Ditta si riserva il diritto di modificarli in qualsiasi momento senza obbligo di preavviso. Tutte le forniture si intendono accettate ai prezzi indicati nel listino ufficiale in vigore al momento della consegna anche se la merce è consegnata in ritardo rispetto alla data prevista. Prezzi, sconti e condizioni delle singole forniture non sono impegnative per ordinazioni successive. Gli ordini raccolti tramite agenti, rappresentanti o incaricati dall'Azienda sono sempre subordinati all'insindacabile giudizio della Casa Venditrice e pertanto debbono considerarsi impegnativi solo a seguito della Conferma d'Ordine.

1) RESA: franco partenza sede di Turrialignani con spedizione in: a) Porto Franco con addebito in fattura se il trasporto viene effettuato tramite corrieri con noi convenzionati. b) Porto Assegnato qualora venga richiesto dal Cliente il trasporto mezzo corrieri con noi convenzionati. c) Per eventuali richieste di spedizioni con caratteristiche diverse dalle abituali (esempio: espresso, pacco aereo, spedizioni di merce il cui valore non raggiunge il Minimo d'Ordine stabilito dall'Azienda, ecc.) il costo verrà addebitato secondo tariffe da noi stabilite. Non si effettuano pacchi postali. **2) ORDINI:** vengono evasi secondo le disponibilità di magazzino, senza garanzia di saldo. **3) TRASPORTO:** fatto esclusione per il materiale consegnato dal nostro personale, le merci (anche se vendute Porto Franco) viaggiano sempre a rischio del Cliente che quindi solleva la Klinsystem da ogni responsabilità per eventuali danni subiti durante i trasporti. Per ogni ammanco, ritardo, disagio o reclamo bisogna rivolgersi al Vettore incaricato del trasporto. Si raccomanda di controllare i pesi e il numero dei colli al momento della consegna delle merci. 4) Eventuali lamentele per difetti saranno prese in considerazione solo entro 8 giorni dal ricevimento della merce. **5) PAGAMENTI:** dovranno essere effettuati nei termini concordati esclusivamente alla nostra Sede o a persone da noi espressamente autorizzate per iscritto. Non sono ammesse trattative ed arrotondamenti. Per i ritardi di pagamenti saranno conteggiati interessi di mora previsti dalla Legge. **6) RESI DI MERCE** per errori di ordinazione o per motivi non imputabili alla Klinsystem, saranno accettati solo se preventivamente autorizzati e se saranno spediti in porto franco. La merce relativa, se sarà riscontrato in perfetto stato, sarà accreditata nel valore fatturato meno il 15 % quale concorso spese riguardanti operazioni di controllo, magazzino e amministrativo. **7) IVA, TASSE E OGNI ALTRO ONERE FISCALE** sono a carico del committente. **8) CONDIZIONI DI GARANZIA:** le condizioni di garanzia sono espressamente indicate nel CERTIFICATO DI GARANZIA che accompagnano le nostre macchine. I materiali sono garantiti per qualità e lavorazione per la durata di un anno o per un massimo 600 ore (quello che scade prima). Ciò comporta, a insindacabile giudizio della Klinsystem, la loro sostituzione, la riparazione o l'accredito a condizioni che: a) il reso ci pervenga in Porto Franco, altrimenti verrà respinto. b) le parti in garanzia, dovranno essere consegnate con un DDT avente come causale "Conto in riparazione in garanzia" o in caso di consegne cumulative, la garanzia, dovrà essere evidenziata nel campo note del DDT. La Klinsystem srl non risponderà in nessun caso per eventuali nuovi addebiti per riparazioni in garanzia non evidenziate sui documenti di trasporto. La garanzia copre sia i costi del materiale (esclusi quelli di consumo e componenti elettrici) che quelli della manodopera. Tutte le riparazioni eseguite vengono sempre memorizzate nel nostro archivio storico che in caso di contestazioni è a disposizione per eventuali consultazioni. c) i materiali presentino evidenti difetti di costruzione e di qualità che dovranno essere indicati sul Documento che accompagna il reso. Sulla stessa è anche indispensabile indicare il riferimento della fattura di acquisto. d) Non saranno sostituiti, né riparati gratuitamente, i prodotti che risultassero guastati per imperizia, manomissione, per adattamento ad uso diversi da quelli ai quali sono destinati o per utilizzo di " utensili non originali" e) La Garanzia esclude qualsiasi danno o spese di ogni genere incluso mancato guadagno o risarcimento per lavori non ultimati in seguito a eventuale rottura della macchina. **9) MODALITA' DI RIPARAZIONE:** La Klinsystem garantisce che le riparazioni saranno effettuate a regola d'arte e l'utilizzo di componenti originali o equivalenti. Il cliente è tenuto a segnalare sul macchinario guasto l'inconveniente lamentato. Nulla potrà essere imputato alla Klinsystem, qualora in mancanza della segnalazione del guasto, non riuscisse ad identificare l'esatta provenienza dell'inconveniente. In assenza di segnalazione la Klinsystem offrirà garanzia esclusivamente sul difetto riscontrato e riparato dai propri tecnici. La Klinsystem qualora non riuscisse per qualsiasi motivo a riparare la parte ricevuta, restituirà la stessa senza nessun addebito. 9a) MANCATO RISCOSTRO DIFETTO: Qualora il macchinario da riparare non presentasse l'inconveniente descritto, trascorse ore 8 di collaudo, saranno applicati gli importi riportati nel listino in vigore. Se il difetto venisse nuovamente riscontrato entro 30 giorni successivi al collaudo e quindi presso la nostra sede, tale somma verrà scontata dal prezzo di riparazione. 9b) HOT LINE: per qualsiasi informazione tecnica i nostri uffici sono sempre a vostra disposizione tutti i giorni lavorativi nelle fasce orarie 8:00-18:00. 9c) SCONTO: in funzione di particolari accordi commerciali, potrà essere accordato uno sconto sui prezzi di listino. 9d) PAGAMENTI: I primi rapporti, e tutti quelli sino ad € 300,00 saranno regolati esclusivamente per contanti. 9e) LISTINO: La Klinsystem si riserva la facoltà di variare il proprio listino comunicandone la variazione, in tempo utile, prima della riparazione. 9f) RESPONSABILITA': La Klinsystem non si assume nessuna altra responsabilità od obbligazione nei confronti del Cliente o di terzi oltre a quelle espressamente elencate nelle presenti condizioni generali comprese quelle dall'uso delle parti riparate salvo i limiti indroverabili di legge. 9g) FACOLTA' DI RECESSO, MODIFICA O INTERRUZIONE DEL SERVIZIO: la Klinsystem si riserva la facoltà di interruzione o modificare l'erogazione del servizio fornendo un ragionevole preavviso al cliente. 9h) DIRITTO DI RITENZIONE: fermo restando il diritto di ritenzione ai sensi e per gli effetti dell'art. 2756 c.c., il mancato ritiro della merce entro 8 giori dalla comunicazione di compiuto lavoro, effettuata con lettera racc. A.R. al cliente senza riscontro da parte del medesimo, farà presumere la rinuncia ai beni con diritto dalla Klinsystem di disfarsene, salvo il diritto di richiedere quanto di sua spettanza. **10) FORO COMPETENTE:** Per qualsiasi controversia sarà competente esclusivamente il Tribunale di Pescara (PE) o il Giudice di pace di Pescara (PE). - LEGGE 675/96. **11) PRIVACY:** si informa che i dati personali verranno trattati per finalità commerciali. Di vendita diretta, promozionali, gestionali, statistiche di tutela del credito. Inoltre, il Cliente ha sempre diritti di ottenere la cancellazione scritta a mezzo racc. A.R. **12) GARANZIA:** Le condizioni di garanzia sono espressamente indicate nel relativo Certificato di garanzia che accompagna i nostri prodotti e le nostre macchine. I materiali sono garantiti per qualità e lavorazione per la durata di un anno o per avvenuto raggiungimento di 600 ore lavorative. Ciò comporta, a insindacabile giudizio della Klinsystem, la loro sostituzione, la riparazione o l'accredito a condizioni che: a) il reso pervenga in Porto Franco, altrimenti verrà respinto; b) le parti in garanzia, dovranno essere consegnate con un DDT avente come causale "Conto riparazione in garanzia"; in caso di consegne cumulative, la garanzia, dovrà essere evidenziata nel campo note del DDT. La Klinsystem non risponderà in nessun caso per eventuali nuovi addebiti di riparazioni in garanzia non evidenziate sui documenti di trasporto. La garanzia copre sia i costi del materiale (esclusi quelli di consumo) che quelli della manodopera. Tutte le riparazioni eseguite vengono sempre memorizzate nel nostro archivio storico che in caso di contestazioni è a disposizione per eventuali consultazioni; c) i materiali presentino evidenti difetti di costruzione e di qualità che dovranno essere sempre indicati sul documento che accompagna il reso. Inoltre, deve essere indicato il riferimento della fattura di acquisto; d) non saranno sostituiti, né riparati gratuitamente, i prodotti che risultassero guastati per imperizia, imprudenza, negligenza, manomissione, per adattamento ad usi diversi da quelli ai quali sono originariamente destinati o per utilizzo di " utensili non originali"; e) la Garanzia esclude qualsiasi danno o spese di ogni genere incluso mancato guadagno o risarcimento per lavori non ultimati in seguito ad eventuale rottura della macchina. **13) LEGGE APPLICABILE E FORO COMPETENTE:** Per qualsiasi controversia la legge applicabile è quella italiana. Foro competente in via esclusiva per ogni controversia tra la Klinsystem ed il Cliente è quello di Pescara (Italia). Questa macchina è garantita da difetti di costruzione per il periodo di anni 1 dalla data di acquisto se usata e mantenuta secondo le istruzioni riportate nel LIBRETTO DI ISTRUZIONI e MANUTENZIONI. La Garanzia è estesa solo alle parti originali previsti per l'uso del prodotto. La Garanzia decade se il difetto è dovuto a: imperizia, imprudenza, negligenza, manomissione, utilizzo per scopi diversi da quelli indicati nel Libretto di Istruzioni o per utilizzo di " utensili non originali" non approvati dal produttore. La Garanzia decade se la macchina risultasse manomessa da interventi di riparazione già effettuata senza autorizzazione. Non sono coperti da garanzia le normali parti di consumo quali: cavi elettrici, parti in gomma, tubi, spazzole, parti elettriche ed elettroniche. Qualsiasi difficoltà dovesse svilupparsi durante l'uso della macchina bisogna: 1) Contattare il SERVIZIO ASSISTENZA KLINSYSTEM 65020 TURRIALIGNANI Via Pescarina 154/A (Italia) Tel +39 3474678309 - info@klinsystem.com 2) Ritornare la macchina in Porto Franco. Le spese sono a carico del Cliente. Non saranno effettuati riparazioni in Garanzia se il Certificato di Garanzia non viene allegato alla macchina da riparare. 3) Klinsystem riparerà la macchina e /o sostituirà i pezzi difettosi senza nessun addebito in un tempo ragionevole dopo aver ricevuto la macchina. 4) la RESPONSABILITA' del produttore è limitata solo alla riparazione del prodotto e alla sostituzione dei ricambi ritenuti difettosi. In caso di malfunzionamento o difetto il produttore non potrà essere ritenuto responsabile per eventuali lavori non ultimati né di mancato guadagno. Al produttore non potrà essere richiesta nessuna penale di nessun tipo né altre forme di risarcimento di qualsiasi genere. La Garanzia esclude qualsiasi danno o spese di ogni genere incluso mancato guadagno o risarcimento per lavori non ultimati in seguito ad eventuale rottura della macchina. Non ci sono altre garanzie oltre quelle qui specificate. Non ci sono altre forme di garanzia che si estendono oltre quelle qui descritte, né altre forme di garanzie promesse dai rivenditori. **LIMITI DI RESPONSABILITÀ** Nessuna garanzia è fornita per gli utensili e/o per i materiali di consumo. L'operatore deve accertarsi prima dell'uso che l'utensile da lui scelto sia adatto all'uso. Nessuna responsabilità potrà essere attribuita alla Klinsystem per l'utilizzo degli utensili. Le informazioni di questo Catalogo sono fornite in buona fede e Klinsystem le ritiene accurate. In ogni caso, chiunque intenda acquistare prodotti non deve rifarsi a dette informazioni ma deve accertarsi, ulteriormente, dell'effettiva natura dei prodotti e della loro concreta idoneità all'uso che se ne intende fare. Conseguentemente, tutte le informazioni di questo Catalogo sono fornite senza alcuna garanzia, implicita od esplicita, di qualsiasi tipo, quali, a titolo puramente esemplificativo, di qualità dei prodotti, di idoneità per uno specifico scopo o di non violazione di diritti di proprietà intellettuale. In nessun caso Klinsystem sarà ritenuta responsabile per qualsiasi danno diretto o indiretto, causato dall'utilizzo di questo catalogo. Le informazioni contenute in questo catalogo possono essere tecnicamente inaccurate o viziate da errori tipografici. Le informazioni possono essere modificate od aggiornate senza preavviso. Klinsystem può anche migliorare o cambiare alcuni prodotti descritti in questo Catalogo, senza preavviso.

FLOOR SOLUTION TECHNOLOGY



Office +39 085 7880800

Mobile +39 347 4678309



www.klinsystem.com



info@klinsystem.com



Via degli Alpini snc
65029 Torre De Passeri
(Pescara) - ITALY

YOUR LOCAL DISTRIBUTOR: